

Item	Part #	Description
1.	1117972	Fiberglass Ridgepole Connector
2.	1704098	Spring Pin - 1/4" x 1 1/4"
3.	1703594	Fiberglass Ridgepole - 7/8" x 20'

STEP 1: Insert first fiberglass ridgepole section halfway into ridgepole connector. Use hole in connector as a guide to drill 1/4" hole through ridgepole section.

STEP 2: Install spring pin through hole to secure ridgepole section to connector.

STEP 3: Insert second fiberglass ridgepole section into opposite end of connector, butting end of second ridgepole against first ridgepole. Use hole in connector as a guide to drill 1/4" hole through ridgepole section.

STEP 4: Install spring pin through second hole to secure ridgepole section to connector.

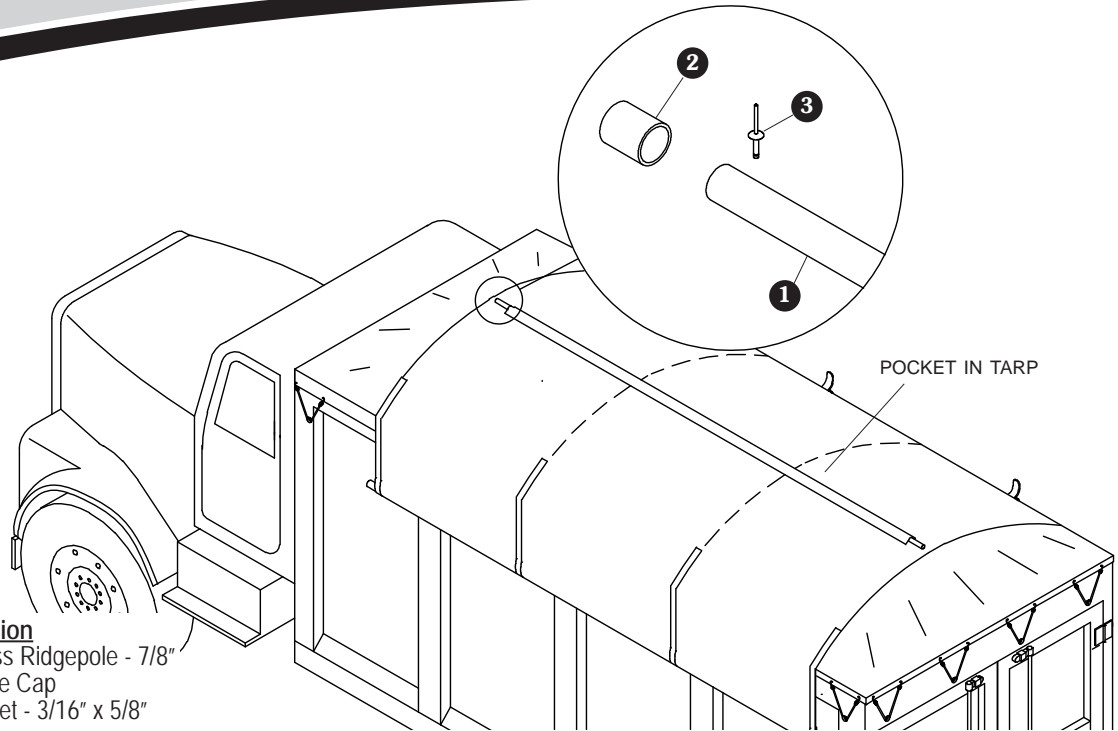

Item	Part #	Description
1.		Fiberglass Ridgepole - 7/8"
2.	1703207	Protective Cap
3.	1705224	Blind Rivet - 3/16" x 5/8"

STEP 1: Cut ridgepole tube 2" shorter than tarp length. Grind rough edges smooth. Wrap ridgepole with tape for smoother cut.

STEP 2: Install rubber sleeves over ends of ridgepole.

STEP 3: Insert ridgepole into ridgepole tarp pocket. Center pole in tarp pocket and verify that ridgepole is 1" shorter than tarp on each end. Drill 3/16" hole through ridgepole pocket and fiberglass rod as shown.

⚠ CAUTION

Do not puncture tarp. Install rivet through top of tarp pocket and into ridgepole. Place barrier between ridgepole and tarp to prevent puncturing tarp.

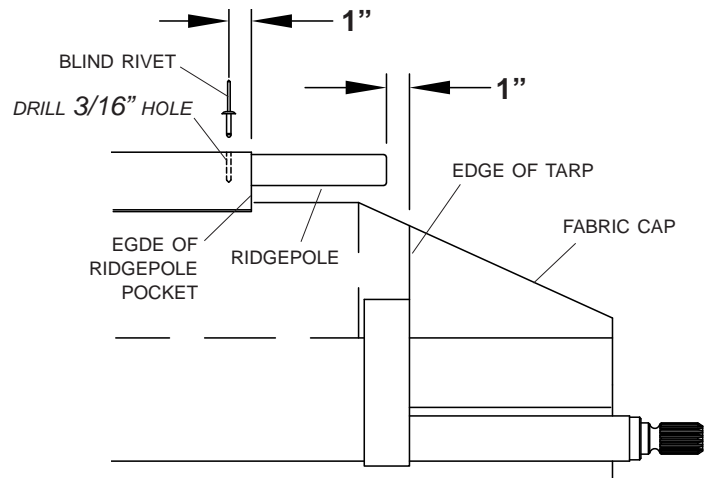
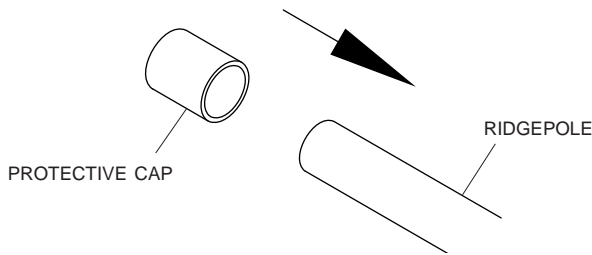

STEP 4: Install rivet 1" from edge of pocket. Pull tarp to full length and install second rivet 1" from opposite end of pole.