



ENGINEERED TARPING SOLUTIONS



The Original **SHUR-LOK[®]** for **END DUMPS**

Dependable watertight protection for whatever you're hauling!

VALUE SERIES or SUPER DUTY SHUR-LOK[®]

- Aluminum Latchplate
- Rear Fabric Cap/Flap
- Easy-Off Front Fabric Cap
- Easy-Off Tarp Stops
- Shur-Flex[™] Crank Arm
- Front Roll Return
- Crank Retainers
- 22-Oz. Vinyl-Coated Tarp

Our base-model Shur-Lok[®] will do the job for you – and do it well, but if you like to customize, we have plenty of options and upgrades. If you have additional requirements, we are willing and able to custom manufacture to meet your exact specifications.*

For more information, give us a call. Customer service representatives are standing by to help with any questions you may have.

**Additional costs may apply.*

The Shur-Flex[™] crank arm offers convenient flexibility. It folds at the knuckle and secures with offset or pinless offset retainers – no more pin-and-cable hassles. It can be customized to fit your trailer.



The easy-off front fabric cap makes it easier to come over the top of the doghouse. Double bows secure into a double bow bracket – exactly the right spacing for tightening down the front of the tarp.



The front stretch roll return guides the roll tube over the cap end, and its protective cover keeps the rope from fraying on the latchplate. Or upgrade to our exclusive Shur-Return[®] with heavy-duty steel tension spring and lifetime warranty.



Reinforced stitching along the radius corner of the front fabric cap increases tear strength and helps the tarp withstand the stresses of traveling at highway speeds.



BOX DETAIL SHEET ON REVERSE SIDE.

1-800-474-8756

www.shurco.com

BOX DETAIL SHEET *for* END DUMPS

CONTACT INFORMATION

NAME _____
 ADDRESS _____
 CITY _____ STATE _____ ZIP _____
 PHONE _____ FAX _____
 BOX/TRAILER MAKE _____

OUTSIDE DIMENSIONS

A _____ UPPER BOX LENGTH
 U _____ INSIDE BOX WIDTH
 B _____ UPPER BOX WIDTH
 Front _____ Center _____ Rear _____
 N _____ TOP RAIL WIDTH
 X _____ BOX HEIGHT

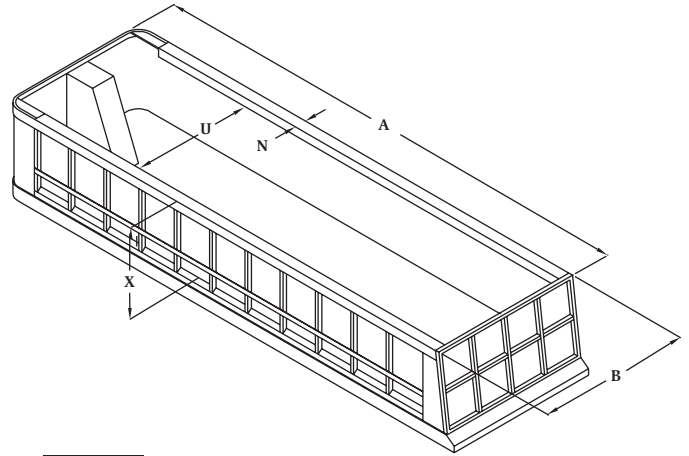

CORNER CONFIGURATION (See Figure 1.) **MUST SELECT ONE.**

- SQUARE DIAGONAL RADIUS/NO RECESS
 SQUARE RECESS DIAGONAL RECESS
- C _____ OUTSIDE CORNER RADIUS (Needed on all radius fronts.)
 D _____ RECESSED WIDTH
 E _____ FLAT ACROSS FRONT
 F _____ FRONT TO CORNER POST
 G _____ GUSSET LENGTH
 V _____ FLAT ACROSS DIAGONAL
 W _____ DIAGONAL DEPTH

TOP RAIL STYLE (See Figure 2.)

- SQUARE SELF CLEANING SQUARE W/PLANKS*
 *Are planks flush with outside of top rail? Y / N (Circle one.)

TOP RAIL DROP (See Figure 3.)

- FRONT REAR
- L _____ BULKHEAD DEPTH O1 _____ FRONT TOP RAIL DROP
 M _____ THRESHOLD DEPTH O2 _____ REAR TOP RAIL DROP

FRONT END STYLE (See Figure 4.)

- RAISED FRONT SHIELD RAISED SHIELD & FLAT TOP RAIL
 SLANT w/CURVED RAISED FRONT SLANT w/SQUARE RAISED FRONT
 SQUARE TUB w/INVERTED RAM
- AD _____ CYLINDER HEIGHT J _____ UPPER SHIELD WIDTH
 AE _____ DOGHOUSE DEPTH J1 _____ DOGHOUSE WIDTH
 H _____ SHIELD HEIGHT K _____ LOWER SHIELD WIDTH

REAR DUMP STYLE (See Figure 5.)

- OVERSLUNG HINGE GATE COMBO DOOR HINGE GATE
 HIGH POWER LIFT GATE RAISED HINGE GATE
- AF _____ HINGE DEPTH
 AK _____ HINGE HEIGHT
 B _____ BOX WIDTH/REAR

TARP WEIGHT and COLOR(S)

22 OZ. _____

Figure 1

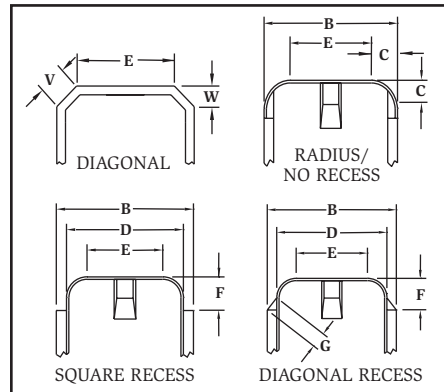

Figure 2

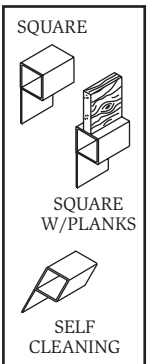

Figure 3

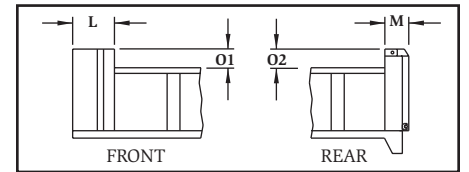

Figure 4

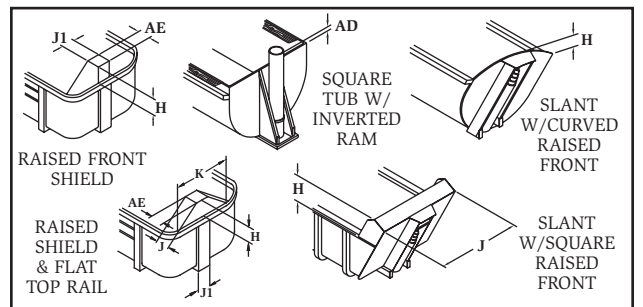
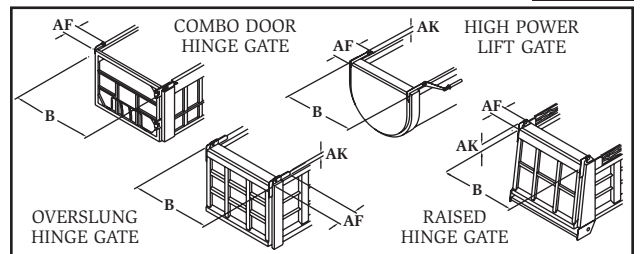

Figure 5



FAX 1-605-665-0501

Salesperson _____