

**Standard Crank Retainers**

Item	Part No.	Part Name
	1100386	Crank Retainer Kit w/7" Standoff
	1100388	Crank Retainer Kit w/2" Standoff
	1107047	Pinless Crank Retainer Kit w/7" Standoff
1.	1700407	Hex Nut - 3/8"
2.	1700434	Lock Washer - 3/8"
3.	1100574	Cable w/#5 Interlock Snap
4.	1700526	Wire Lock Pin - 3/8" x 2 1/2"
5.	1700400	Self-Tapping Screw - 3/8" x 1"
6.	1100306	Retainer Bushing - 11/16"
7.	1100040	J-Hook Crank Retainer
8.	1107049	Pinless Crank Retainer
9.	1702996	Hex Flange Cap Screw - 1/2" x 1 1/4"
10.	1100137	Crank Retainer Standoff - 2"
	1107080	Crank Retainer Standoff - 3"
	1100033	Crank Retainer Standoff - 7"
	1109478	Crank Retainer Standoff - 11"

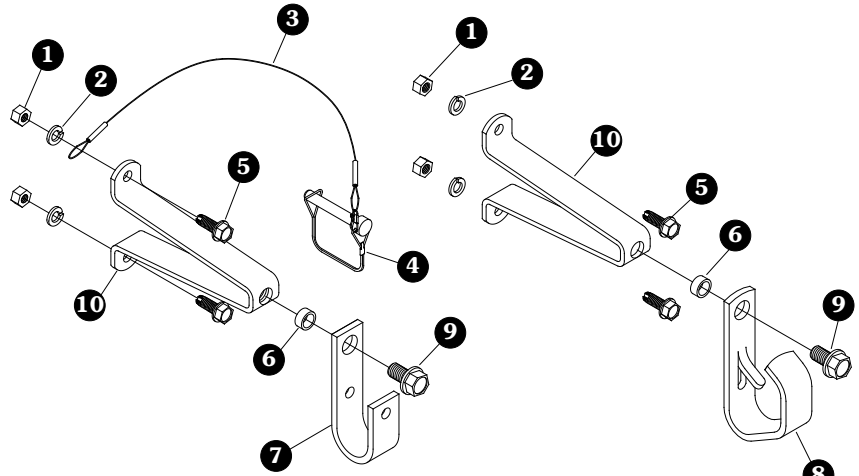

**J-Hook Crank Retainer**

**Pinless Crank Retainer**

**STEP 1:** Assemble crank retainers.

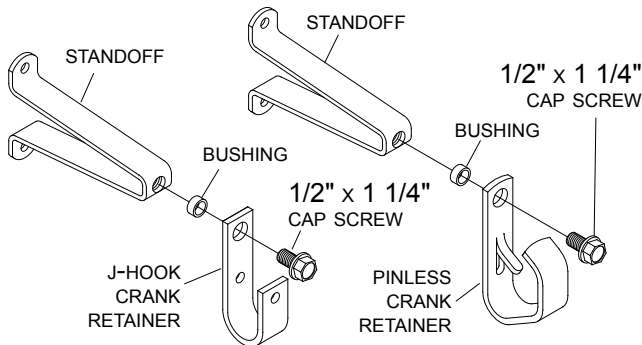

**STEP 2:** With tarp closed, rotate crank arm across rear of box to determine crank retainer location. Position crank retainer to hold crank arm securely in place.

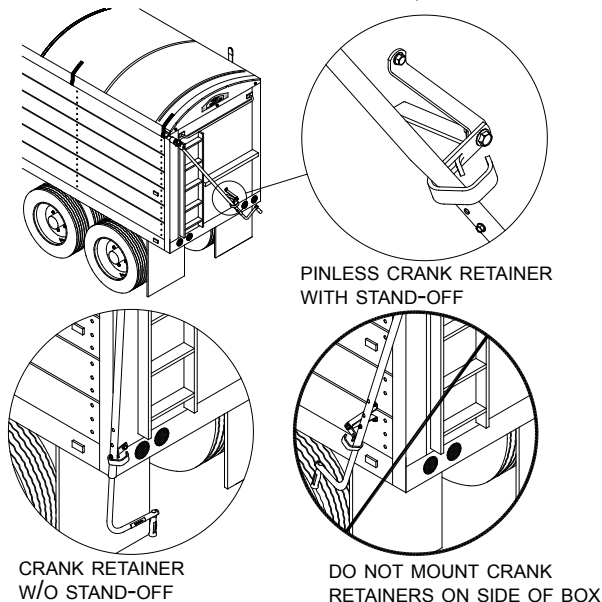

**STEP 3:** Using standoff as a guide, mark and drill 13/32" holes in trailer (see note). Fasten crank retainer to box with 3/8" x 1" cap screws, lock washers, flat washers and nuts. Fasten cable w/snap and wire lock pin between stand-off and box.

**NOTE:** Drill 5/16" holes if washers and nuts cannot be used, and trailer wall is at least 3/16" thick.

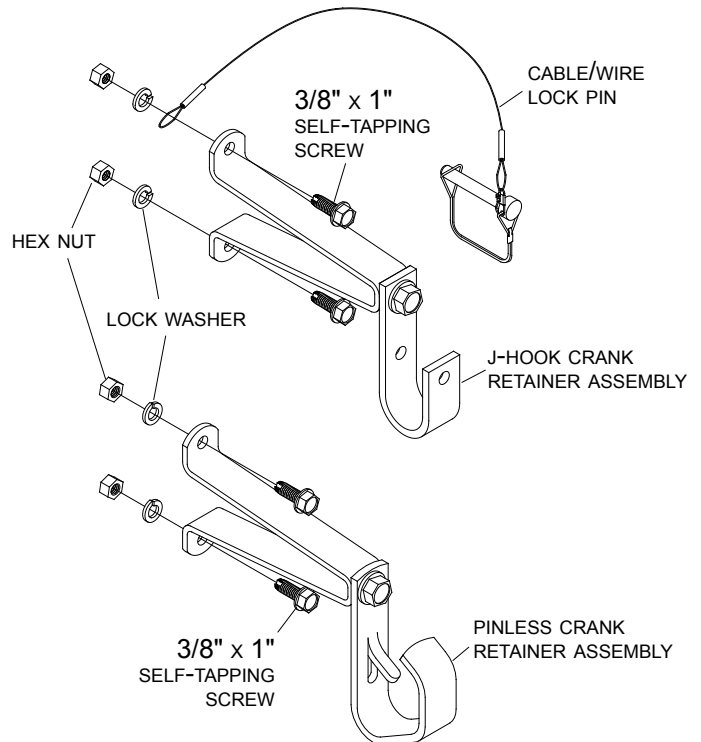

**Stainless Steel Crank Retainers**

Item	Part No.	Part Name
	1119443	Stainless Steel Crank Retainer Kit w/7" Standoff
	1115515	Stainless Steel Pinless Crank Retainer Kit w/7" Standoff
	1115516	Stainless Steel Pinless Crank Retainer Kit w/11" Standoff
1.	1703579	Stainless Steel Cap Screw - 3/8" x 1"
2.	1200999	Stainless Steel Hex Nut - 3/8"
3.	1703576	Stainless Steel Lock Washer - 3/8"
4.	1100574	Stainless Steel Cable w/#5 Interlock Snap
5.	1700526	Wire Lock Pin - 3/8" x 2 1/2"
6.	1100306	Retainer Bushing - 11/16"
7.	1118927	Stainless Steel J-Hook Crank Retainer
8.	1115514	Stainless Steel Pinless Crank Retainer
9.	1703619	Stainless Steel Cap Screw - 1/2" x 1 1/4"
10.	1115511	Stainless Steel Crank Retainer Standoff - 7"
	1115513	Stainless Steel Crank Retainer Standoff - 11"
11.	1703620	Stainless Steel Flat Washer - 1/2"
12.	1703577	Stainless Steel Flat Washer - 3/8"

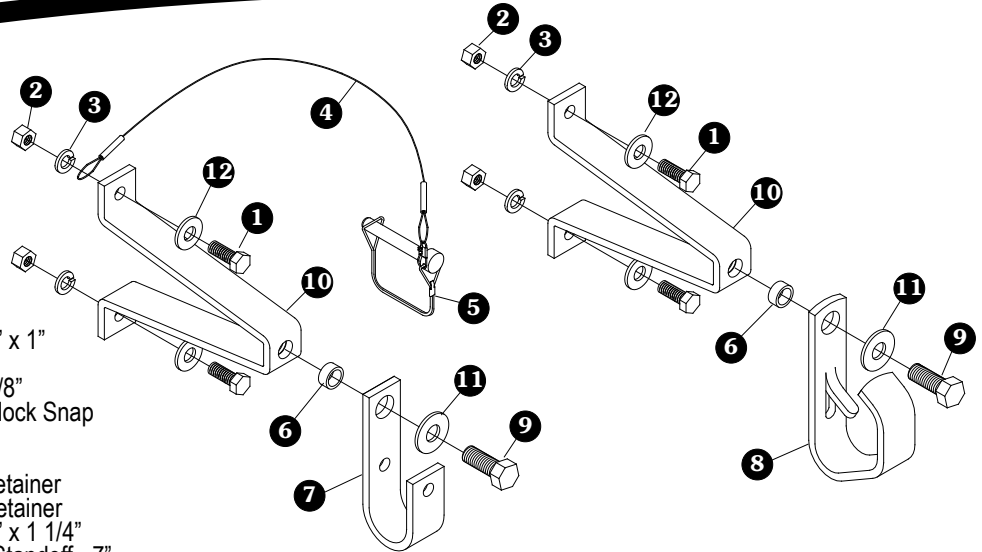

**Stainless Steel J-Hook Crank Retainer**

**Stainless Steel Pinless Crank Retainer**

**STEP 1:** Assemble crank retainers.

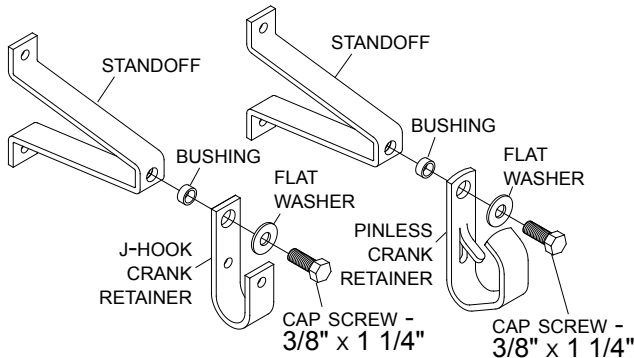

**STEP 2:** With tarp closed, rotate crank arm across rear of box to determine crank retainer location. Position crank retainer where it will hold crank arm securely in place.

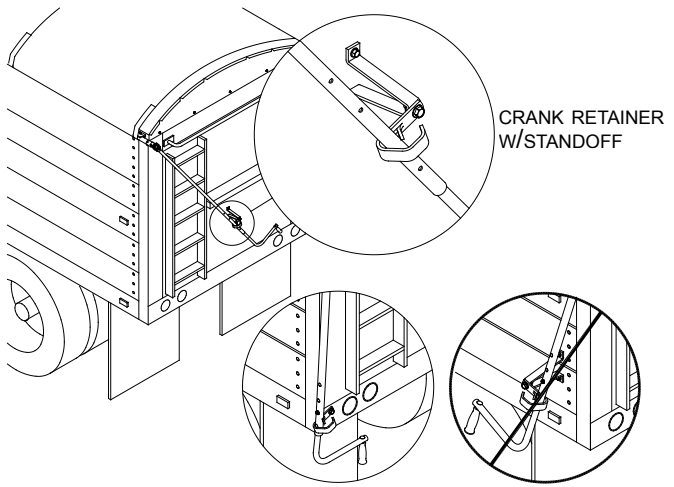

CRANK RETAINER W/STANDOFF  
CRANK RETAINER WITHOUT STANDOFF DO NOT MOUNT CRANK RETAINER ON SIDE OF BOX

**STEP 3:** Using standoff (or crank retainer) as a guide, mark and drill 13/32" holes in trailer. Fasten to box with 3/8" x 1" stainless steel cap screws, lock washers, flat washers and nuts. Fasten cable w/snap and wire lock pin between stand-off and box.

