



ENGINEERED TARPING SOLUTIONS

P/N 1112985 Rev. K

Installation Instructions



Electric Shur-Lok[®] End Dump

READ BEFORE INSTALLING

PO BOX 713 ■ 2309 SHUR-LOK STREET ■ YANKTON, SD 57078-0713
PHONE 1-800-4-SHUR-LOK (1-800-474-8756) ■ FAX 605-665-0501
www.shurco.com

SHOP ONLINE: www.shopshurco.com

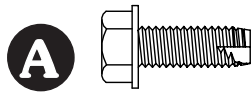

1700400 - Self-Tapping Screw - 3/8" x 1"

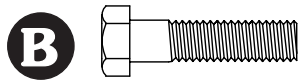

1701434 - Cap Screw - 3/8" x 1 1/2"



1700398 - Self-Drilling Screw - 1/4" x 3/4"



1703171 - Cap Screw, Nylon Lock - 5/16" x 1/2"

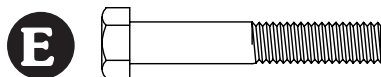

1702667 - Cap Screw - 3/8" x 2 1/4"

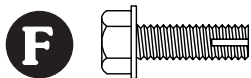

1701059 - Self-Tapping Screw - 5/16" x 1"



1700434 - Lock Washer - 3/8"



1700429 - Flat Washer - 3/8"

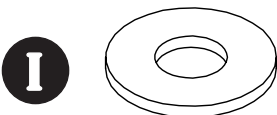

1702114 - Flat Washer - 1/2"



1700407 - Hex Nut - 3/8"



1700418 - Centerlock Nut - 3/8"



1702668 - Top Lock Nut - 3/8"



1700419 - Nylon Lock Nut - 5/16"

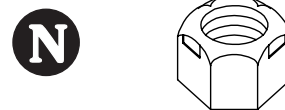

1700416 - Automation Lock Nut - 1/2"

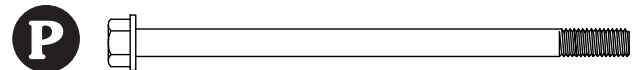

1702900 - Cap Screw - 1/2" x 9" (not to scale)

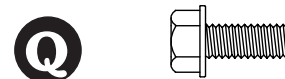

1701045 - Cap Screw - 5/16" x 3/4"



1700411 - Hex Nut - 5/16"

IMPORTANT: Read these instructions before installing the Electric Shur-Lok® option. Install the electric components after the front cap has been installed according to the Shur-Lok® owner's manual instructions. Before installing electric components on an existing Shur-Lok® system, remove the U-clamps, rear cap and U-joint/crank arm from the roll tube.

Rear End Cap - Aluminum/Fabric End Flap

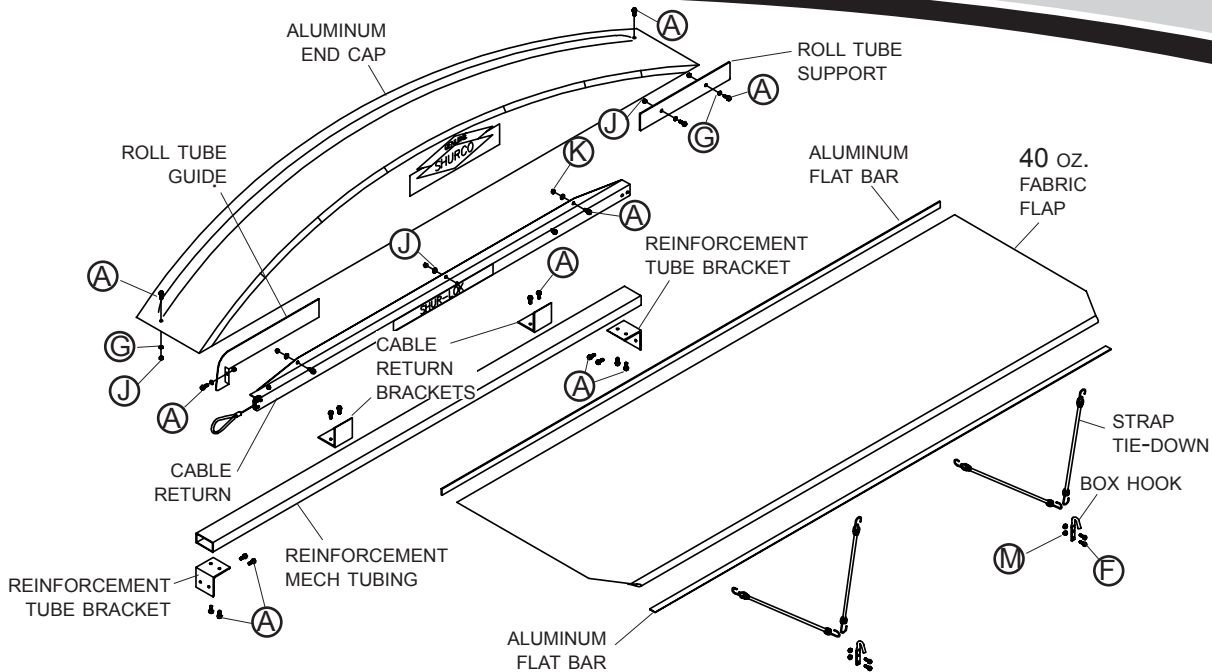

This cap/flap combination offers the support and return needed to guide the roll tube over the trailer during operation. The universal flap is cut to fit around the varying styles of hinges and gates found on end dumps.

STEP 1: Locate reinforcement tube bracket 5" forward of hinge pocket and 2" down from top rail. Mark top rail. Drill 5/16" holes, secure with screws **A**. Repeat on other side.

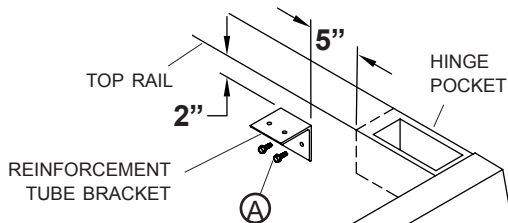

TIP: Place cap on trailer to test location of brackets. Be sure gate clears cap when open. The longer the hinge ear, the greater the distance brackets need to be from the tailgate.

STEP 2: Place reinforcement tube on brackets. Drill 5/16" holes and fasten with screws **A**.

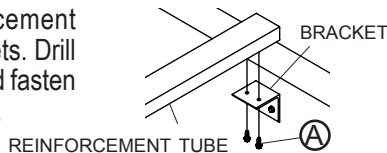

STEP 3: Measure and mark 34" and 62" from outside top rail (latchplate side). Align edge of cable return brackets at mark flush with back side of tube. Clamp in position. Drill 5/16" holes, fasten with screws **A**.

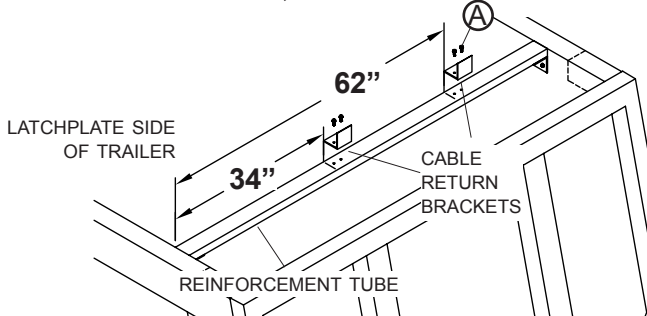

STEP 4: Position rear cap on top rails. Mark top rail locations on cap. Notch out cap so top panel rests firmly on top rail.

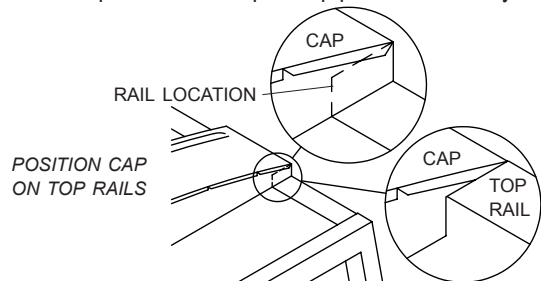

STEP 5: Install trim seal on outside edge of cap. Fasten cap to outside edges of top rail only. Drill 5/16" holes and secure with screws **A**.

NOTE: For optimal water run-off and tarp support, make sure end caps are level before fastening sides of caps to box. While fastening sides of caps to box, raise the center of the truss tube side of the cap to be level with, or slightly higher than the outside edge. Make sure cap is tight against reinforcement tube before securing ends of cap.

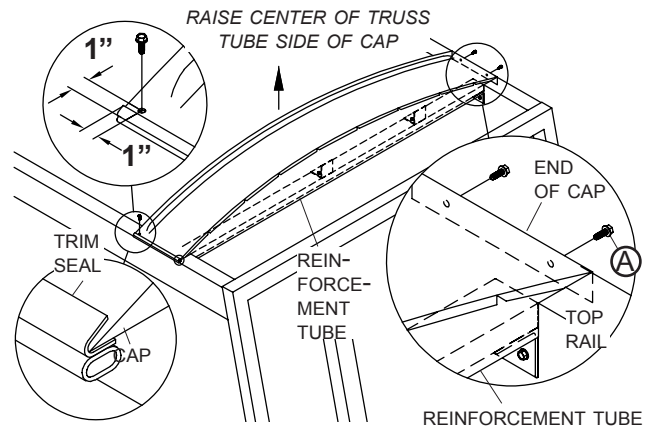

STEP 6: Lay flat bar on top rails against face of cap. Cut flat bar 1" shorter than inside box width (1/2" on each side).

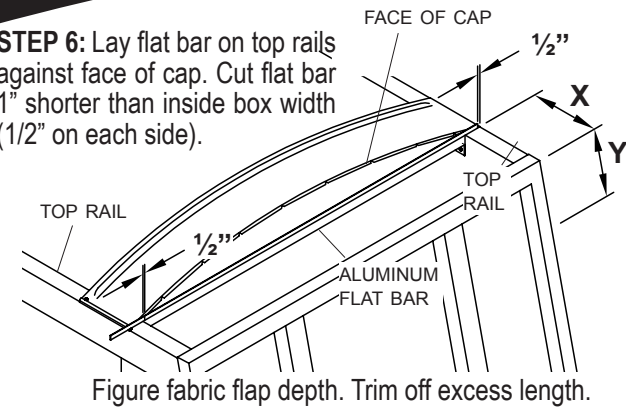
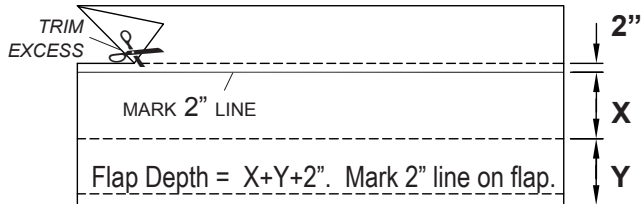
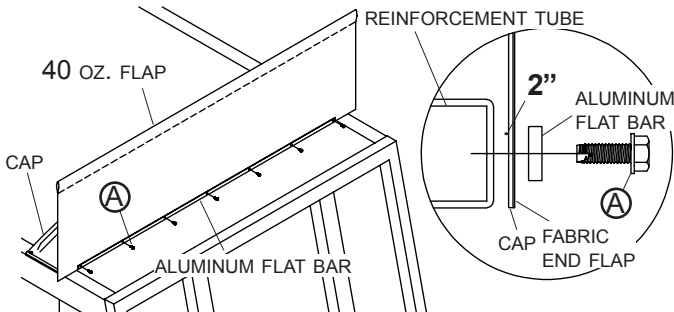

Figure fabric flap depth. Trim off excess length.



STEP 7: Position flap, then aluminum flat bar against cap. Clamp into position. Flap should be flush with bottom of cap and 2" line just above aluminum flat bar. Drill 5/16" holes through aluminum flat bar, fabric end flap and reinforcement tube. Secure with screw **A** in 7 locations.



TIP: Work from center of cap to outside edges, pulling fabric tight to keep flap free of wrinkles.

STEP 8: Position flap over rear gate. Insert flat bar into pocket of flap, cut to fit. Drill holes in flat bar and secure flap to gate with strap tie downs. Fasten box hooks with screws **F** and nuts **M**. Trim flap around gate/hinges.

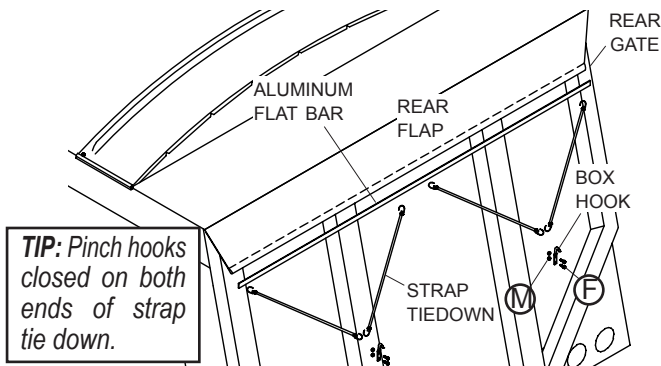

TIP: Pinch hooks closed on both ends of strap tie down.

STEP 9: Position straight roll tube support against cap extending 3 1/2" from end cap on fixed tube side. Drill 5/16" holes and secure with screws **A**, washers **G** and nuts **J**.

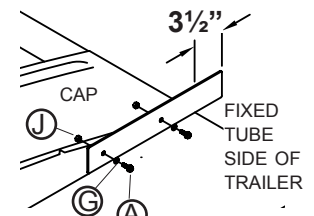

STEP 10: Position roll tube guide on the latchplate side top rail against cap. Drill hole and fasten with screw **A**, washer **G** and nut **J**.

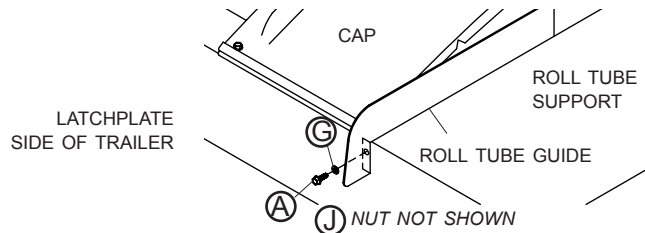

STEP 11: Cable return housing needs to extend 1/8" past, or be flush with outside edge of top rail. Measure and mark 36" and 64" from outside edge of top rail. Align pre-drilled holes in housing, making sure they are aligned with cable return brackets inside end cap. Mark location on face panel. Drill 5/16" holes and secure with screws **A** and nuts **K**.

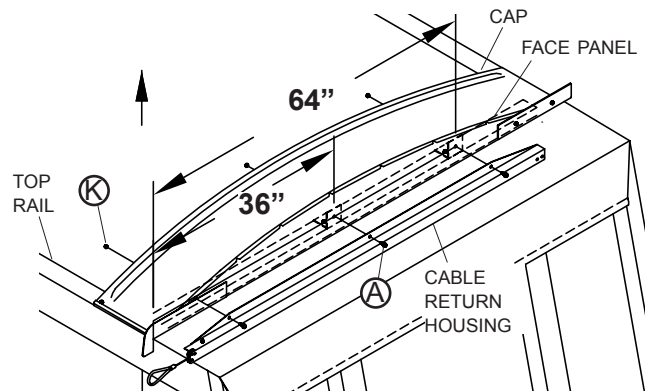

TIP: On narrow trailer with low rise caps, the first hole on return could miss end cap. Bolt return to aluminum guide. Drill fourth hole to ensure return is fastened to cap.

STEP 12: After roll tube has been installed, slip black cable loop around roll tube before operation.

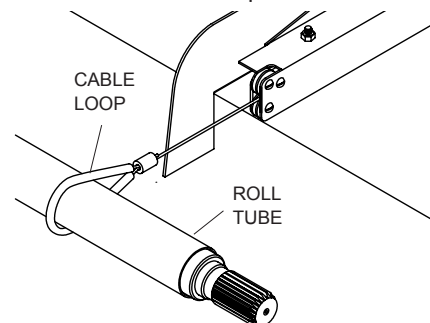

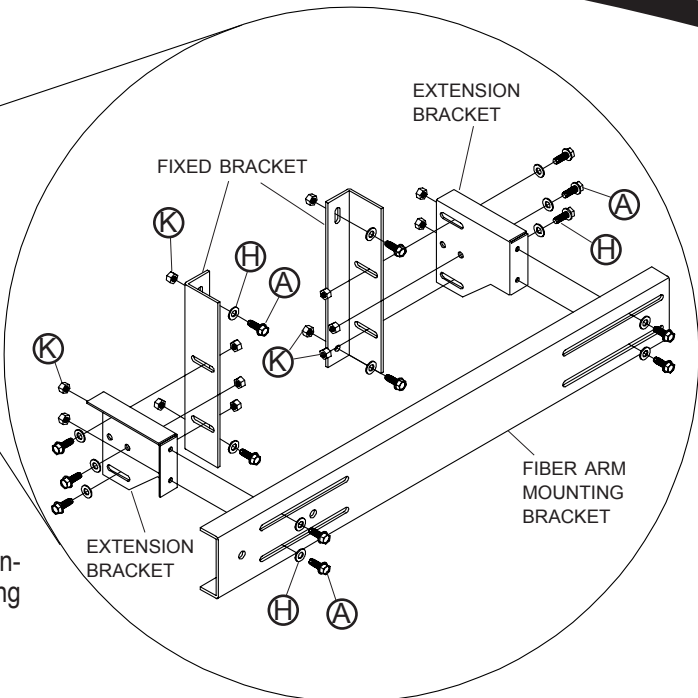
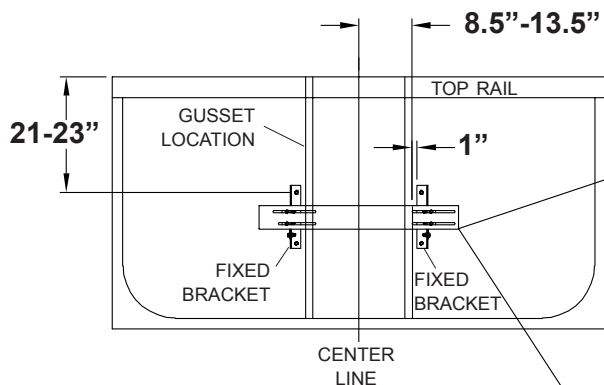

NOTE: When installing brackets, tighten bolts just enough to hold them in place. Square up the brackets to the front of the trailer before securing bolts.

Install bows, fixed tarp tube and ridge support as shown in owner's manual. Choose the correct style of trailer for the following installation procedures...

- 1) Vertical Front Trailer - proceed to step 13.
- 2) Slope Front Trailer - proceed to step 18.

STEP 13: Less than 96" wide: Measure and mark 48" from latchplate side of trailer. Consider this mark as the center of your trailer in the following steps.

STEP 14: 96" or 102" wide: Measure and mark 21" to 23" down from top rail at center of trailer.

STEP 15: Locate fixed brackets at mark, parallel to top rail. Place 1" to the outside of each gusset. Drill top hole with 5/16" bit and fasten with screws (A), washers (H) and nuts (K).

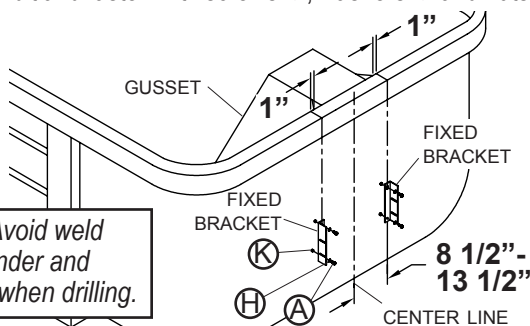

NOTE: Avoid weld ribs, cylinder and gussets when drilling.

STEP 16: Fasten extension bracket to fixed bracket with screws (A), washers (H) and nuts (K). Finger tighten nuts so brackets are an equal distance from front of trailer.

STANDARD MOUNTING PROCEDURE

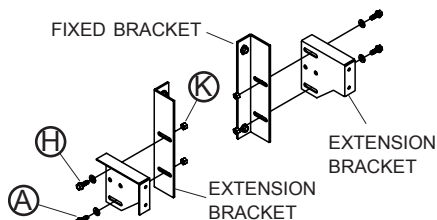

STEP 16 (Optional): Brackets may be mounted in opposite direction to accommodate varying front end styles. See fiber arm installation.

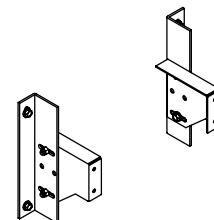

Optional Mounting

STEP 17: Fasten fiber arm mounting bracket to extension brackets with screws (A), washers (H) and nuts (K). Pre-drilled hole opposite latchplate side of trailer on mounting bracket should measure 19"±1" from center mark.

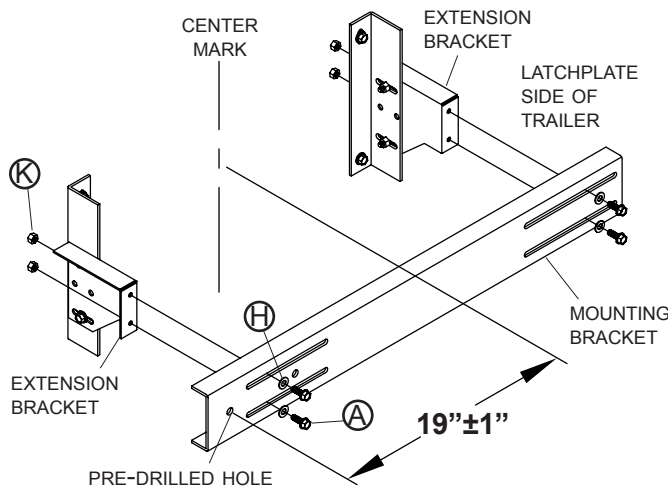

Go to **Fiber Arm Assembly** - step 22

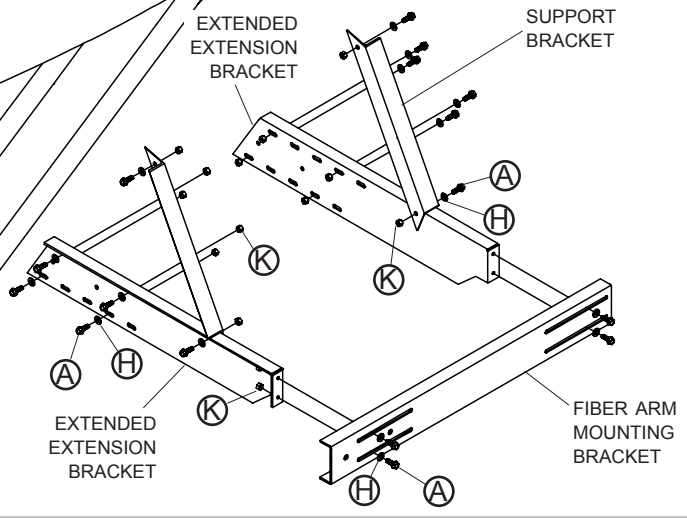
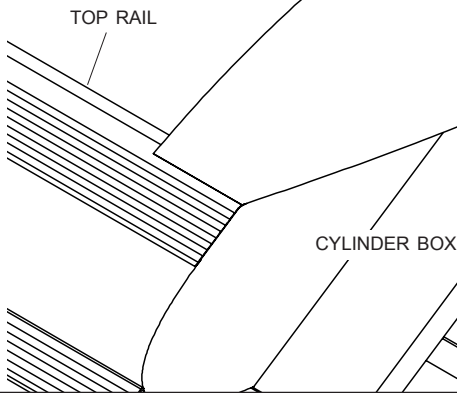

NOTE: When installing brackets, tighten bolts just enough to hold them in place. Square up brackets to front of trailer before securing bolts.

STEP 18: Using a level, find front cap rise (8" to 14") from top rail of the trailer. Add (25"±1") to determine bracket locations. Mark with line parallel to top rails on front and outside of cylinder box.

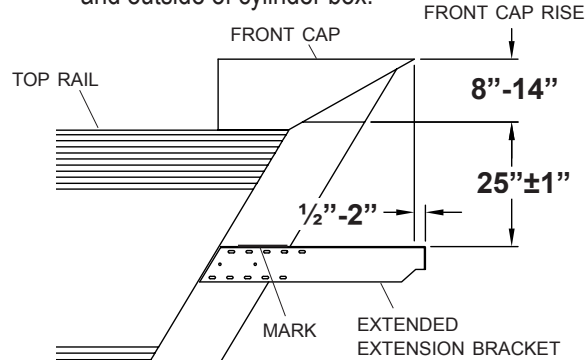

STEP 19: Locate bracket at marks. Predrill 5/16" holes and attach with screws (A) and washers (H) in two slotted locations. Cut end of extension bracket so front edge extends 1/2" to 2" beyond farthest point of front cap.

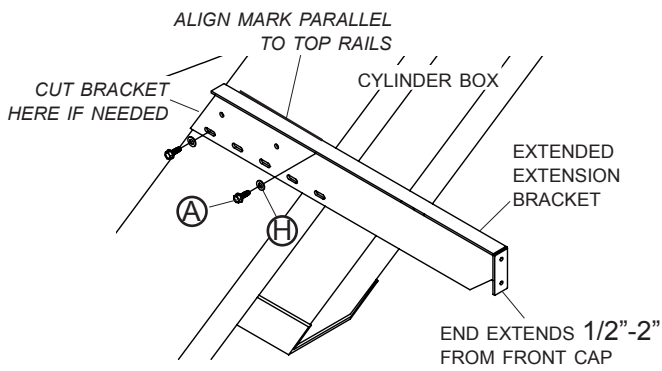

NOTE: It is very important that front brackets are mounted square with trailer. Check that brackets are perpendicular to trailer front and parallel to top rails.

STEP 20: Fasten fiber arm mounting bracket to extension brackets with screws (A), washers (H) and nuts (K). Align pre-drilled hole on fiber arm bracket 19"±1" from center of trailer.

TIP: Use a carpenter's square to make sure fiber arm mounting bracket is square with extended extension brackets.

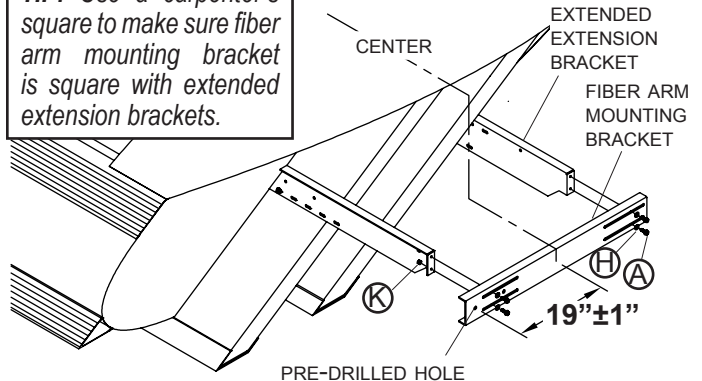

STEP 21: Install support brackets top and bottom with screws (A), washers (H) and nuts (K). Drill remaining slotted holes in extension bracket. Secure with screws (A) and washers (H).

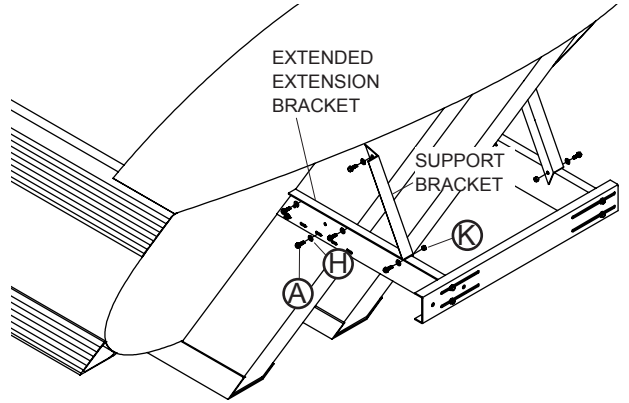

Fiber Arm Installation - Vertical or Sloped Front End Dump

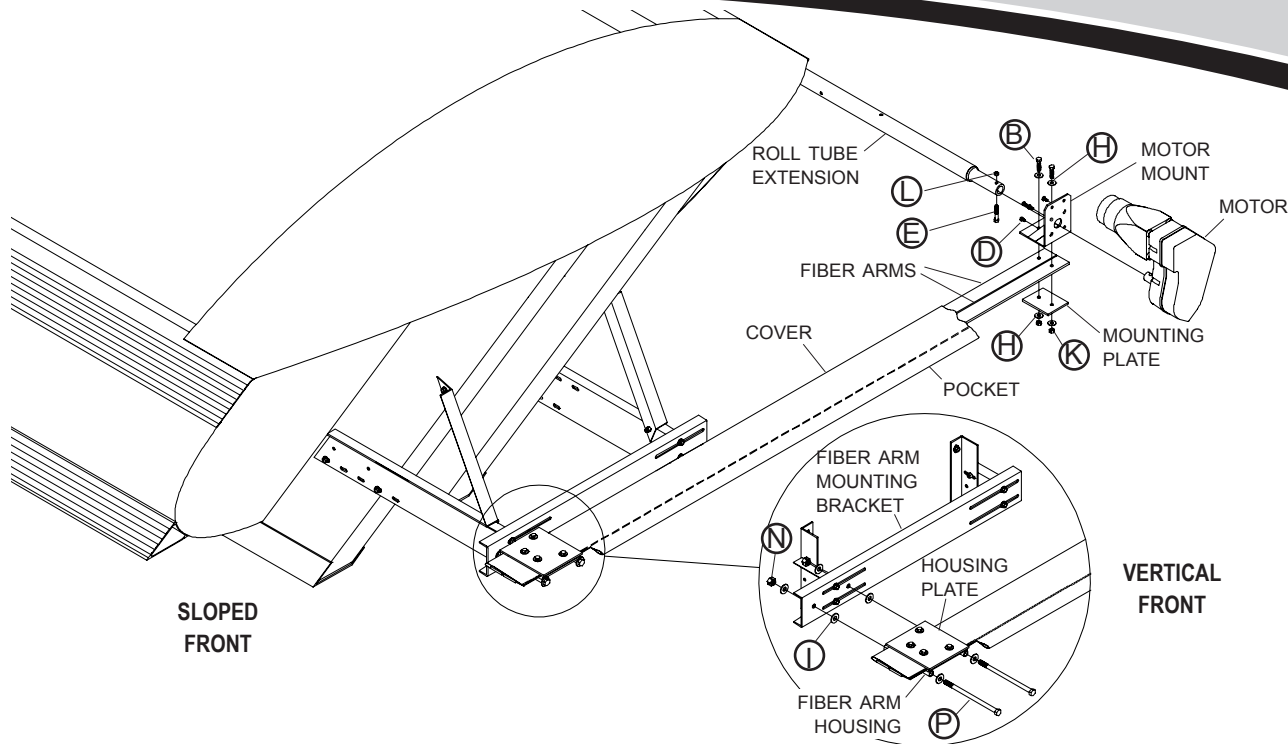

STEP 22: Working on a clean flat surface, slide fiber arms into cover. Match holes on cover with holes in fiber arms. Make sure pocket faces out.

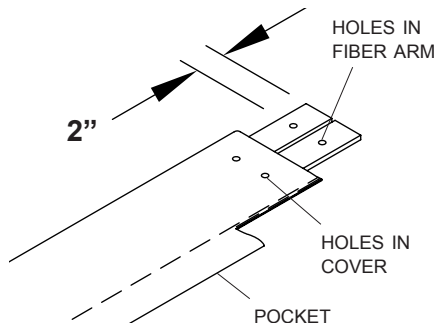

STEP 23: Position fiber arm between fiber arm plate and fiber arm housing. Fasten with screws (B), washers (E) and nuts (L) as shown.

NOTE: Do not tighten nuts at this time, just snug them up.

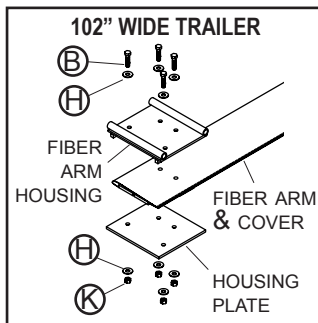
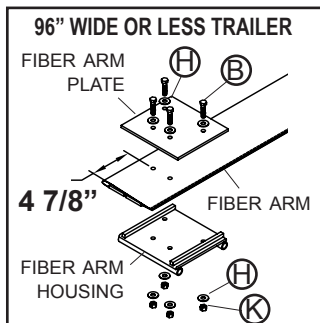

STEP 24: Slide mounting bracket horizontally so drilled hole is 19"±1" off center. Fasten arm with screws (D), washers (I) and nuts (N). Tighten.

NOTE: If screw (D) interferes with extension bracket, see step 17 for optional mount.

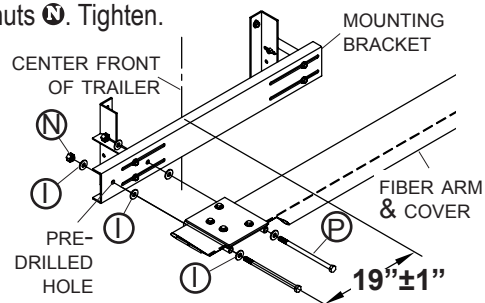

STEP 25: Fasten motor mount to motor with supplied screws.

ATTENTION:

- Use all mounting bolts when mounting gear motor.
- Do not use power tools.
- Do not overtighten (torque 5/16" x 7/8" Button Hd. Bolts to 70 in/lbs).
- Over tightening may crack case.
- Install star washers on the bolt side of the mounting plate.
- Do not use any form of thread locker.

NOTE: Before attaching motor to roll tube, coat bore and motor shaft with anti-seize for easy removal of the motor if necessary.

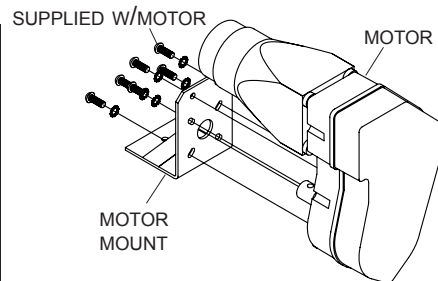

STEP 26: Distance X = distance from rear of trailer to front of fiber arm mounting bracket. Cut roll tube to $(X + 5\ 1/4" + 3" \text{ to } 6")$.

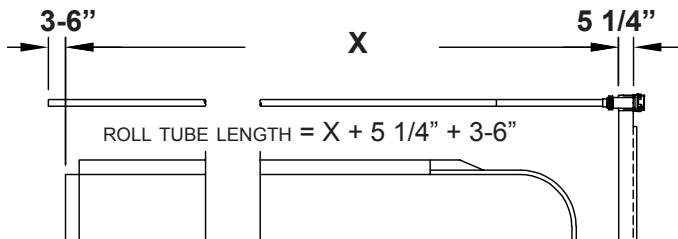

NOTE: See 'Tarp Tube Preparation' in Shur-Lok® owner's manual to splice roll tubes together.

STEP 27: Pull roll tube out of tarp at least 30". Mark and drill 3/8" holes through roll tube at right angles to each other in locations shown.

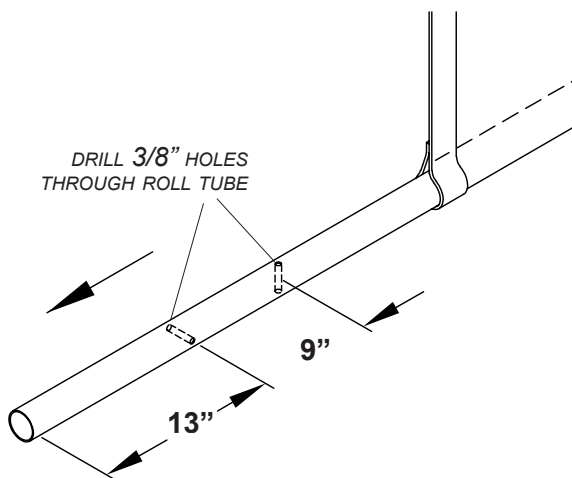

STEP 28: Insert roll tube extension w/drive shaft into roll tube. Weld and grind smooth. Let cool, then push roll tube back into tarp.

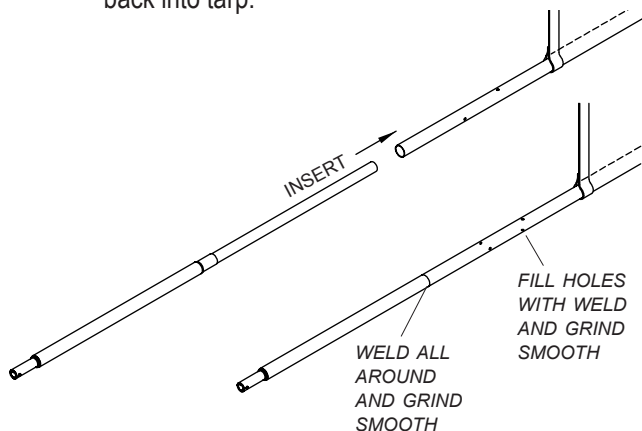

STEP 29: Insert motor shaft inside roll tube. Secure with **(L)** and **(I)**. Do not overtighten.

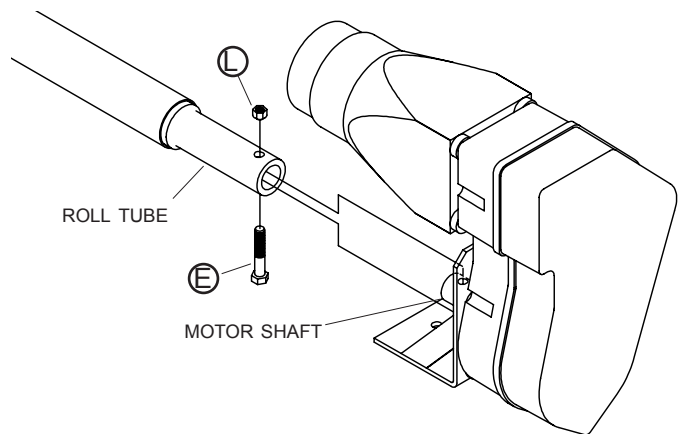

STEP 30: Position motor mount over arm and align holes. Insert screws **(B)** and washers **(J)** through motor mount and fiber arm. Slide mounting plate over bolts, add washers **(H)** and nuts **(K)**. Do not tighten.

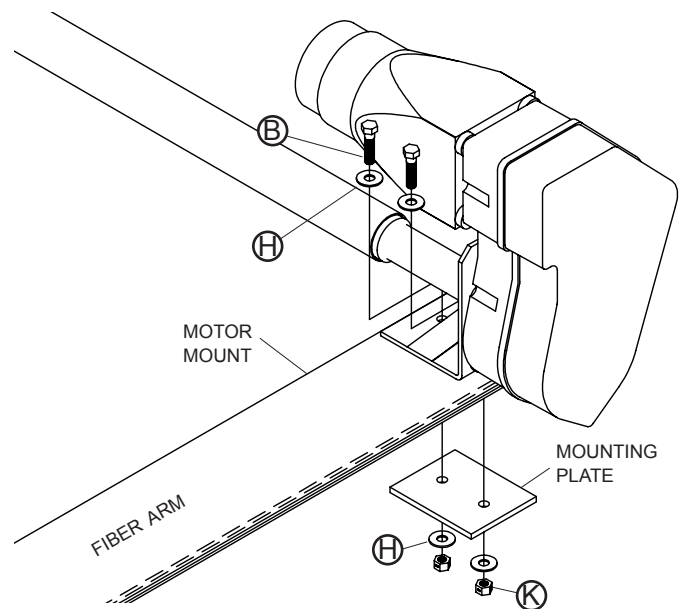

STEP 31: Adjust roll tube so that arm is parallel to trailer and mounting bracket. Check for 2" clearance between fiber arm/motor assembly and any obstructions on front of trailer. Re-install U-clamps. Tighten bolts that were installed in steps 23 and 30.

Square up system with trailer and install electric wiring and U-clamps. Test operation and tighten all bolts.

WIRING DIAGRAM

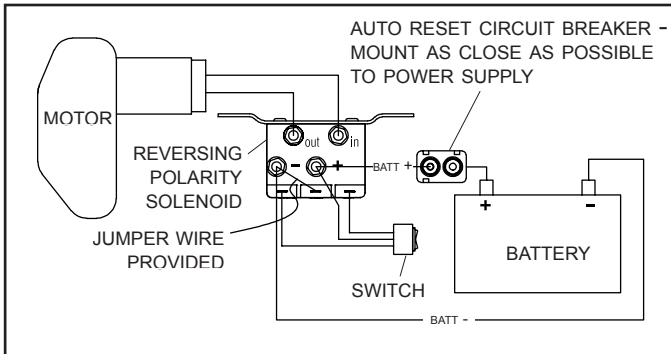

STEP 32: Run wire from front to rear of trailer and back to front, avoiding all pivot points. Feed wire over mounting plate, through pocket in fiber arm cover to motor. Connect wire to motor.

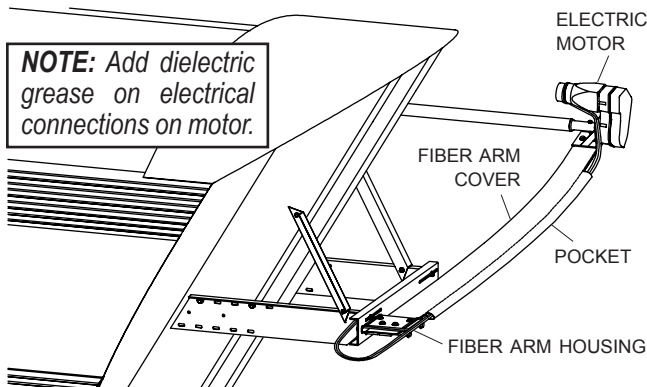

TIP: Run wire along other hydraulic lines to avoid pivot points so wire doesn't pinch between undercarriage and tub. Check operation first time so it doesn't tear wire apart.

STEP 33: Install dual conductor components and bracket to fifth wheel plate or to undercarriage of trailer. Do not fasten to tub. Connect remaining wire to plug.

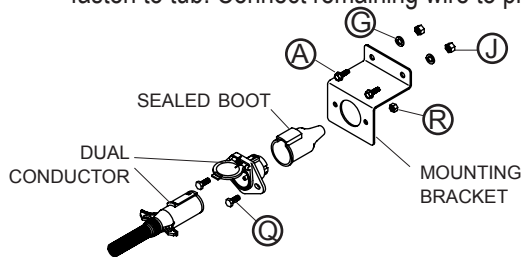

STEP 34: Make sure tarp is square with front of trailer and motor. Drill 3/16" holes through web, tarp and roll tube at front, rear and center of tarp. Fasten U-clamps and tightly secure with screws C.

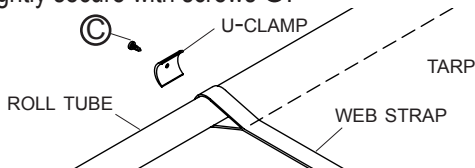

STEP 35: Operating System Checklist...

- Check that rear return is installed and operating correctly.
- Close tarp under latchplate. DO NOT Tighten ROLL TUBE UNDER LATCHPLATE until all U-clamps have been installed.

NOTE: If roll tube doesn't come under latchplate correctly, move fiber arm and mounting bracket away from latchplate side of trailer. Do not exceed 1". See Step 24 for illustration.

- Check tarp tension over bows.
- Check clearance (2" minimum) at front of trailer

STEP 36: When tarp tension looks good, install remaining U-clamps. See owner's manual to adjust tension.

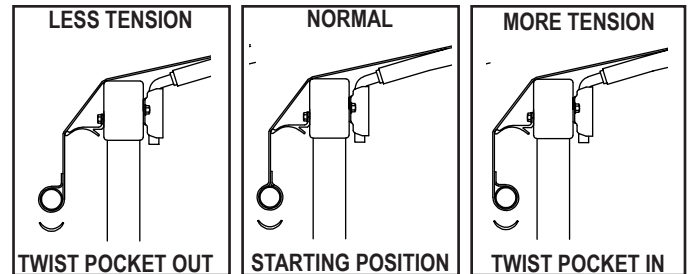

NOTE: Since end dumps vary in width from front to back, it may be necessary to set each U-clamp at a different location to fine tune tarp tension over end caps or bow locations.

STEP 37: Vertical or sloped front trailers: Tighten all nuts in front brackets. Make sure fiber arm mounting bracket is square with trailer. Install anchoring hardware - screws A, washers H and nuts I to keep mount from vibrating out of alignment during use. Secure all nuts and bolts.

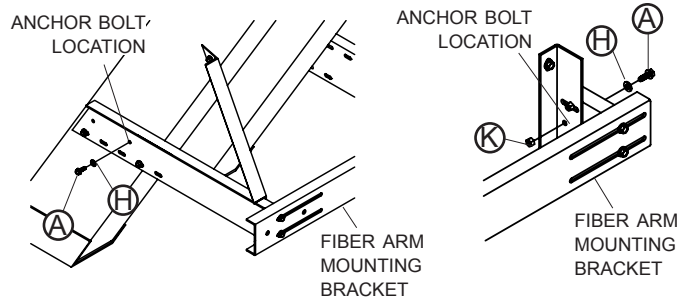

STEP 38: Install rivet on fixed tube near front tarp stop to keep tarp from sliding back during operation.

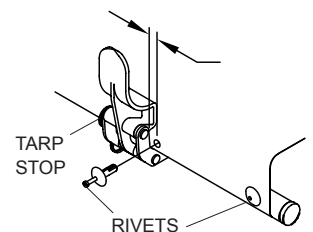

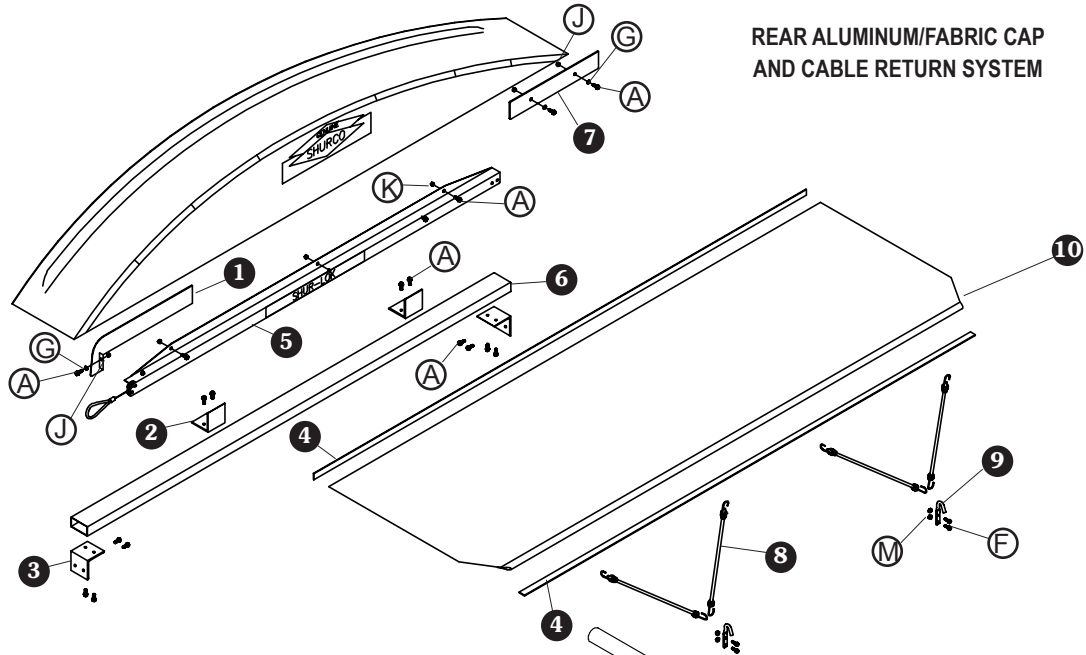

REAR ALUMINUM/FABRIC CAP AND CABLE RETURN SYSTEM

VERTICAL FRONT MOUNTING BRACKETS

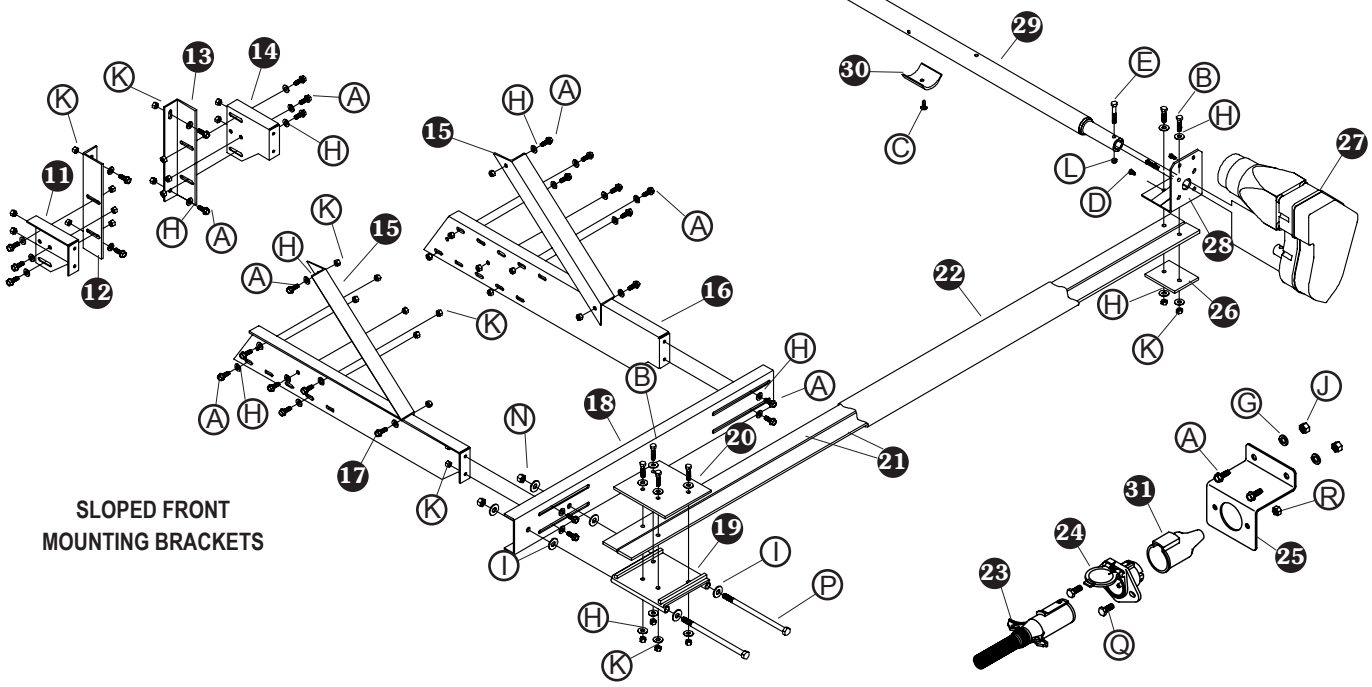

SLOPED FRONT MOUNTING BRACKETS

DUAL CONDUCTOR

Item	Part #	Description
1.	1113016	Roll Tube Guide
2.	1112953	Cable Return Bracket
3.	1112952	Reinforcement Tube Bracket
4.	1113020	Aluminum Flat Bar - 1/8" x 1" x 99"
5.	1112999	Heavy-Duty Rear Cable Return
6.	1702530	Mechanical Tubing - 4" x 2" x 100 1/2"
7.	1113017	Roll Tube Support
8.	1700990	Shock Cord
9.	1700682	Box Hook - 5/16" Holes
10.	1113035	Rear 40 oz. Vinyl Flap - Black
11.	1112233	Pass. Side Extension Bracket
12.	1112232	Pass. Side Fixed Base Mtg. Bracket
13.	1112748	Driver Side Fixed Base Mtg. Bracket
14.	1112749	Driver Side Extension Bracket
15.	1112310	Extended Extension Support Bracket
16.	1113307	Driver Side Extended Extension Bracket
17.	1113306	Pass. Side Extended Extension Bracket
18.	1112178	Fiber Arm Mounting Bracket
19.	1112932	Fiber Arm Housing
20.	1112675	Fiber Arm Housing Plate
21.	1112929	Fiber Arm
22.	1112165	Fiber Arm Cover
23.	1115385	Heavy-Duty Dual Conductor Plug
24.	1115386	Heavy-Duty Dual Conductor Socket
25.	1112890	Dual Conductor Mounting Bracket
26.	1112307	Motor Mount Mounting Plate
27.	1703135	Tarp Stretcher Electric Motor
28.	1112309	Motor Mount Weldment
29.	1112954	Roll Tube Extension w/Drive Shaft
30.	1701354	U-Clamp
31.	1704573	Conductor Socket Sealing Boot
	1116271	Electric Parts Kit w/Rocker Switch
A.	1700400	Self-Tapping Screw - 3/8" x 1"
B.	1701434	Cap Screw - 3/8" x 1 1/2"
C.	1700398	Self-Drilling Screw - 1/4" x 3/4"
D.	1703171	Nylon Lock Cap Screw - 5/16" x 1/2"
E.	1702667	Cap Screw - 3/8" x 2 1/4"
F.	1701059	Self-Tapping Screw - 5/16" x 1"
G.	1700434	Lock Washer - 3/8"
H.	1700429	Flat Washer - 3/8"
I.	1702114	Flat Washer - 1/2"
J.	1700407	Hex Nut - 3/8"
K.	1700418	Centerlock Nut - 3/8"
L.	1702668	Top Lock Nut - 3/8"
M.	1700419	Nylon Lock Nut - 5/16"
N.	1700416	Automation Lock Nut - 1/2"
P.	1702900	Cap Screw - 1/2" x 9"
Q.	1701045	Cap Screw - 5/16" x 3/4"
R.	1700411	Hex Nut - 5/16"

MORE QUALITY PRODUCTS FROM SHUR-CO®

- Value Series Shur-Lok®
- Super Duty Shur-Lok®
- Value Series Belt & Ratchet
- Premium Belt & Ratchet
- Shur-Lok® Junior
- Cable-Lok™ Spool Tarp
- 3500 Series Electric Shur-Lok®
- Value Series Electric Shur-Lok®
- Super Duty Electric Shur-Lok®
- SMARTrailer™ Accessories
- SMARTransmitter®
- ProTrap® Electric Hopper Door Opener
- Electric Turning Point™ Bow System
- Shur-Trak II™ Cable System
- Cover-Pro II® Cable System
- UltraSteel Arm System
- Arm-Matic™ Arm System
- Fitted & Flat Covers
- Turning Point™ Bow System
- Combine Hopper Ext. Covers
- Stock & Custom Flatbed Tarps
- Load Control Line
- Genuine Replacement Tarps
- Genuine Replacement Parts
- Solar Power Pack

ENGINEERED TARPING SOLUTIONS

