

## STEP 1 - Locate & Drill Holes

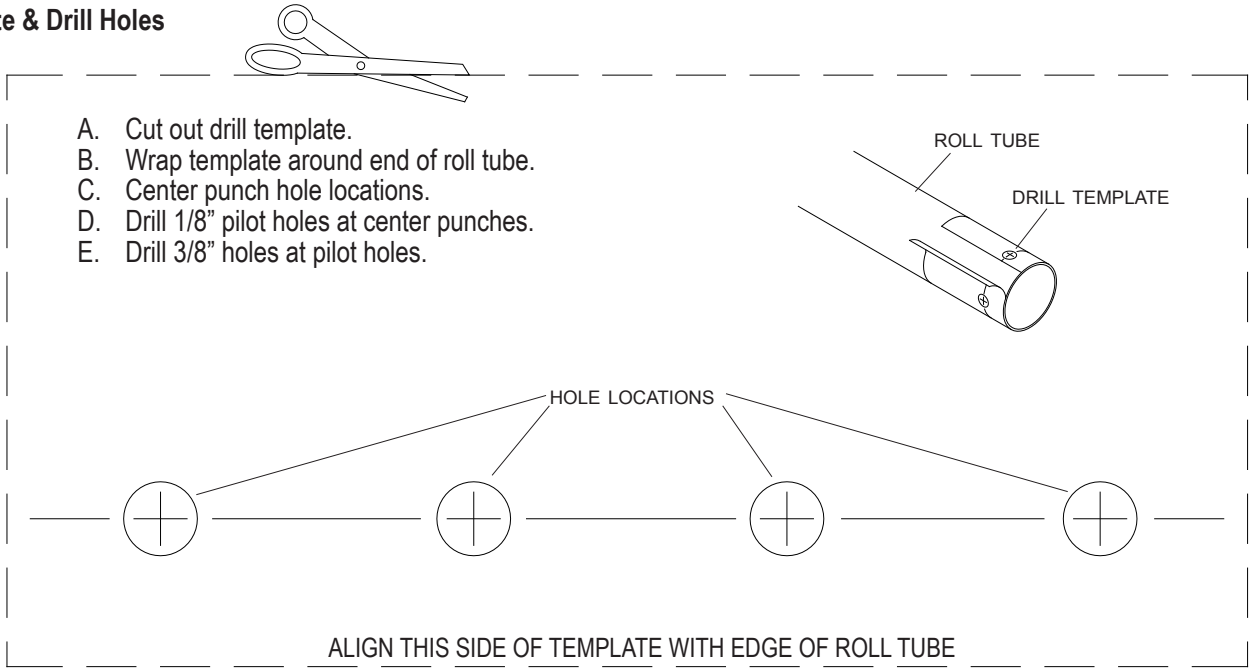

## STEP 2 - Assemble & Weld

- A. Insert Wil-Slip Joint into end of roll tube, aligning dimples in cast housing with holes in roll tube.

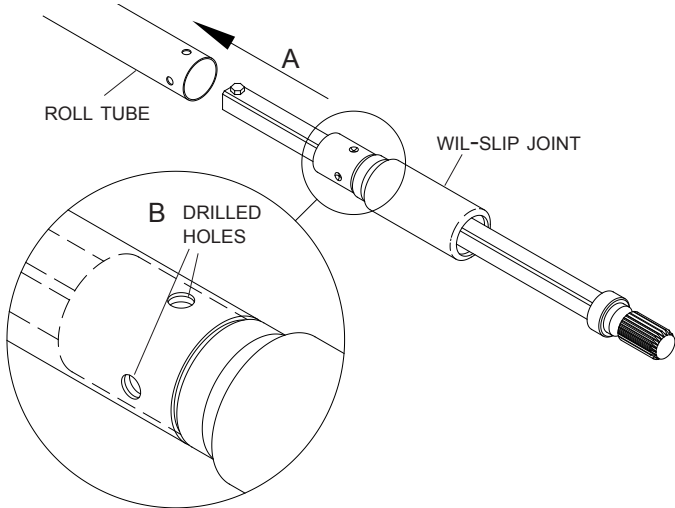

- B. Weld into drilled holes, filling holes with weld until flush with roll tube.

*Weld into drilled holes one at a time, allowing part to cool between welds. Excessive heat could damage plastic bushing.*

**WELD INTO DRILLED HOLES ONLY  
 DO NOT WELD AROUND ROLL TUBE**

## STEP 3 - Install U-Clamps

*Install U-clamps after installing tarp.*

- A. Fasten tarp to roll tube with U-clamps and 1/4" x 3/4" self-drilling screws (see owner's manual).  
 B. To prevent interference with Wil-Slip Joint, remove screw at end of roll tube. Grind end to shorten, and replace.

