

Item	Part #	Description
1.	1118585	Stop Hook - 1 1/8"

**STEP 1:** Weld stop hooks 1" from rack. Edge of hook should contact existing plastic wear plate.

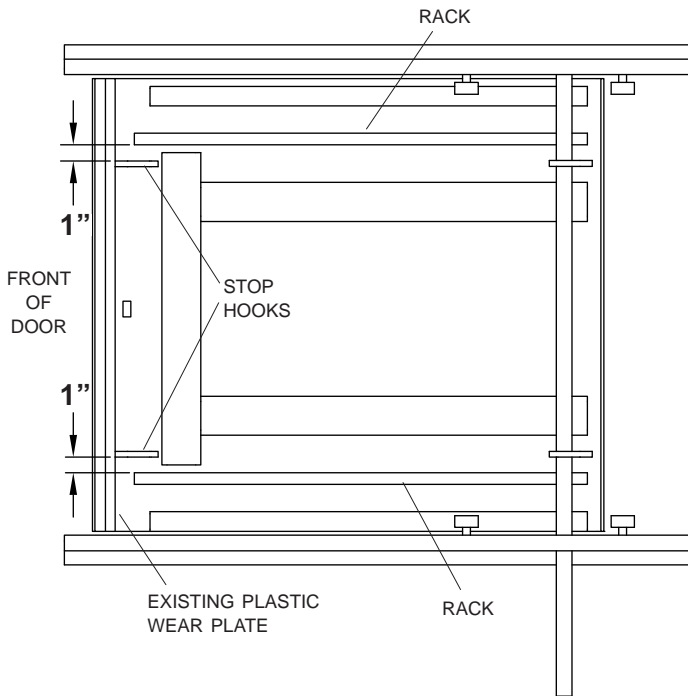

**STEP 2:** Close door completely, so door is against existing stop.

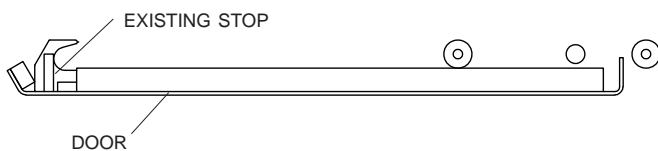

**STEP 3:** Locate hooks on trailing side of door to stop door at this location.

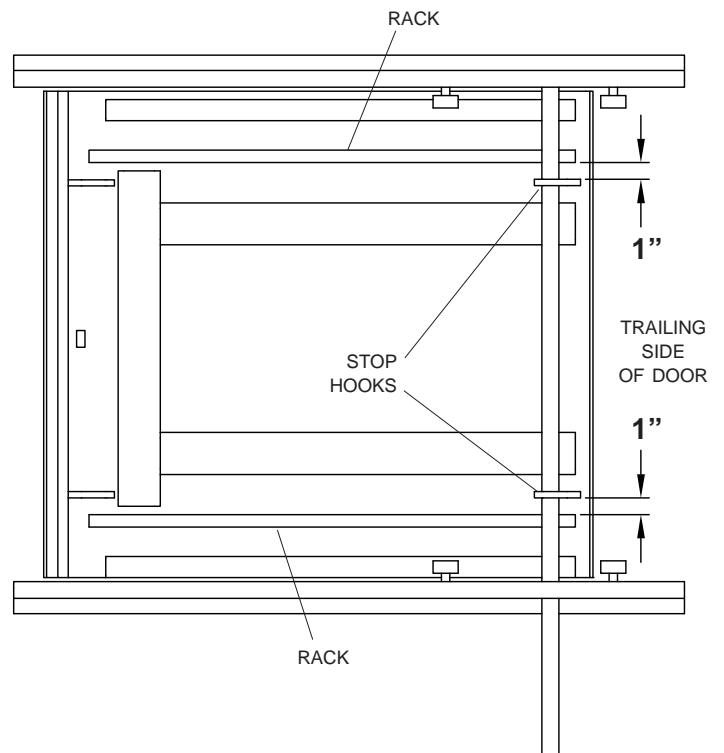

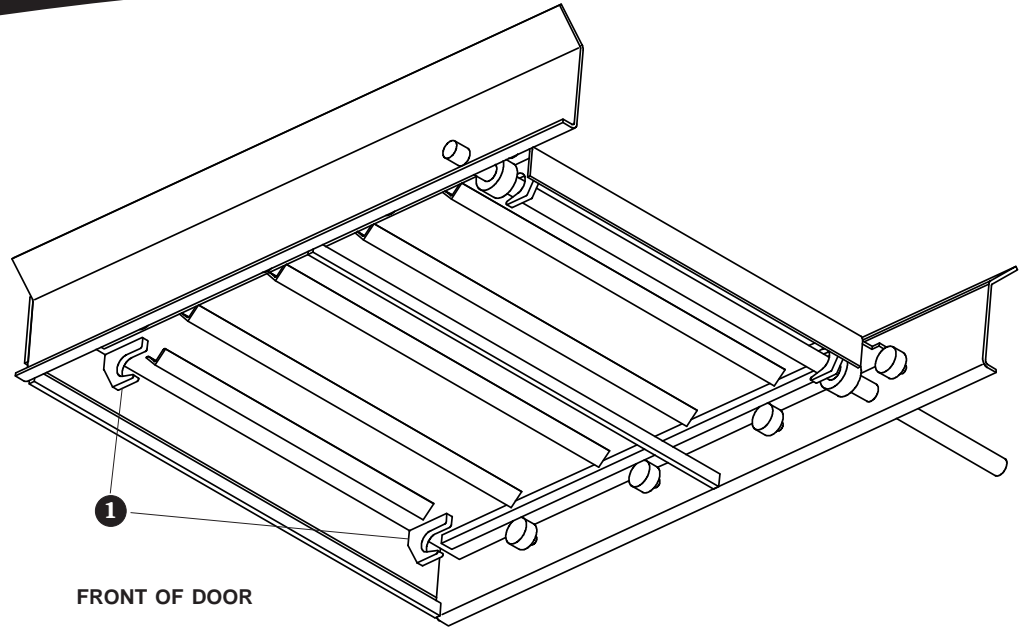

Item	Part #	Description
1.	1118585	Stop Hook - 1 1/8"
	1118745	Stop Hook - 5/8"

FRONT OF DOOR

**STEP 1:** Select hook. Taller hook is generally used with 1" cross shafts; shorter hook is used with 3/4" shafts. Hook should pull rack and pinion together, while stopping door by capturing cross shaft.

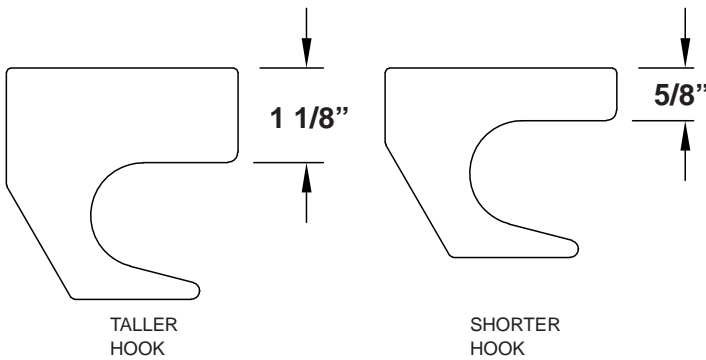

**STEP 2:** Close door to existing stop (not shown due to trailer variations). Remove bracing on bottom of door frame as needed.

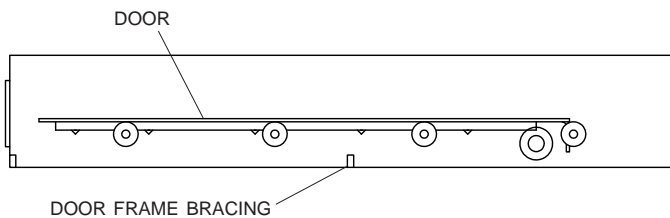

**STEP 3:** Weld hooks to trailing side of door within 2" of pinion gear. Open door to locate hooks on front side. Weld hooks to door. Replace bracing on bottom door frame. Allow adequate clearance between bracing and stop hooks on door.

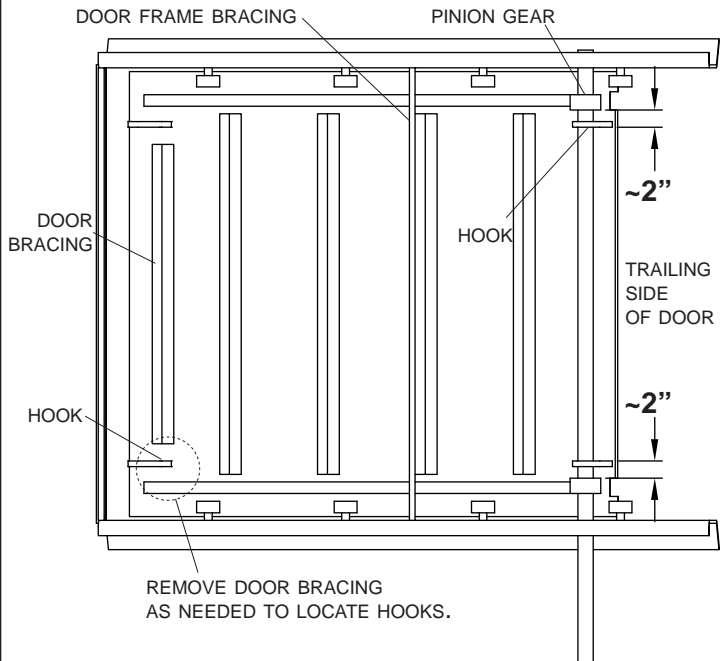

**CAUTION**  
Failure to replace braces could result in damage to door and frame!

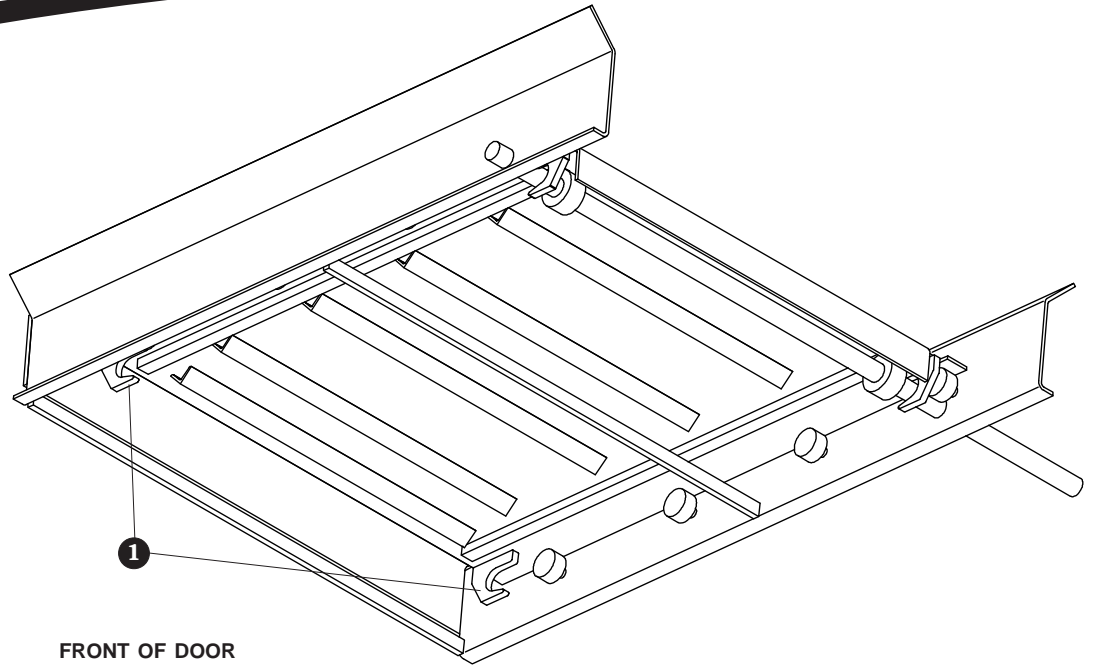

Item	Part #	Description
1.	1120472	Stop Hook - 1"

FRONT OF DOOR

**STEP 1:** Close door to existing stop (not shown due to trailer variations).

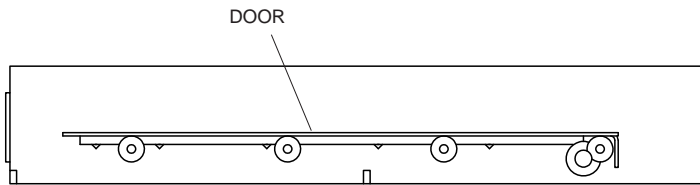

**STEP 2:** Weld hooks to trailing side of door within 2" of pinion gear. Open door to locate hooks on front side. Weld hooks to door.

