



ENGINEERED TARPING SOLUTIONS

P/N 1120423 Rev. A

OWNER'S MANUAL



Shur-Link™ Pro

READ BEFORE INSTALLING

PO BOX 713 ■ 2309 SHUR-LOK STREET ■ YANKTON, SD 57078-0713
PHONE 1-800-4-SHUR-LOK (1-800-474-8756) ■ FAX 605-665-0501
www.shurco.com

SHOP ONLINE: www.shopshurco.com

MESSAGE TO OWNERS

Thank you for buying this product from Shur-Co®. We appreciate your confidence in our products. Please read and thoroughly understand this manual before installing and/or operating this system.

Pay particular attention to important safety and operating instructions, as well as warnings and cautions. The hazard symbol  is used to alert users to potentially hazardous conditions and is followed by caution, warning or danger messages.

Failure to READ AND FOLLOW INSTRUCTIONS could result in failure of your system and/or personal injury. Your trailer requirements may, however, call for minor variations to these instructions.

Please inspect your system periodically. Repair or replace worn or damaged parts to your system.

QUESTIONS? CALL OUR HELP LINE:

1-866-748-7435

MON-FRI 8 AM-5 PM CENTRAL TIME

SAFETY

We at Shur-Co® are concerned with your safety and the safety of all those operating this system. Therefore, we have provided safety decals at various locaitons on your system. Keep decals as clean as possible at all times. Replace any decal that has become worn or damaged, painted over or otherwise difficult to read. Replacement decals are available through Shur-Co® dealers.

SAFETY INSTRUCTIONS

- 1. Always wear safety glasses during installation.**
- 2. Keep body and clothing clear of moving parts.**
- 3. No other use of this system is authorized, except as designed.**

RUST PREVENTION

To prevent rust, paint all exposed metal, such as weld seams and/or metal exposed by grinding or cutting, with corrosion-resistant paint.

TABLE OF CONTENTS

Shur-Link™ Pro Benefits & Advantages..... 1

Shur-Link™ Basic Operation2 - 3

Program SMARTransmitter® to Shur-Link™ Pro.....4

Hardware Identification5

Shur-Link™ Signal Light Installation6

Control Module Installation7 - 8

Electrical Wiring - Shur-Link™ to Power9

Electric Wiring - Wiring Diagrams 10

3500 Series Electric Wiring Installation 11

ProTrap® Electric Wiring Installation 12

3500 Series & ProTrap® Electric Wiring Installation 11 - 12

Replacement Parts 13

Terms & Conditions 14

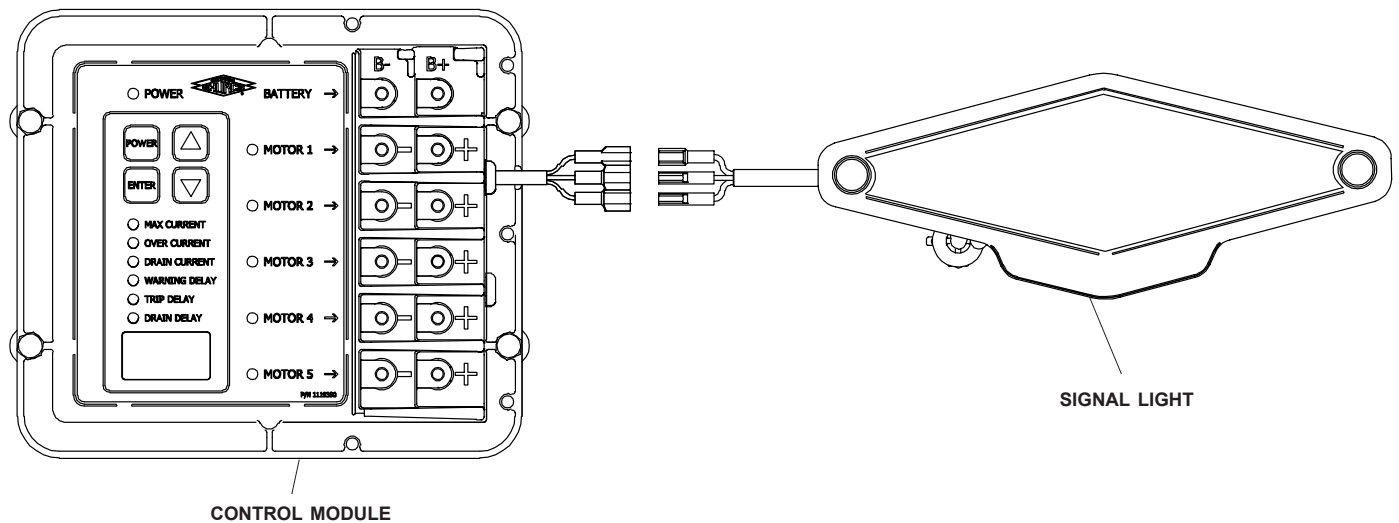

The Shur-Link™ system provides active protection to all motorized systems (3500 Series, ProTrap, etc.) connected to it by continuously measuring the current drawn by the systems.

In the case of a motor stall, as when the end-of-travel is reached, the Shur-Link™ will signal the stall condition via a flashing high intensity LED signal light. If the condition persists, the Shur-Link™ will protect the motor and other system components by disconnecting all connected systems from the vehicle battery. The high intensity LED signal light will continuously flash in order to indicate a "tripped" condition until the Shur-Link™ is manually reset.

In the case of a short-circuit, the Shur-Link™ will protect all connected systems by immediately disconnecting them from the vehicle battery. As with a prolonged stall condition, the high intensity LED signal light will continuously flash in order to indicate a "tripped" condition until the Shur-Link™ is manually reset.

Fault indicators and a digital display on the Shur-Link™ can help to pinpoint the cause of any unintended operation.

In addition to motor protection, the Shur-Link™ can be used to intentionally connect or disconnect the vehicle battery from the systems hooked up to it. This can be done with the press of a button on the Shur-Link™, or from a SMARTransmitter®. The Shur-Link™ will provide *POWER ON* or *POWER OFF* status via the high intensity LED signal light. When the light is on, all systems hooked up to the Shur-Link™ are tied to the vehicle battery. When the light is off, all systems hooked up to the Shur-Link™ are disconnected from the battery and will not operate.

Normal Operation:

- Signal light is off when Shur-Link™ is turned off.
- Signal light is on continuously when Shur-Link™ is on, and when motors are operating normally (not stalling).
- Signal light is flashing (twice per second) when a motor has stalled or reached 'end of travel'. Release command button or switch when light begins to flash.

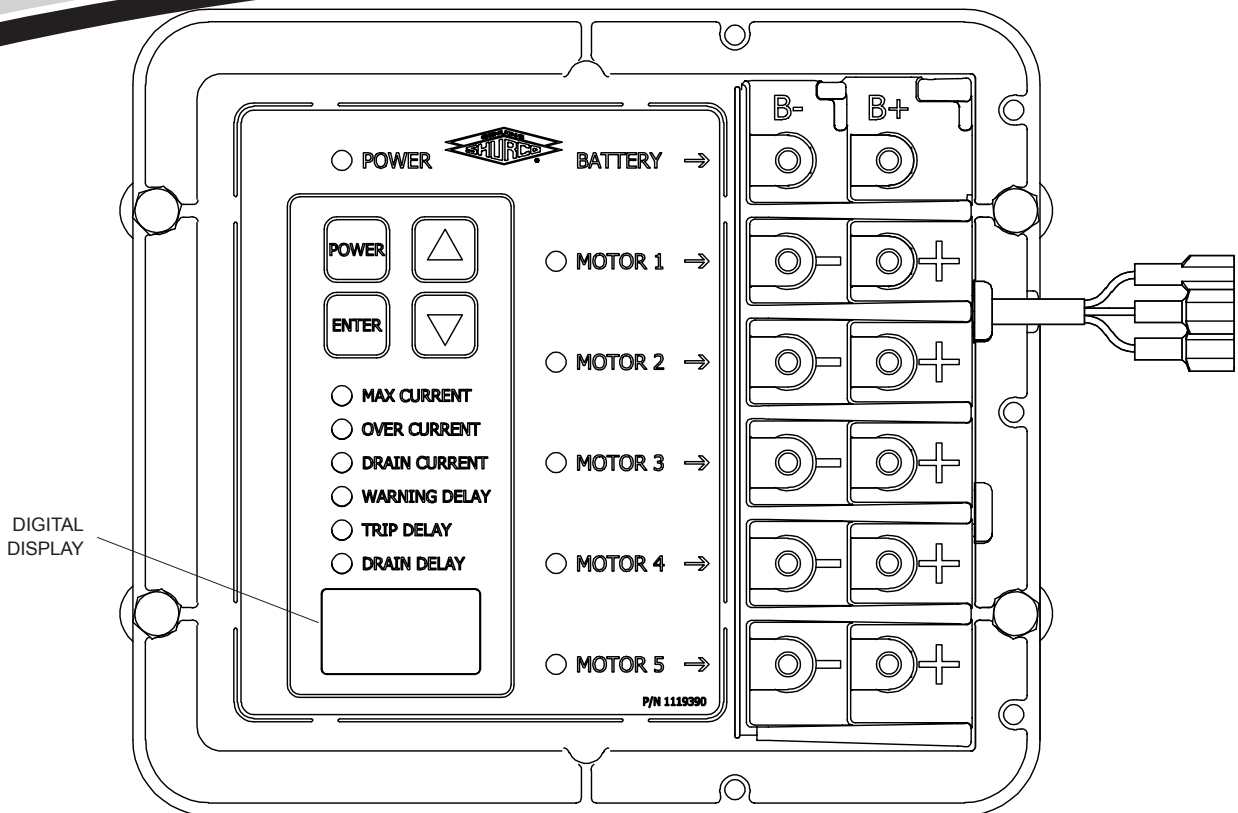

SHUR-LINK™ CONTROL MODULE

Power-up/down:

The Shur-Link™ can be turned on and off from the *POWER* button located on the control module and from the SMARTtransmitter®. For the SMARTtransmitter® to work with the Shur-Link™, the Shur-Link™ signal light must be connected to the control module and the transmitter must be programmed to the control module.

While the Shur-Link™ is turned on, all motors or other systems connected will be linked to the power supply (vehicle battery). If the Shur-Link™ is turned off, all power will be disconnected.

Short circuit detection:

If the Shur-Link™ is turned on and it immediately detects a short circuit or a load greater than about one amp, it will immediately trip and display *SC1* on the digital display located on the control module. The *POWER* LED and signal light will flash quickly for about five seconds and then flash slowly. In order to reset the control module, it must be turned off, the short circuit or load must be removed and then the Shur-Link™ can be turned back on.

Shur-Link™ Pro Output Channels:

- BATTERY → Power
- MOTOR 1 → Pup Wiring
- MOTOR 2 → 3500®
- MOTOR 3 → ProTrap®
- MOTOR 4 →
- MOTOR 5 →

Max current: If the current on any channel exceeds the *MAX CURRENT* limit for that channel, the system will immediately trip. The trip current will remain displayed on the digital display and the *MAX CURRENT* LED will turn on. The *POWER* LED and channel LED (*MOTOR 1*, *MOTOR 2*, etc.) will start to flash (once every two seconds) to indicate that the control module has tripped and exceeded the max current. In order to reset the control module, it must be turned off and then turned back on by either the SMARTtransmitter® or by the *POWER* button located on the control module.

Max Current Limits:

- MOTOR 1 → 150A
- MOTOR 2 → 150A
- MOTOR 3 → 150A
- MOTOR 4 → 150A
- MOTOR 5 → 100A

If *MAX CURRENT* is obtained, this would indicate that there is a short circuit located somewhere between the control module and the system designated by the flashing channel LED located on the control module.

Over current: If the current on any channel exceeds the *OVER CURRENT* limit for that channel, the *OVER CURRENT* LED will turn on after a one-second delay. The *POWER* LED and channel LED (*MOTOR 1*, *MOTOR 2*, etc.) will start to flash quickly (twice every second) to indicate that the channel is in an over-current condition. If the *OVER CURRENT* limit is exceeded for another 15 seconds, the Shur-Link™ Pro will trip and disconnect all systems from power. The trip current that was measured by the control module will remain displayed on the digital display and the *OVER CURRENT* LED will stay on. The *POWER* LED and channel LED (*MOTOR 1*, *MOTOR 2*, etc.) will flash (once every two seconds) to indicate which system caused the fault. In order to reset the control module, it must be turned off and then turned back on by either the SMARTtransmitter® or by the *POWER* button located on the control module.

Over Current Limits:

MOTOR 1 → 80A
 MOTOR 2 → 60A
 MOTOR 3 → 40A
 MOTOR 4 → 30A
 MOTOR 5 → 15A

Drain current: The Shur-Link™ Pro will monitor the current on each of the five output channels. If any one of these channels draws more than 5A, the *DRAIN CURRENT* LED and the channel LED (*MOTOR 1*, *MOTOR 2*, etc.) will turn on.

NOTE: The *DELAY* LEDs shown on the control module are not used in this application.

SHUR-LINK™ SIGNAL LIGHT

The LED on the Shur-Link™ signal light will remain solidly lit as long as the Shur-Link™ system is activated.

Max current: The signal light will start to flash (once every two seconds) to indicate that the Shur-Link™ control module has tripped. In order to reset the control module, it must be turned off and then turned back on by either the SMARTtransmitter® or the *POWER* button located on the control module.

Over current: The signal light will flash quickly (twice per second) to indicate that the Shur-Link™ control module has detected high current (more than the "over current" limit). This flashing will continue for up to 15 seconds before the control module will trip and disconnect all systems from power. Once the control module trips, the signal light will flash (once every two seconds). In order to reset the control module, it must be turned off and then turned back on by either the SMARTtransmitter® or the *POWER* button located on the control module.

SHUR-LINK™ FAULT TROUBLESHOOTING

If Shur-Link™ turns off and signal light is off (not flashing):

- Check if any circuit breakers have tripped between the battery and the Shur-Link™. If they have tripped, verify that the proper breaker is being used and that no other breakers are in-line.

If Shur-Link™ is on and signal light is flashing:

- The Shur-Link™ has tripped. In order to diagnose the cause, look to see which fault LED is lit on the Shur-Link™ control module (*MAX CURRENT* or *OVER CURRENT*).
- If *MAX CURRENT* is lit, the digital display should read above 150A if the faulted channel is #1 to #4, or it will read above 100A if the faulted channel is #5. The channel LED for the faulted channel (*MOTOR 1*, *MOTOR 2*, etc.) will be flashing to indicate which channel caused the fault. There is either a short-circuit in the wiring for that channel, or the motor was drawing a current that exceeds the *MAX CURRENT* limit for that channel. Inspect the wiring for damage that could cause the wires to short together or short to the chassis and verify that the motors are connected to the proper channels. The stall current of the motors must be less than the *MAX CURRENT* limits for the channel they are connected to.
- If *OVER CURRENT* is lit, the digital display will read the last current reading taken before the 15 second time limit expired for the *OVER CURRENT* limit. The channel LED for the faulted channel (*MOTOR 1*, *MOTOR 2*, etc.) will be flashing to indicate which channel caused the fault. Check to make sure the rocker switches and SMARTtransmitter® buttons were not held or stuck in the *OPEN* or *CLOSE* position and verify that the motors are connected to the proper channels. The typical run current of the motors (not the stall current) must be less than the *OVER CURRENT* limits for the channel they are connected to.

If Shur-Link™ immediately trips when you try to turn it on and signal light starts flashing:

- A short-circuit has been detected by the Shur-Link™. The digital display will read *SC1* which indicates that a possible short circuit is present. Make sure that all systems are off, or that no switches are stuck in the operating position. Once any active load has been turned off, the Shur-Link™ can be turned back on. Otherwise, inspect the wiring for damage that could cause the wires to short together or short to the chassis.

Enabling & Disabling SMARTransmitter® Channels:

The Shur-Co® SMARTransmitter® has five channels. Pressing the *Select* button toggles through these channels. Unused channels can be disabled, if desired, using the following process. This process may be skipped. Unused transmitter channels will not perform any functions.

Hold the *Select* button down for 10 seconds and the transmitter will enter *Channel Programming Mode*. Each time *Channel Programming Mode* is entered, the status of all five channels must be reset by pressing *Open/On* or *Close/Off*.

NOTE: This process will not interfere with any pre-programmed signals that may have been pre-set by the factory or dealer.

While in *Channel Programming Mode*, the programmable channel will be indicated by a solid lit LED.

NOTE: The transmitter will NOT activate any motor or the Shur-Link™ Pro while the transmitter is in *Channel Programming Mode*.

Press the *Open/On* button to enable the current channel (designated by the indicator light). Press the *Close/Off* button to disable the current channel. The indicator light will automatically jump to the next channel.

After programming all five channels, the transmitter will display the programmed channel status for all channels for three seconds. All enabled channel LEDs will be lit solid and all disabled channel LEDs will not be lit. Buttons will not function during this three-second period.

The transmitter will automatically exit *Channel Programming Mode* after three seconds and return to *Operational Mode*.

NOTE: If there is not at least one enabled channel after programming, the transmitter will not save the changes and will revert back to the previously saved channel settings.

TIP: To cancel your changes and exit *Channel Programming Mode*, close the transmitter cover.

Program SMARTransmitter® to Shur-Link™:

Shur-Co® SMARTransmitter® may not have been programmed to the Shur-Link™ at the factory or by the dealer and may need to be programmed before use. Reprogramming is necessary after replacement transmitters or the Shur-Link™ control module are installed.

Use the following method to program the Shur-Link™ to accept and respond to signals from up to five transmitters. The Shur-Link™ will not accept or respond to signals from transmitters that have not been programmed using this method.

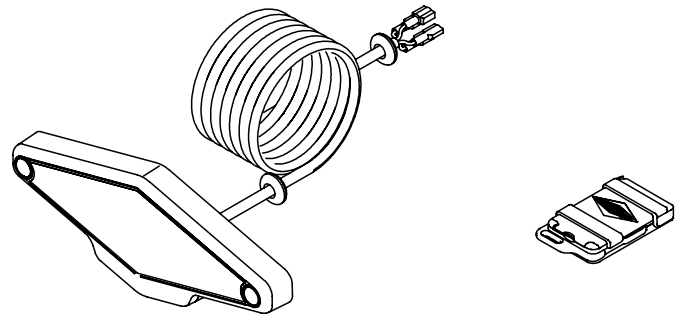

SHUR-LINK™
SIGNAL LIGHT

SMARTRANSMITTER®
(REMOTE OR TRANSMITTER)

Program SMARTransmitter® to Shur-Link™

1. Be sure the Shur-Link™ is connected to the power supply. If a battery disconnect switch is installed, make sure it is turned on.
2. Verify that the Shur-Link™ signal light is wired to the Shur-Link™ control module. The signal light must be wired to the control module for this procedure to work.
3. Turn the Shur-Link™ control module off. The Shur-Link™ will not enter *Program Mode* while the *POWER LED* is on.
4. Press and hold the *ENTER* and down-arrow (▼) buttons for about five seconds on the control module until *tr1* is displayed on the digital display.
5. The Shur-Link™ can be programmed to recognize and respond to up to five different SMARTransmitters.
6. Set the transmitter to the *Auxiliary* channel LED. A different channel on the transmitter may be used if desired.
 - 7a. **One SMARTransmitter®:** Press the *Open/On* button five times. After each transmission, the digital display on the control module will flash briefly and the transmitter number on the digital display will increment by one.
 - 7b. **Multiple SMARTransmitters:** Press the *Open/On* button at least one time for each transmitter. After each transmission, the digital display on the control module will flash briefly and the transmitter number on the digital display will increment by one. The Shur-Link™ will expect five signals, so if you are programming less than five transmitters, press the *Open/On* button on each SMARTransmitter®. On the last transmitter you are programming, press additional times. Push an *Open/On* button a total of five times to take up all five signals that the Shur-Link™ can recognize.
8. After the fifth transmission, the digital display and the Shur-Link™ signal light will flash five times. This flashing indicates that the transmitter(s) have successfully been introduced to the Shur-Link™ control module.
9. You can now turn the Shur-Link™ on and off using the Shur-Co® SMARTransmitter®.

A 
1704545 Pan Hd. Plastite Screw - #6 x 3/8"

B 
1704405 Self-Drilling Screw - #8 x 3/4"

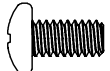
C 
1704547 Pan Hd. Machine Screw - 1/4" x 1/2"

D 
1704546 Carriage Bolt - 1/4" x 2"

E 
1700381 Cap Screw - 1/4" x 1"

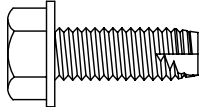
F 
1700400 Self-Tapping Screw - 3/8" x 1"

G 
1701543 Nylon Lock Nut - 1/4"

H 
1700408 Hex Nut - 1/4"

J 
1700407 Hex Nut - 3/8"

K 
1700427 Flat Washer - 1/4"

L 
1704548 Flat Washer - #12

M 
1118037 Black Plastic Washer - 1/4" x 5/8" Rd.

N 
1700434 Lock Washer - 3/8"

INSPECT ALL PARTS IN YOUR SHUR-LINK™ KIT UPON ARRIVAL

TOOLS REQUIRED FOR INSTALLATION

1. Drill
2. 9/32" Drill Bit
3. 5/16" Drill Bit
4. 11/16" Drill Bit
5. 13/32" Drill Bit
6. #2 Phillips Screwdriver
7. #2 Phillips Insert Bit
8. 3/8" Combination Wrench
9. 7/16" Combination Wrench
10. 9/16" Combination Wrench
11. Tape Measure
12. Air or Electric Impact Wrench (9/16" Socket)
13. 7/16" Socket
14. Ratchet
15. Wire Cutters
16. Ball Point Pen
17. Wire Terminal Crimper
18. 1 1/4" Drill Bit or Hole Saw
19. Knife (for cutting 6 Ga. Wire Insulation)

Item	Part #	Description
1.		Shur-Link™ Signal Light
2.	1704699	Wire Clip - 5/16"
3.	1704397	Rubber Grommet - 7/16" x 15/16"
B.	1704405	Self-Drilling Screw - #8 x 3/4"
D.	1704546	Carriage Bolt - 1/4" x 2"
G.	1701543	Nylon Lock Nut - 1/4"
H.	1700408	Hex Nut - 1/4"
K.	1700427	Flat Washer - 1/4"
M.	1118037	Black Plastic Washer - 1/4" x 5/8"

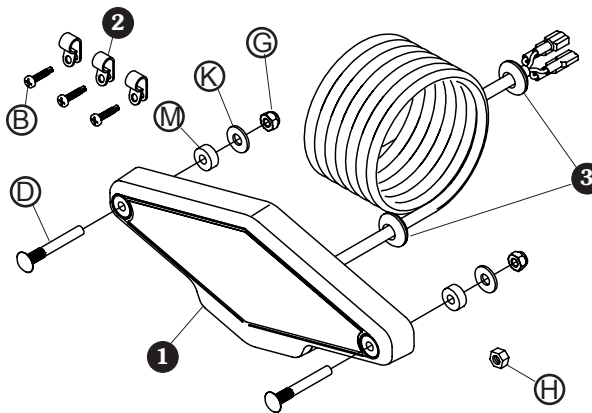

NOTE: When determining locations for signal light and control modules, keep in mind that the 8' electric cord on the signal light must connect to the control module.

STEP 1: Locate Shur-Link™ signal light where it is visible to the driver. **Recommended:** Locate signal light on side of trailer below the roll tube. Be sure roll tube does not come in contact with signal light while tarp system is operating.

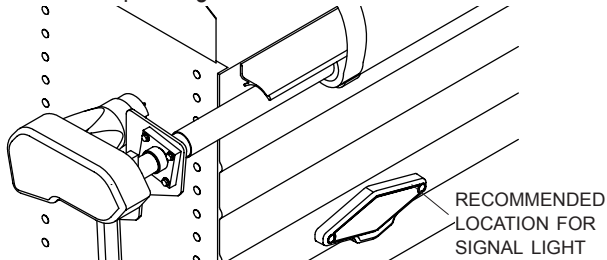

STEP 2: Mark location where wire from signal light will pass through trailer. Drill 11/16" hole.

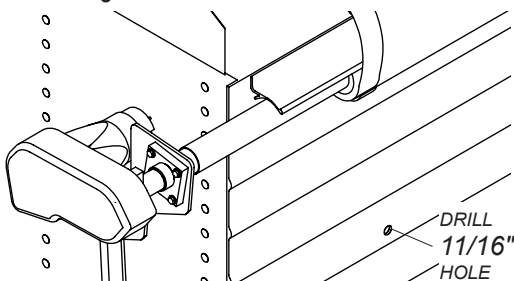

STEP 3: Feed wire through grommet, then install grommet into 11/16" hole. Align signal light flush against trailer. A second grommet is provided if control module is mounted on outside of trailer.

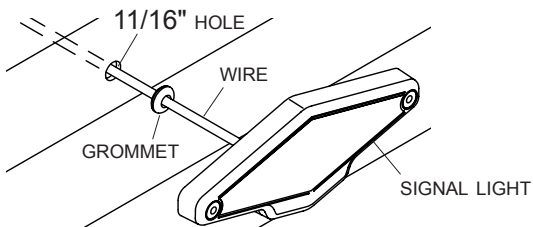

STEP 4: Using holes in signal light as a guide, mark and drill two 9/32" holes through trailer.

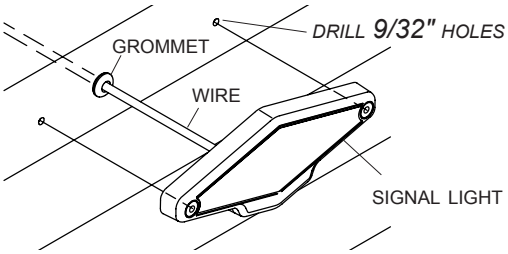

STEP 5: Insert carriage bolts **D** into holes in signal light. Place washers **K** over end of bolt. Pull carriage bolts into holes in signal light by turning nuts **H** on ends of bolts until bolt heads are flush with signal light. Discard nut **H** when finished.

NOTE: Carriage bolts are ribbed near the bolt head for a tight fit and to prevent rotation.

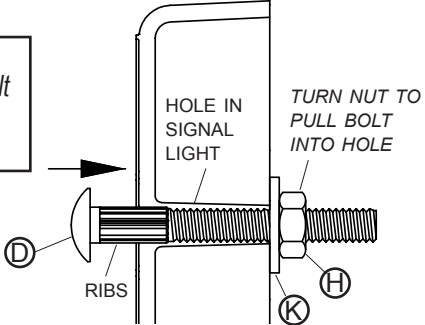

STEP 6: Fasten signal light to trailer with carriage bolts **D**, washers **K** and nuts **G**. Locate plastic washers **M** between signal light and outside of trailer skin.

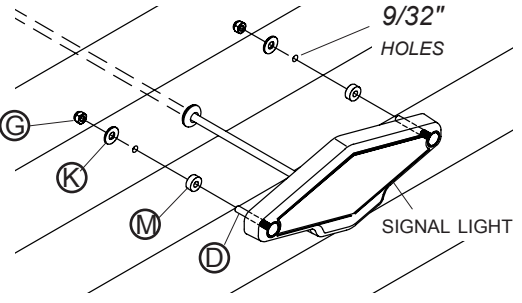

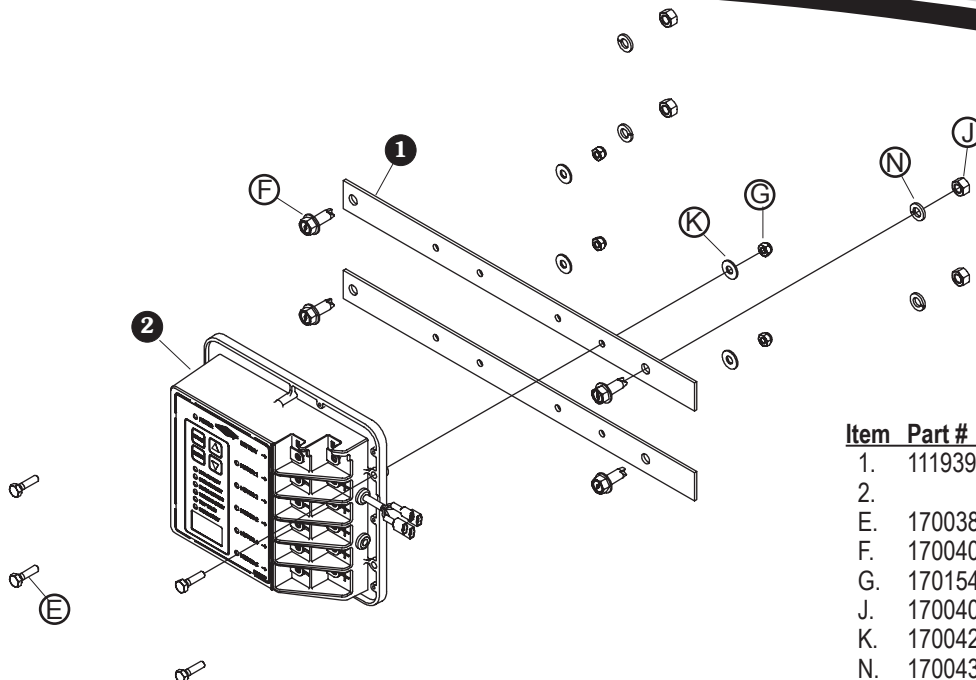

Item	Part #	Description
1.	1119395	Mounting Bar - 1 1/4" x 18"
2.		Shur-Link™ Control Module
E.	1700381	Cap Screw - 1/4" x 1"
F.	1700400	Self-Tapping Screw - 3/8" x 1"
G.	1701543	Nylon Lock Nut - 1/4"
J.	1700407	Hex Nut - 3/8"
K.	1700427	Flat Washer - 1/4"
N.	1700434	Lock Washer - 3/8"

NOTE: Existing wire may be used to wire the Shur-Link™ control module. The control module location may be determined by the accessibility of existing wire. If using existing wire, do not mount the control module until all wiring has been completed.

STEP 1: Recommended: Locate Shur-Link™ control module inside kingpin near driver side of trailer.

NOTE: If mounting the control module on the outside of the trailer, mounting bars may not be needed. Fasten control module to trailer with screws **E**, washers **K** and nuts **G**.

STEP 2: If using mounting bars, fasten mounting bars to control module with screws **E**, washers **K** and nuts **G**.

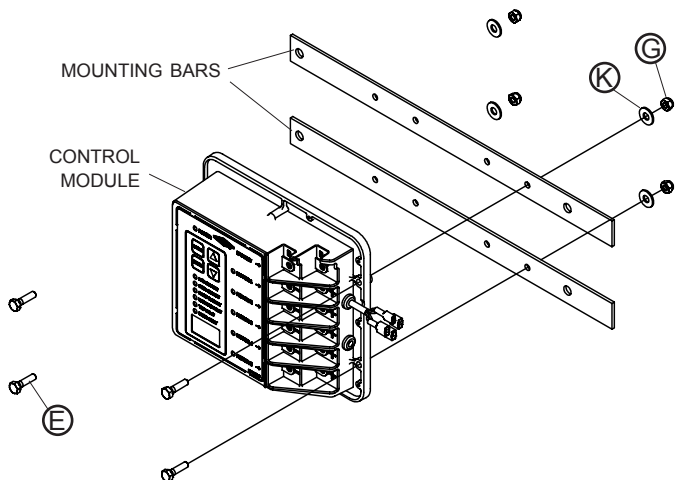

STEP 3: Using holes in mounting bars as a guide, mark and drill 5/16" holes in trailer. Use an impact wrench to fasten control module to trailer with self-tapping screws **F**, washers **N** and nuts **J**.

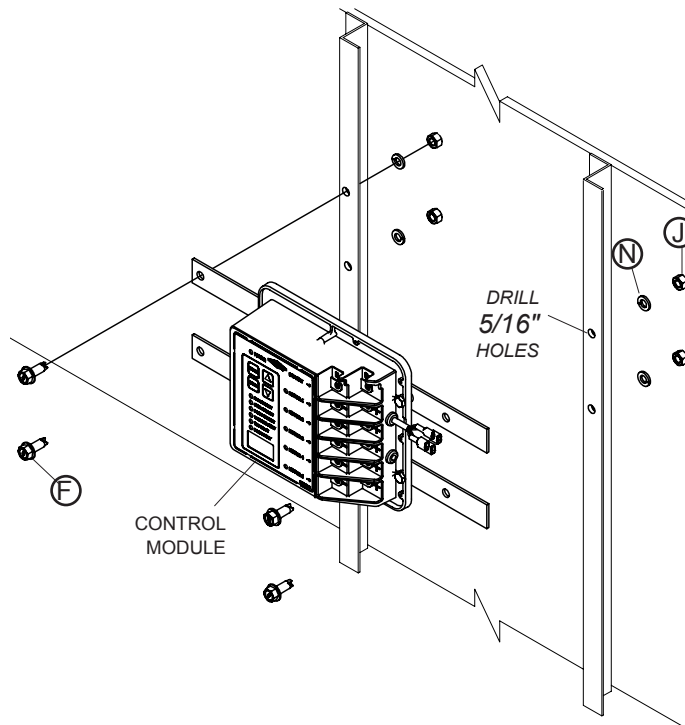

NOTE: The control module must be mounted on a vertical surface.

STEP 4: Install rubber grommets into holes in control module cover.

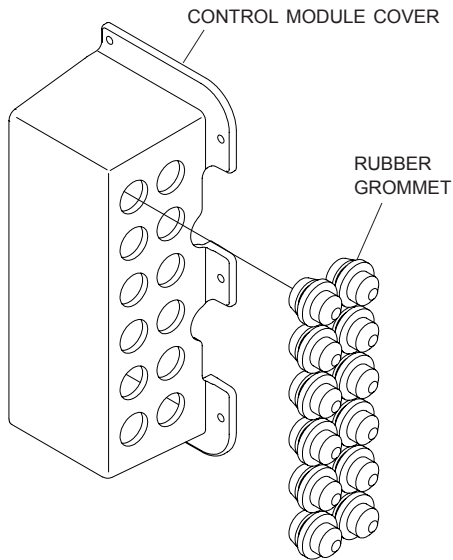

STEP 5: Pierce grommets with ballpoint pen so that terminal wires can be inserted through pierced holes.

NOTE: Only pierce grommets that will have wire routed through them.

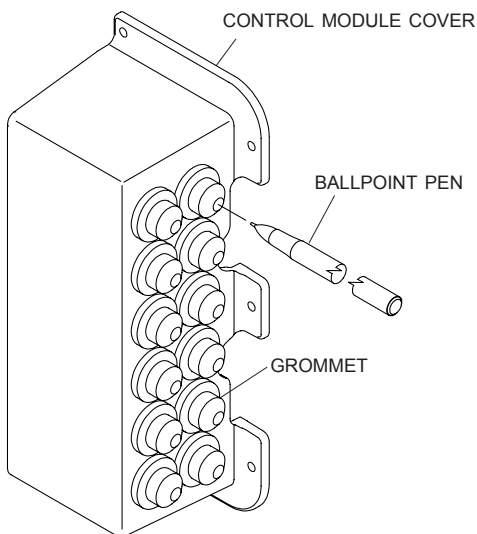

STEP 6: See *Electric Wiring* section to fasten wires to control module. Fasten cover to control module cover with screws **A**.

NOTE: Insert wires through grommets in cover before connecting wires to terminals in control module.

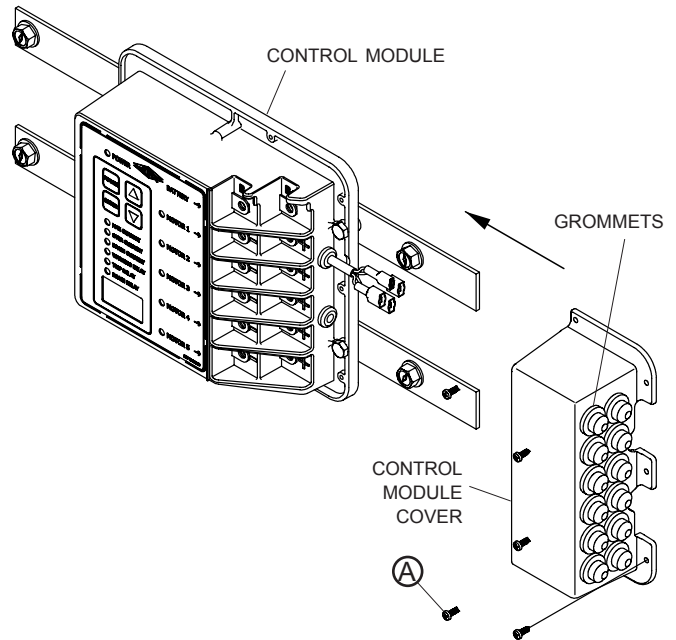

ELECTRIC WIRE NOT SHOWN FOR CLARITY

NOTE: Before connecting wires, make sure conductor plug and conductor socket are not connected. All electric power from battery must be disconnected.

Replace circuit breaker near truck battery with 50-amp circuit breaker included in Shur-Link™ Pro kit. Disconnect positive battery terminal before replacing circuit breaker.

STEP 1A: Disconnect wire from conductor socket if pre-wired. Run a new section of 6 ga. wire from conductor socket to Shur-Link™ control module.

NOTE: Connect control module to conductor socket before wiring any other components.

NOTE: When installing Shur-Link™ Pro system to existing 3500 Series or ProTrap® system, 10' of wire is provided in your kit to connect the system to power.

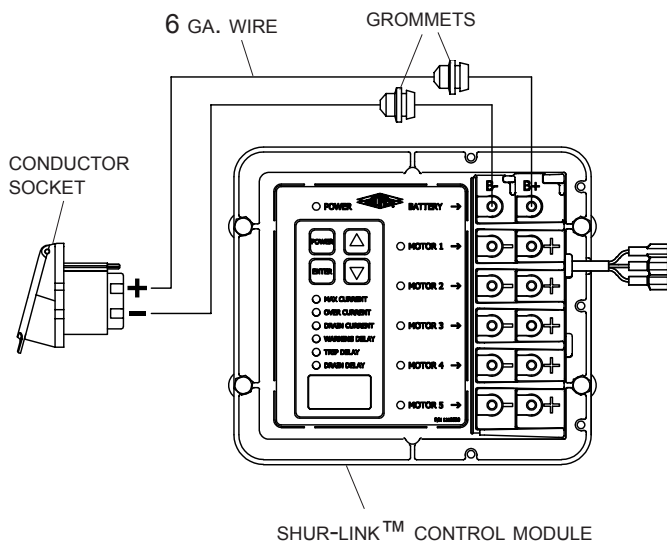

STEP 1B: Crimp two 1/4" ring terminals on control module end of wire.

Cut wires to length and strip only enough wire insulation to install ring terminals. Insert bare wire into ring terminals and crimp securely.

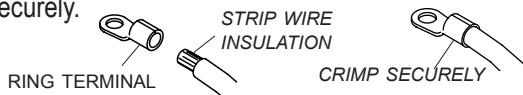

STEP 1C: Insert wires through grommets in cover before connecting wires to terminals on control module. On control module, identify terminals designated BATTERY. Insert wires through grommets in cover, then place positive wire on B+ terminal and negative wire on B- terminal. Squeeze a drop of dielectric grease into each of the 12 threaded terminals on control module and on ends of each screw C. Fasten screws C and washers L to control module.

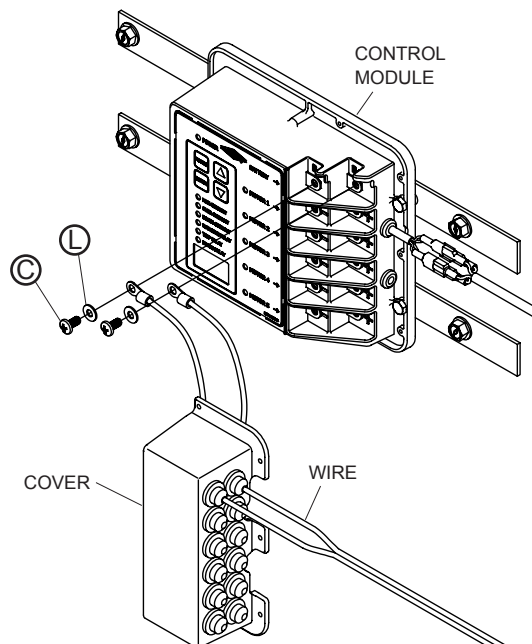

STEP 1D: Run wire from signal light to control module, routing wire as desired.

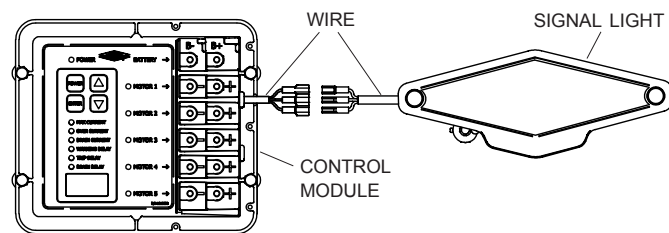

STEP 1E: Secure wire to trailer with wire clips and screws B. Connect quick disconnects, connecting white wire to white wire, red wire to red wire, black wire to black wire and blue wire to blue wire. Apply dielectric grease on each connection.

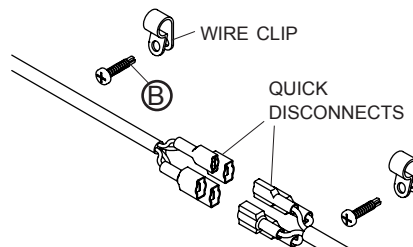

3500 SERIES ELECTRIC WIRING - GO TO PAGE 11

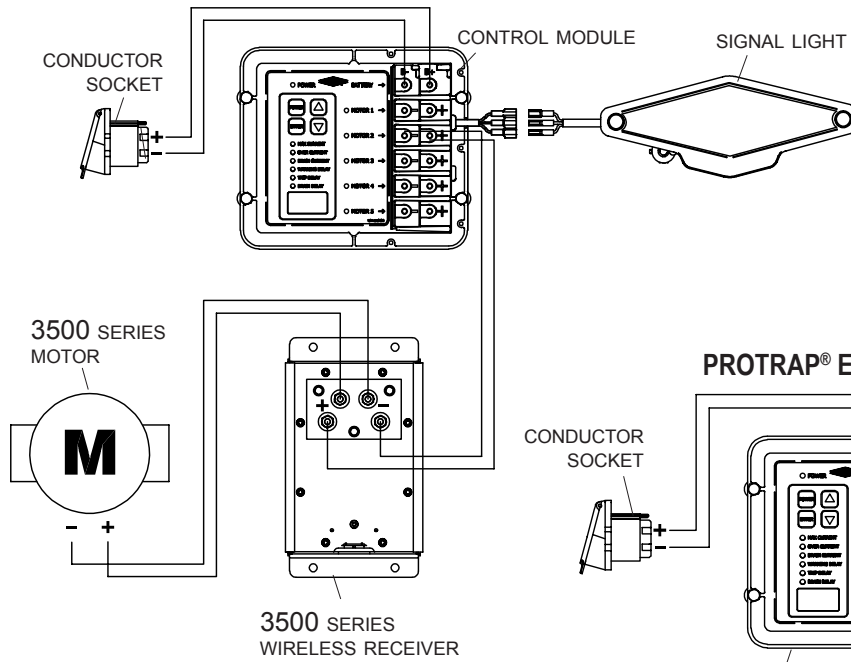

PROTRAP® ELECTRIC WIRING - GO TO PAGE 12

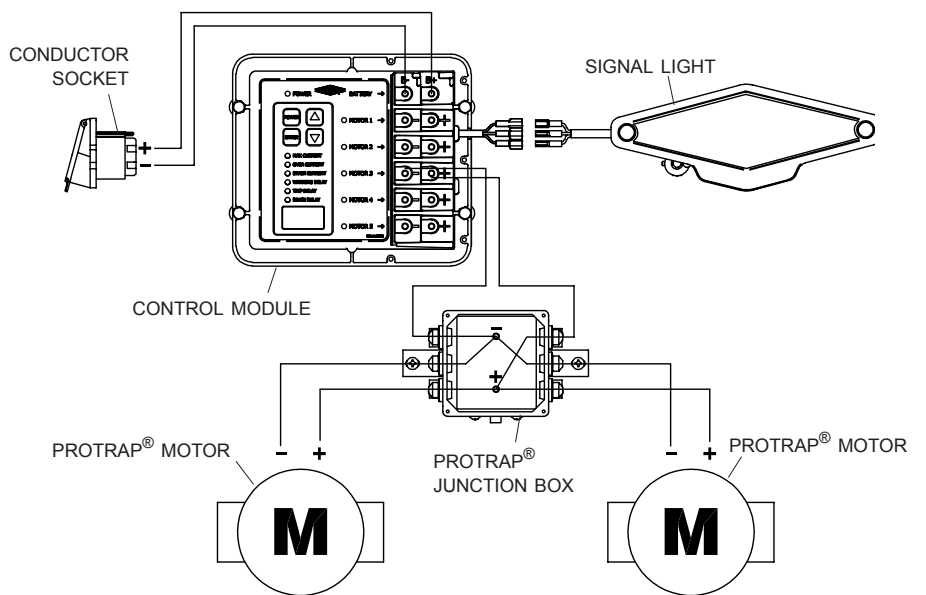

3500 SERIES & PROTRAP® ELECTRIC WIRING - GO TO PAGES 11 & 12

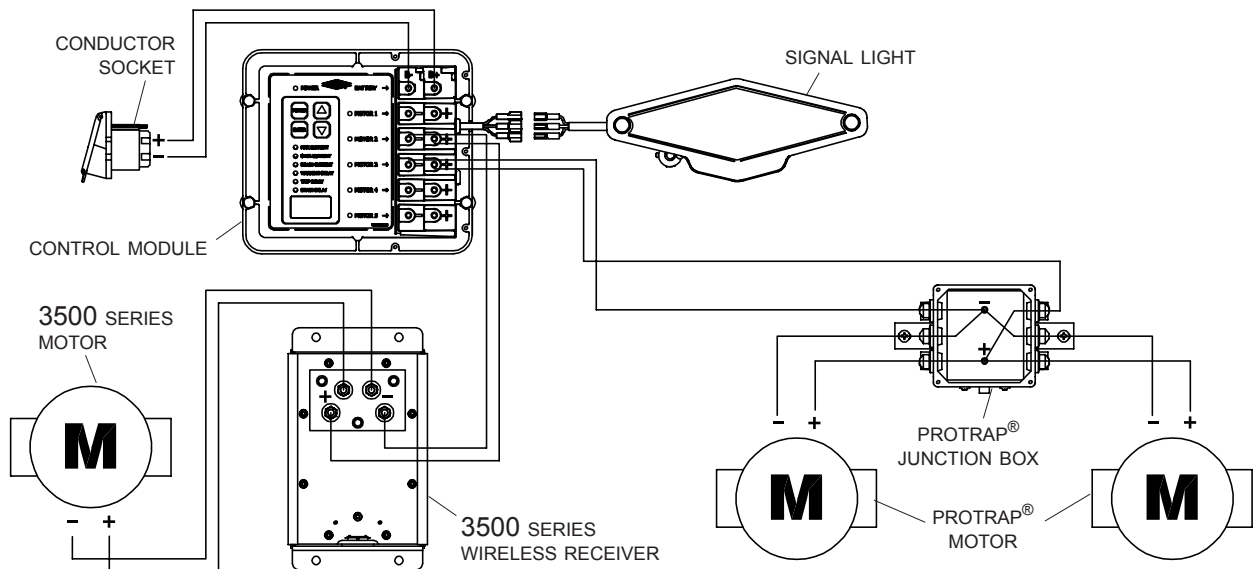

STEP 2: 3500 Series system: Install 3500 Series system on trailer as shown in 3500 Series manual.

STEP 3A: Shur-Link™ control module: Run section of 6 ga. wire from Shur-Link™ control module to 3500 wireless receiver.

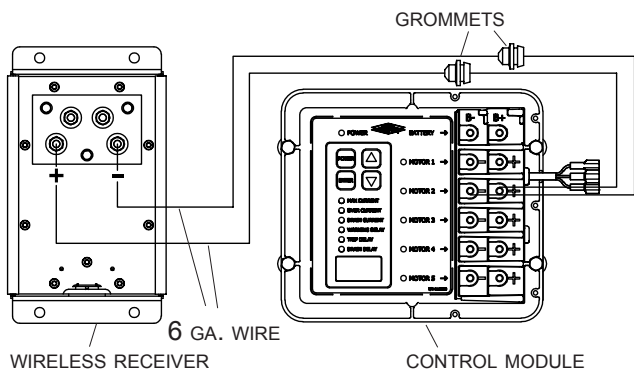

Pre-wired trailers: Check length of existing 6 ga. wire routed from 3500 Series wireless receiver to conductor socket or 3500 Series junction box. Wire must be long enough to reach Shur-Link™ control module. Disconnect wire at conductor socket or junction box and crimp 1/4" ring terminals onto wire ends if needed. Go to step 4.

STEP 3B: Insert wire ends through grommet, then through rubber boots. Crimp 1/4" ring terminals onto wire ends.

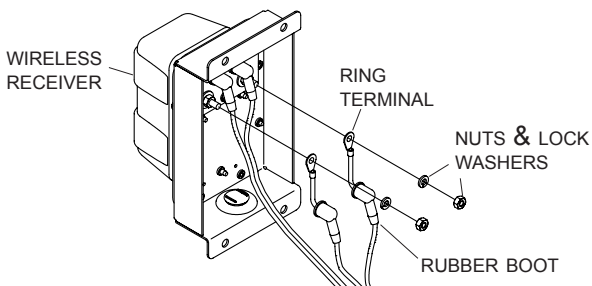

STEP 3C: Remove nuts and lock washers from lower posts on back of wireless receiver. Place positive wire on lower orange post and negative wire on lower black post. Replace lock washers and hex nuts and secure. Coat with dielectric grease and install rubber boots over ring terminals.

STEP 4: Connect other end of wire to Shur-Link™ control module. Insert wires through grommets in cover before connecting wires to terminals on control module. Place positive wire on positive (+) terminal and negative wire on negative (-) terminal, both designated MOTOR 2. Fasten wire ends to terminals with screws ① and washers ②.

NOTE: Make sure dielectric grease has been applied to all 12 threaded terminal nuts for corrosion prevention. Terminal screws should be fastened on each terminal, whether the channel is being used or not.

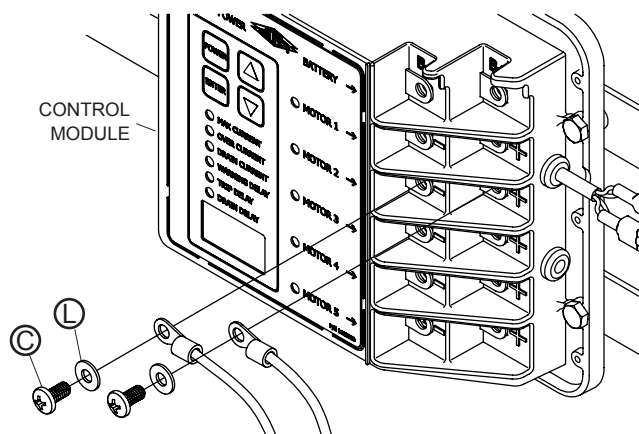

STEP 2: ProTrap® system: Install ProTrap® system on trailer as shown in ProTrap® manual.

STEP 3A: Shur-Link™ control module: Run 6 ga. wire from Shur-Link™ control module to ProTrap® junction box.

Pre-wired trailers: Check length of existing 6 ga. wire routed from ProTrap® junction box to conductor socket or 3500 Series junction box. Wire must be long enough to reach Shur-Link™ control module. Disconnect wire at conductor socket or 3500 Series junction box. Go to step 3C.

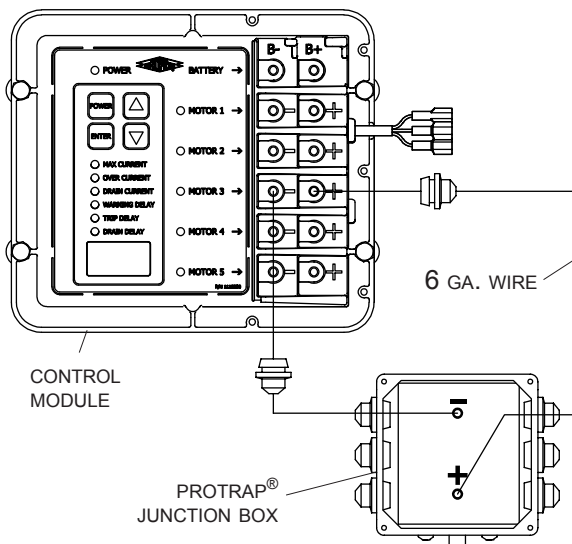

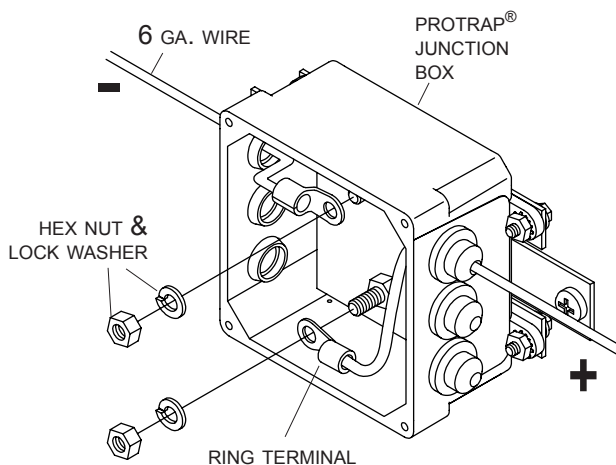

STEP 3B: Crimp 1/4" ring terminals onto wire ends if needed. Remove hex nut and lock washer from ProTrap® junction box. Place positive wire on positive post and negative wire on negative post. Secure with hex nuts and lock washers. Go to step 4.

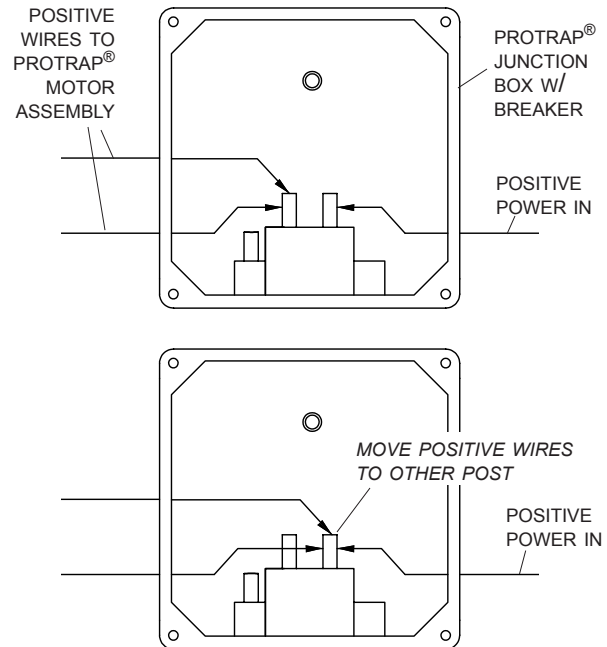

STEP 3C: If ProTrap® junction box contains a circuit breaker, disconnect circuit breaker by removing positive wire(s) running to ProTrap® motor assembly. Reconnect wire to other post on circuit breaker. This will remove circuit breaker from electric circuit.



STEP 4: Connect other end of wire to Shur-Link™ control module, routing wire as needed. Insert wires through grommets in cover before connecting wires to terminals in control module. Crimp 1/4" ring terminals onto wire ends if needed. Place positive wire on positive (+) terminal and negative wire on negative (-) terminal, both marked MOTOR 3. Fasten wire ends to terminals with screws  and washers .

NOTE: Make sure dielectric grease has been applied to all 12 threaded terminal nuts for corrosion prevention. Terminal screws should be fastened on each terminal, whether the channel is being used or not.

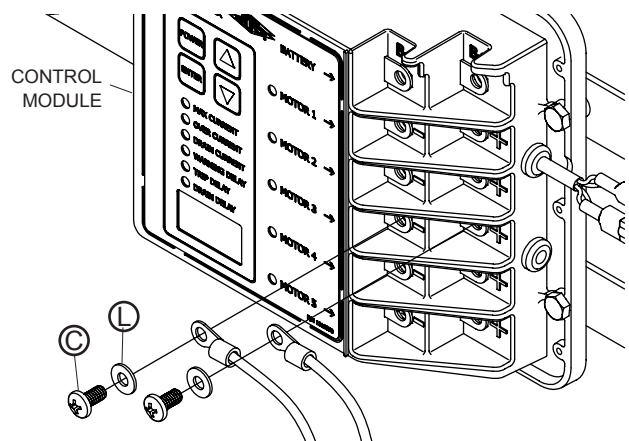

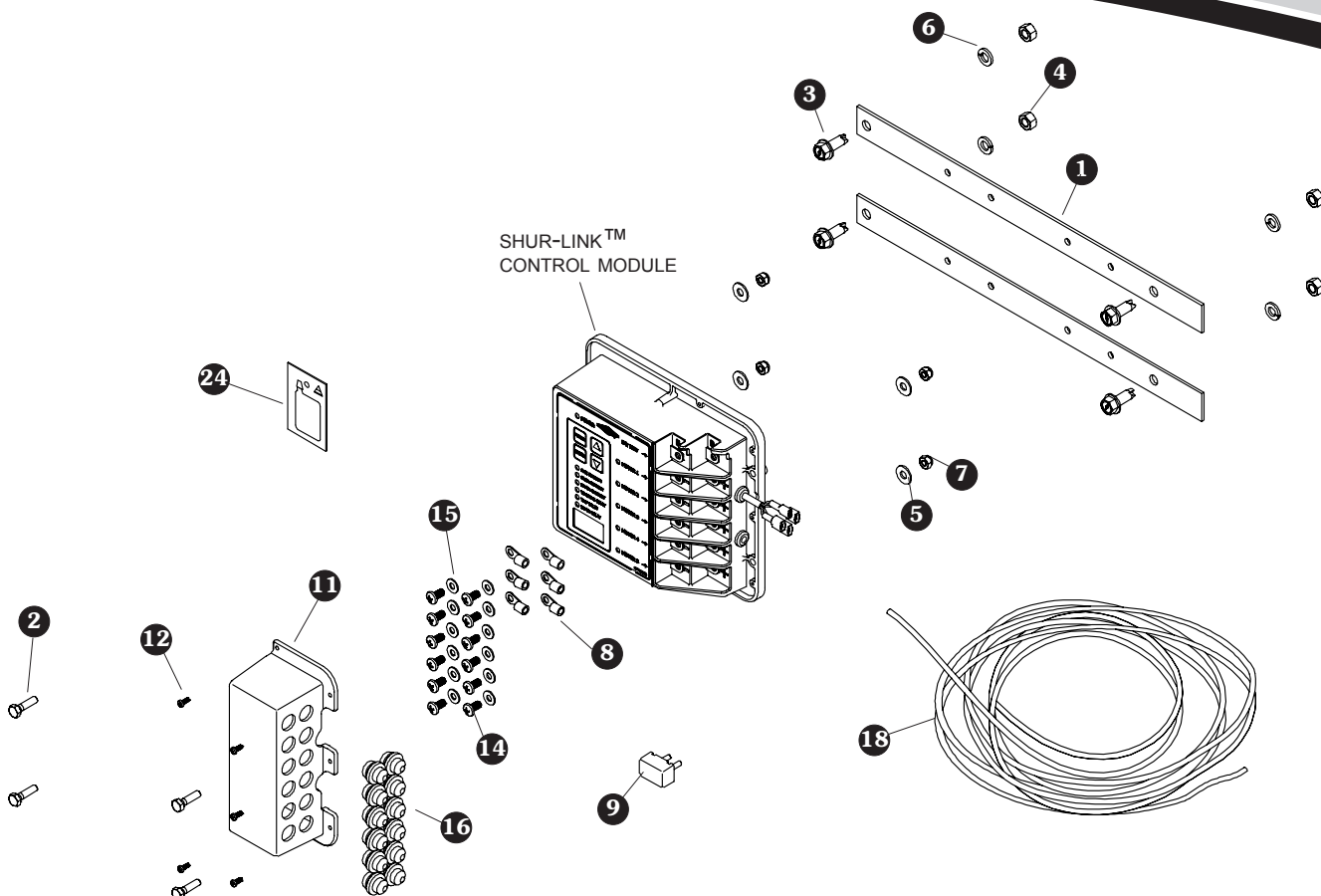

Item	Part #	Description
	1120365	Shur-Link™ Pro Upgrade Kit
	1119390	Replacement Shur-Link™ Control Module (Includes items 9, 14, 15, 24 & Control Module)
	1119391	Replacement Shur-Link™ Signal Light (Includes items 5, 7, 10, 13, 17, 19, 20, 21, 22, 23 & Signal Light)
1.	1119395	Mounting Bar - 1 1/4" x 18"
2.	1700381	Cap Screw - 1/4" x 1"
3.	1700400	Self-Tapping Screw - 3/8" x 1"
4.	1700407	Hex Nut - 3/8"
5.	1700427	Flat Washer - 1/4"
6.	1700434	Lock Washer - 3/8"
7.	1701543	Nylon Lock Nut - 1/4"
8.	1702707	Ring Terminal - 6 Ga. x 1/4" Stud
9.	1703480	50 Amp Auto-Reset Circuit Breaker
10.	1703282	Rubber Grommet - 1 1/4" x 3/16" Groove
11.	1704541	Control Module Cover
12.	1704545	Pan Hd. Plastite Screw - #6 x 3/8"
13.	1704546	Carriage Bolt - 1/4" x 2"
14.	1704547	Pan Hd. Machine Screw - 1/4" x 1/2"
15.	1704548	Flat Washer - #12
16.	1704556	Rubber Grommet - 5-10 mm - IP65
17.	1118037	Black Plastic Washer - 1/4" x 5/8"
18.	1119077	Dual Conductor Wire - 6 Ga. x 10'
19.	1703231	Cable Tie - 8"
20.	1704699	Wire Clip - 5/16"
21.	1704405	Pan Hd. Self-Drilling Screw - #8 x 3/4"
22.	1700408	Hex Nut - 1/4"
23.	1704397	Rubber Grommet - 7/16" x 15/16"
24.	1704378	Dielectric Connector Protector Grease

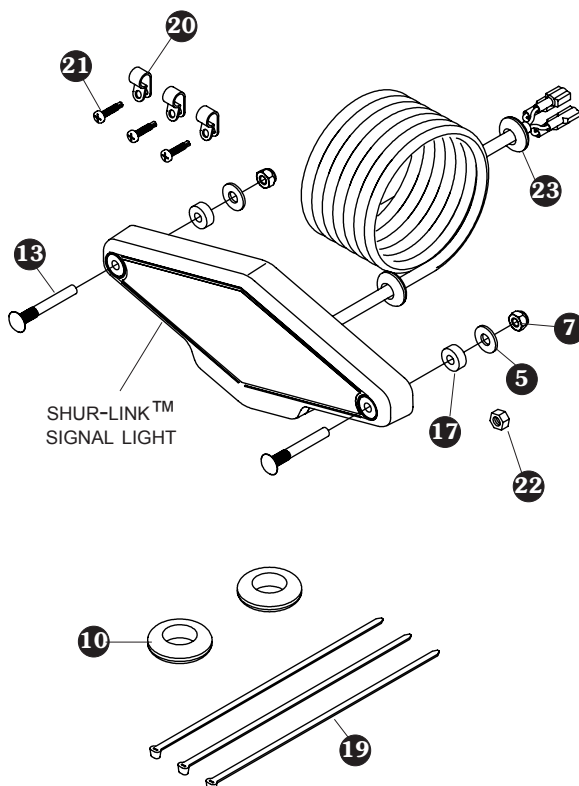

SHIPPING. All orders are shipped F.O.B. from the Shur-Co®, LLC sites listed below. There will be no full freight allowed or prepaid shipment accepted unless quoted and approved in writing prior to acceptance of the order. All shipments are made by the most reasonable means in accordance with the size and weight of the order, unless specified routing instructions are furnished by the customer. Shipments are made daily via U.P.S. and common carrier. Claims for shortages must be made within 10 days. All claims for damages or loss in transit must be made with the carrier. No collect calls will be accepted. To ensure delivery of orders, we need your full street address and phone number. When you receive your shipment, examine it carefully. Be sure all cartons listed on the delivery sheet are accounted for. Large items may be packaged separately. If a carton is damaged, open it and inspect the contents before signing for delivery. If merchandise is damaged, describe the damage on the delivery receipt. Failure on your part to document damaged or missing merchandise on the delivery receipt releases the carrier of all liability; repair or replacement will be the customer's responsibility.

WARRANTY. Shur-Co®, LLC warrants that all new products are free from defects in materials and workmanship.* This warranty is effective if products are properly installed and used for the purpose for which they were intended and applies to the original buyer only. Our obligation under this warranty is limited to repairing or, at our option, replacing any part that is returned, transportation prepaid, to Shur-Co®, LLC, Yankton, SD, if the product is, in our judgement, defective. All materials returned without prior authorization will be refused. We shall not be liable or responsible to supply or pay labor to replace any part found defective nor liable for damages of any kind or nature to person, product, property or downtime. There are no warranties for used products or products that have been repaired, altered, modified or subjected to misuse, negligence, accident or ordinary wear and tear. We will not honor claims if non-Genuine Shur-Co® parts are used.

* Certain products have specific warranties that differ from this statement, i.e. motors and electronics. Product-specific documentation is available for these items.

RETURN POLICY. All sales are final. Returns for warranty must be accompanied by a Return Merchandise Authorization number (RMA#) to ensure proper credit. Transportation charges must be prepaid on returned warranty goods. C.O.D. returns will not be accepted. Upon confirmation of deficiencies by inspection, the merchandise will be corrected and returned prepaid, or purchase price credited if still under warranty. All other returns are subject to a 15% restocking fee. Any deviations to above merchandise returns must be preapproved. All prices, product listings, sizes, weights and manufacturing details are subject to change without notice. If a return is scheduled to be picked up by Shur-Co®, LLC, no storage charges will be paid by Shur-Co®, LLC prior to pickup. We will pick up the merchandise at our earliest convenience. No person is authorized to modify the foregoing conditions of sale whatsoever.

SHUR-CO® OF SOUTH DAKOTA

Corporate HQ and Outlet Store
2309 Shur-Lok St., PO Box 713
Yankton, SD 57078-0713
Phone - 800.474.8756
Fax - 605.665.0501

SERVICE CENTERS

SHUR-CO® of NORTH DAKOTA
920 38th St. NW, Exit 66
Fargo, ND 58102
Phone - 877.868.4488
CANADA - 800.663.0000
Fax - 701.277.1283

SHUR-CO® of OHIO

1100 N. Freedom, St. Rt. 88 & 14
Ravenna, OH 44266
Phone - 866.356.0242
Fax - 330.297.5599

SHUR-CO® of TEXAS

34505 I-10 West, S. Frontage Rd.
Brookshire, TX 77423
Phone - 866.689.0039
Fax - 281.934.3311

SHUR-CO® of OKLAHOMA

1604 East US Hwy 66
El Reno, OK 73036
Phone - 866.356.0243
Fax - 405.262.3842

SHUR-CO® of COLORADO

10220 Brighton Rd., Unit #1
Henderson, CO 80640
Phone - 866.355.9173
Fax - 303.289.2298

SHUR-CO® of ILLINOIS

4350 E. Boyd Rd.
Decatur, IL 62521
Phone - 866.356.0246
Fax - 217.877.8270

SHUR-CO® of IOWA

3839 Midway Blvd.
Ft. Dodge, IA 50501
Phone - 866.356.0245
Fax - 515.576.5578

MORE QUALITY PRODUCTS FROM SHUR-CO®

- Value Series Shur-Lok®
- Super Duty Shur-Lok®
- Value Series Belt & Ratchet
- Premium Belt & Ratchet
- Shur-Lok® Junior
- Cable-Lok™ Spool Tarp
- 3500 Series Electric Shur-Lok®
- Value Series Electric Shur-Lok®
- Super Duty Electric Shur-Lok®
- SMARTrailer™ Accessories
- SMARTransmitter®
- ProTrap® Electric Hopper Door Opener
- Electric Turning Point™ Bow System
- Shur-Trak II™ Cable System
- Cover-Pro II® Cable System
- UltraSteel Arm System
- Arm-Matic™ Arm System
- Fitted & Flat Covers
- Turning Point™ Bow System
- Combine Hopper Ext. Covers
- Stock & Custom Flatbed Tarps
- Load Control Line
- Genuine Replacement Tarps
- Genuine Replacement Parts
- Solar Power Pack
- Shur-Link™ Pro

ENGINEERED TARPING SOLUTIONS

