



ENGINEERED TARPING SOLUTIONS

P/N 1120900 Rev. A

OWNER'S MANUAL



Aluminum System for Live-Bottom Trailer

READ BEFORE INSTALLING

PO BOX 713 ■ 2309 SHUR-LOK STREET ■ YANKTON, SD 57078-0713
PHONE 1-800-4-SHUR-LOK (1-800-474-8756) ■ FAX 605-665-0501
www.shurco.com

SHOP ONLINE: www.shopshurco.com

SHIPPING. All orders are shipped F.O.B. from the Shur-Co®, LLC sites listed below. There will be no full freight allowed or prepaid shipment accepted unless quoted and approved in writing prior to acceptance of the order. All shipments are made by the most reasonable means in accordance with the size and weight of the order, unless specified routing instructions are furnished by the customer. Shipments are made daily via U.P.S. and common carrier. Claims for shortages must be made within 10 days. All claims for damages or loss in transit must be made with the carrier. No collect calls will be accepted. To ensure delivery of orders, we need your full street address and phone number. When you receive your shipment, examine it carefully. Be sure all cartons listed on the delivery sheet are accounted for. Large items may be packaged separately. If a carton is damaged, open it and inspect the contents before signing for delivery. If merchandise is damaged, describe the damage on the delivery receipt. Failure on your part to document damaged or missing merchandise on the delivery receipt releases the carrier of all liability; repair or replacement will be the customer's responsibility.

WARRANTY. Shur-Co®, LLC warrants that all new products are free from defects in materials and workmanship.* This warranty is effective if products are properly installed and used for the purpose for which they were intended and applies to the original buyer only. Our obliga-

tion under this warranty is limited to repairing or, at our option, replacing any part that is returned, transportation prepaid, to Shur-Co®, LLC, Yankton, SD, if the product is, in our judgement, defective. All materials returned without prior authorization will be refused. We shall not be liable or responsible to supply or pay labor to replace any part found defective nor liable for damages of any kind or nature to person, product, property or downtime. There are no warranties for used products or products that have been repaired, altered, modified or subjected to misuse, negligence, accident or ordinary wear and tear. We will not honor claims if non-Genuine Shur-Co® parts are used.

* Certain products have specific warranties that differ from this statement, i.e. motors and electronics. Product-specific documentation is available for these items.

RETURN POLICY. All sales are final. Returns for warranty must be accompanied by a Return Merchandise Authorization number (RMA#) to ensure proper credit. Transportation charges must be prepaid on returned warranty goods. C.O.D. returns will not be accepted. Upon confirmation of deficiencies by inspection, the merchandise will be corrected and returned prepaid, or purchase price credited if still under warranty. All other returns are subject to a 15% restocking fee. Any deviations to above merchandise returns must be preapproved. All prices, product listings, sizes, weights and manufacturing details are subject to change without notice. If a return is scheduled to be picked up by Shur-Co®, LLC, no storage charges will be paid by Shur-Co®, LLC prior to pickup. We will pick up the merchandise at our earliest convenience. No person is authorized to modify the foregoing conditions of sale whatsoever.

SHUR-CO® OF SOUTH DAKOTA

Corporate HQ and Outlet Store
2309 Shur-Lok St., PO Box 713
Yankton, SD 57078-0713
Phone - 800.474.8756
Fax - 605.665.0501

SERVICE CENTERS

SHUR-CO® of NORTH DAKOTA
920 38th St. NW, Exit 66
 Fargo, ND 58102
 Phone - 877.868.4488
 CANADA - 800.663.0000
 Fax - 701.277.1283

SHUR-CO® of OHIO

1100 N. Freedom, St. Rt. 88 & 14
Ravenna, OH 44266
Phone - 866.356.0242
Fax - 330.297.5599

SHUR-CO® of TEXAS

34505 I-10 West, S. Frontage Rd.
Brookshire, TX 77423
Phone - 866.689.0039
Fax - 281.934.3311

SHUR-CO® of OKLAHOMA

1604 East US Hwy 66
El Reno, OK 73036
Phone - 866.356.0243
Fax - 405.262.3842

SHUR-CO® of COLORADO

10220 Brighton Rd., Unit #1
Henderson, CO 80640
Phone - 866.356.9173
Fax - 303.289.2298

SHUR-CO® of ILLINOIS

4350 E. Boyd Rd.
Decatur, IL 62521
Phone - 866.356.0246
Fax - 217.877.8270

SHUR-CO® of IOWA

3839 Midway Blvd.
Ft. Dodge, IA 50501
Phone - 866.356.0245
Fax - 515.576.5578

MESSAGE TO OWNERS

Thank you for buying this tarping system from Shur-Co® We appreciate your confidence in our products. Please read and thoroughly understand this manual before installing and/or operating this system.

Pay particular attention to important safety and operating instructions, as well as warnings and cautions. The hazard symbol ⚠ is used to alert users to potentially hazardous conditions and is followed by caution, warning or danger messages.

Failure to READ AND FOLLOW INSTRUCTIONS could result in failure of your tarping system and/or personal injury. Your trailer requirements may, however, call for minor variations to these instructions.

Please inspect your tarping system periodically. Repair or replace worn or damaged parts to your system.

QUESTIONS? CALL OUR HELP LINE:

1-866-748-7435

MON-FRI 8 AM-5 PM CENTRAL TIME

SAFETY

We at Shur-Co® are concerned with your safety and the safety of all those operating this system. Therefore, we have provided safety decals at various locations on your tarping system. Keep decals as clean as possible at all times. Replace any decal that has become worn or damaged, painted over or otherwise difficult to read. Replacement decals are available through Shur-Co® dealers.

SAFETY INSTRUCTIONS

- 1. Always wear safety glasses during installation and operation.
- 2. Stay clear of moving parts.
- 3. No other use of this system is authorized, except as designed.

RUST PREVENTION


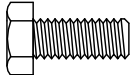


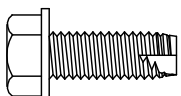
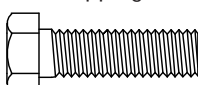
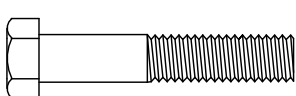
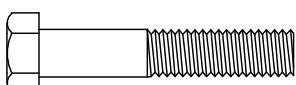
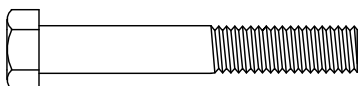
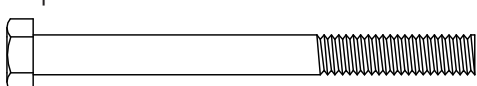
To prevent rust, paint all exposed metal, such as weld seams and/or metal exposed by grinding or cutting, with corrosion-resistant paint.

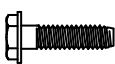






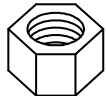
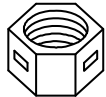
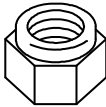
TABLE OF CONTENTS



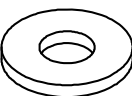
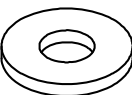
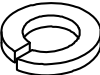
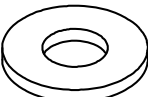
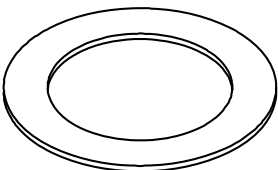
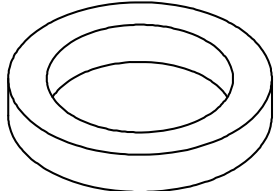
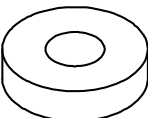
- Hardware Identification..... 1
- Front Pivot Bracket/Pivot Pin Installation..... 2
- Front Flex Arm & Electric Motor Installation 3-4
- Rear Mounting Beam & Pivot Bracket Installation 5
- Rear Flex Arm Installation - Top Hinge 6-7
- Rear Flex Arm Installation - Side Hinge..... 8-9
- Roll Tube Extension Installation - Top Hinge 10-12
- Roll Tube Extension Installation - Side Hinge..... 13-15
- Electric Mounting & Wiring 16-20
- Wireless SMARTransmitter® Programming & Operating 21
- Program Wireless SMARTransmitter® to Receiver 22
- Change from Electric to Manual Power 23
- Replacement Parts 24-27
- Troubleshooting Guide 28

TOOLS REQUIRED

- 1. Welder
- 2. Hammer
- 3. Center Punch or Transfer Punch
- 4. #3 Phillips Insert Bit
- 5. Air or Electric Impact Wrench (9/16" deep socket)
- 6. 7/16" deep socket
- 7. 3/8" Combination Wrench
- 8. 9/16" Combination Wrench
- 9. 1/2" Combination Wrench
- 10. 1/8" Hex Wrench Long T-Handle
- 11. 3/16" Hex Wrench Long T-Handle (recommended)
- 12. 5/16" Drill Bit (for 3/8" self-tapping screws)
- 13. 11/32" Drill Bit
- 14. 13/32" Drill Bit
- 15. 3/8" Drill
- 16. 1 1/8" Hole Saw
- 17. 2" Hole Saw (if bracket for conductor socket is not used)
- 18. Standard/Flathead Screwdriver
- 19. #2 Phillips Screwdriver
- 20. Utility Knife
- 21. Ratchet
- 22. Hack Saw (metal cutter)
- 23. Pliers
- 24. Snap Ring Pliers
- 25. Wire Cutters
- 26. Grinder
- 27. Tape Measure

- A**  1700381 Cap Screw - 1/4" x 1"
- B**  1701045 Cap Screw - 5/16" x 3/4"
- C**  1702926 Cap Screw - 5/16" x 7/8"
- D**  1703487 Cap Screw - 5/16" x 1 1/2"
- E**  1700400 Self-Tapping Screw - 3/8" x 1"
- F**  1702891 Cap Screw - 3/8" x 1 1/4"
- G**  1704264 Cap Screw - 3/8" x 2"
- H**  1704057 Cap Screw - 3/8" x 2"
- J**  1702573 Cap Screw - 3/8" x 2 1/2"
- K**  1201022 Cap Screw - 5/16" x 3 1/2"

- L**  1704367 Cap Screw - #10 x 3/4"
- M**  1700403 Self-Tapping Screw - 1/4" x 3/4"
- N**  1704338 Self-Tapping Screw - 1/4" x 1"
- O**  1700408 Hex Nut - 1/4"
- P**  1701543 Nylon Lock Nut - 1/4"
- Q**  1700411 Hex Nut - 5/16"
- R**  1700419 Nylon Lock Nut - 5/16"
- S**  1700407 Hex Nut - 3/8"
- T**  1700418 Centerlock Nut - 3/8"
- U**  1701580 Nylon Lock Nut - 3/8"

- V**  1700436 Lock Washer - 1/4"
- W**  1700427 Flat Washer - 1/4"
- X**  1700428 Flat Washer - 5/16"
- Y**  1201237 Flat Washer - 5/16" SS
- Z**  1700434 Lock Washer - 3/8"
- a**  1700429 Flat Washer - 3/8"
- b**  1702890 Flat Washer - 1 1/4"
- c**  1118318 Spacer Washer - 1/4" x 1.81" x 1.28"
- d**  1120291 Pivot Bracket Washer

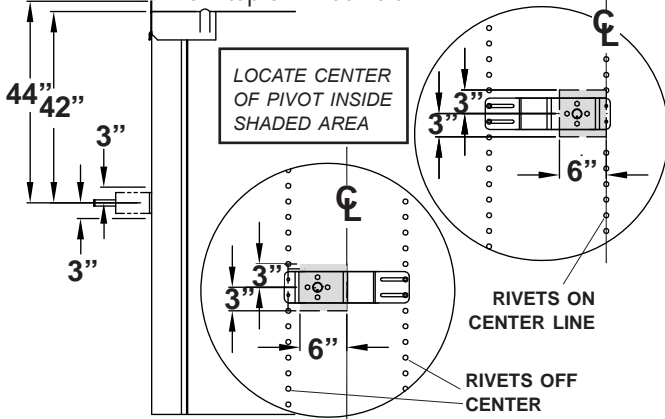
Inspect all parts in your 4500 Series electric kit upon arrival.

NOTE: Use lock washers and nuts with self-tapping screws whenever possible. A minimum material thickness of 3/16" is required in order to use self-tapping screws without lock washers and nuts. Drill 13/32" holes if lock washers and nuts are used. Drill 5/16" holes if lock washers and nuts are not used.

NOTE: Read entire section before drilling holes. Determine if rivets on front of trailer are centered or off center.

FRONT OF TRAILER

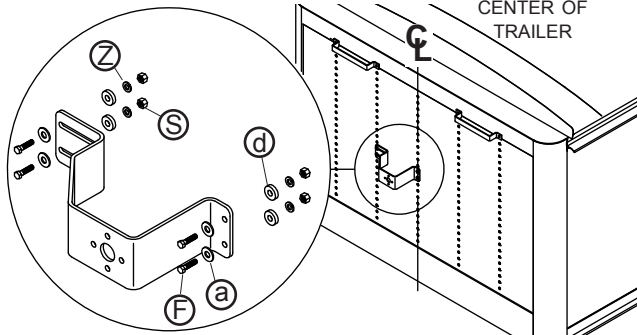
STEP 1: Locate front pivot mount bracket on passenger side of trailer so that center of pivot lies within shaded area shown below. Measure 42" down from top of cap or 44" from top of windshield.



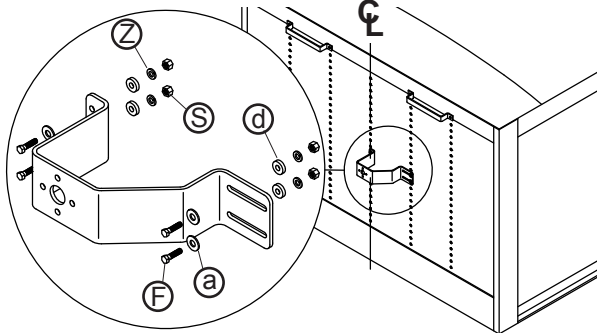
NOTE: Mount front pivot bracket into support braces on trailer if possible. If bracket cannot be mounted into support braces, reinforce mounting area with backer plate for adequate support. Before drilling any holes, make sure flex arm will have a clear pathway to operate.

STEP 2: Place pivot mount brackets on trailer in orientation shown below. Using brackets as a guide, mark mounting hole locations.

RIVETS/CORRUGATIONS ON CENTER



RIVETS/CORRUGATION OFF CENTER

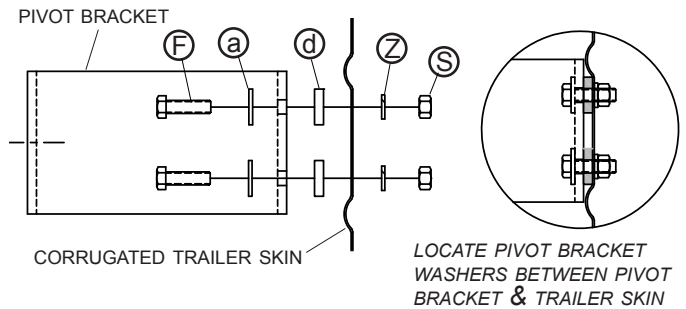


STEP 3: Remove rivets and mount brackets into rivet holes. If this is not possible, drill 13/32" holes in trailer. Fasten with 3/8" x 1 1/4" cap screws, flat washers, lock washers and nuts.

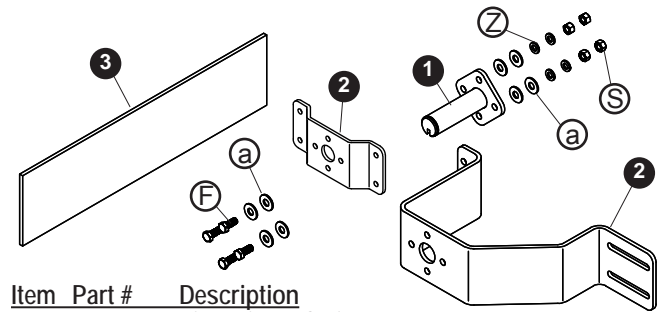
HORIZONTALLY CORRUGATED TRAILERS

NOTE: Use pivot bracket washers only when horizontal corrugation on trailer skin prevents bracket from contacting skin.

STEP 3: If installing pivot bracket or pivot mount bracket on horizontally corrugated trailer skin, center bracket between corrugations and use brackets as a guide to mark hole locations. Mark and drill 13/32" holes in trailer and fasten with 3/8" x 1 1/4" cap screws, flat washers, lock washers, pivot bracket washers and nuts. Locate pivot bracket washers between pivot bracket and trailer skin as shown.

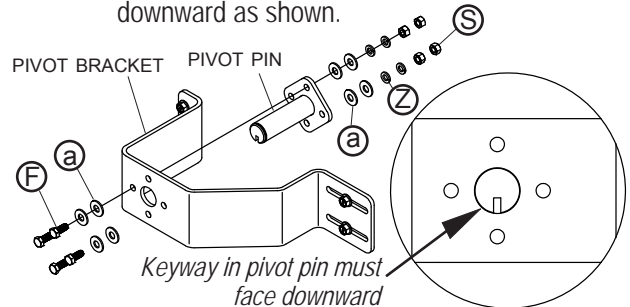


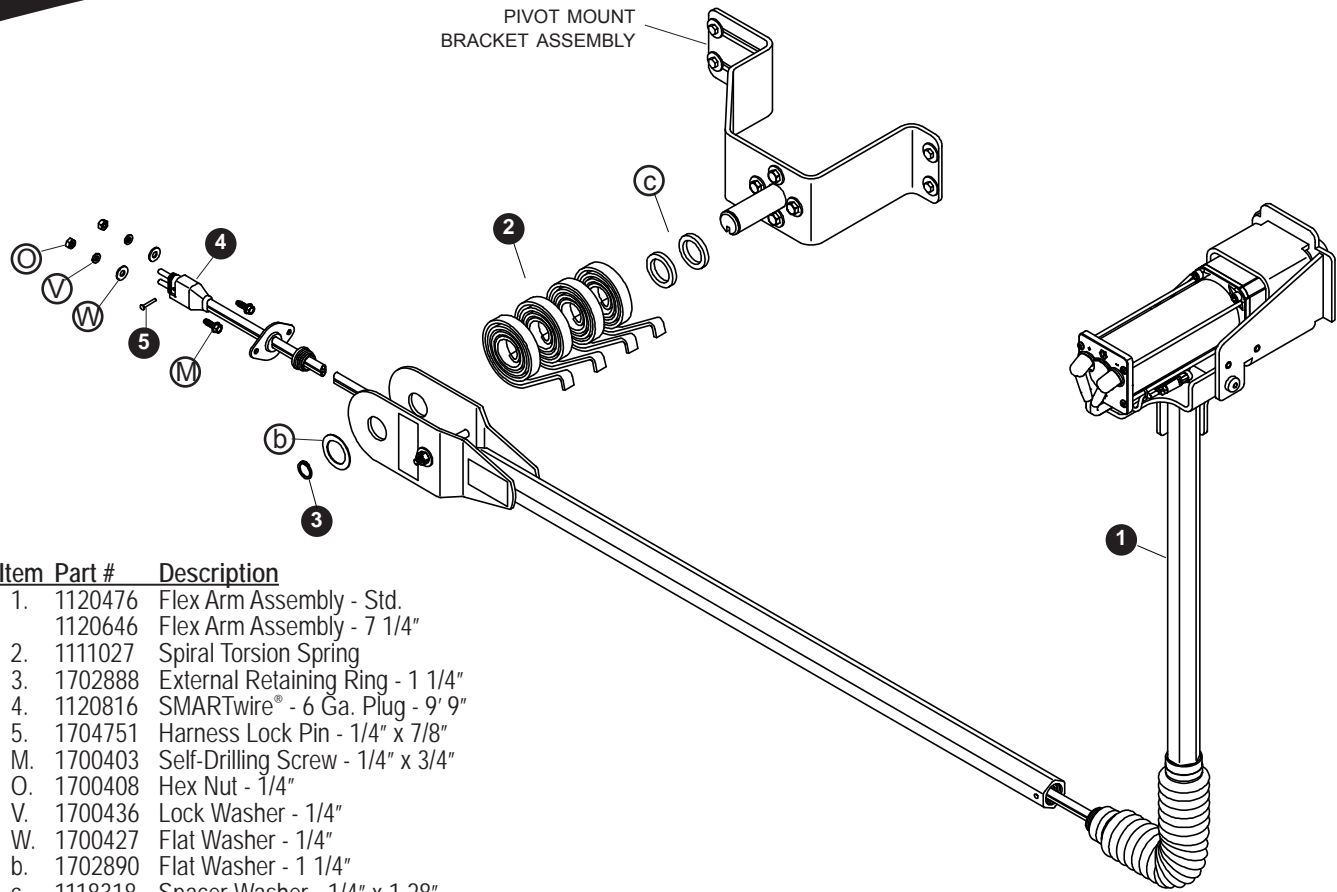
PIVOT PIN INSTALLATION



Item	Part #	Description
1.	1116920	Pivot Pin - 4 Spring
2.	1116919	Vertical Pivot Mount Bracket - 7 1/4" Standoff
	1117927	Vertical Pivot Mount Bracket - 12 1/4" Standoff
	1117767	Pivot Mount Bracket - 1 1/4"
3.	1120361	Pivot Backer Plate - 5" x 16"
	1120418	Pivot Backer Plate - 5" x 20"
F.	1702891	Cap Screw - 3/8" x 1 1/4"
S.	1700407	Hex Nut - 3/8"
Z.	1700434	Lock Washer - 3/8"
a.	1700429	Flat Washer - 3/8"

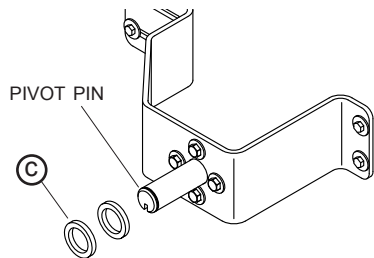
STEP 1: Fasten pivot pin to pivot bracket with keyway facing downward as shown.



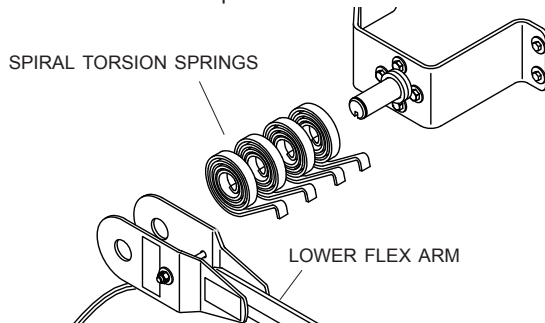


Item	Part #	Description
1.	1120476	Flex Arm Assembly - Std.
	1120646	Flex Arm Assembly - 7 1/4"
2.	1111027	Spiral Torsion Spring
3.	1702888	External Retaining Ring - 1 1/4"
4.	1120816	SMARTwire® - 6 Ga. Plug - 9' 9"
5.	1704751	Harness Lock Pin - 1/4" x 7/8"
M.	1700403	Self-Drilling Screw - 1/4" x 3/4"
O.	1700408	Hex Nut - 1/4"
V.	1700436	Lock Washer - 1/4"
W.	1700427	Flat Washer - 1/4"
b.	1702890	Flat Washer - 1 1/4"
c.	1118318	Spacer Washer - 1/4" x 1.28"

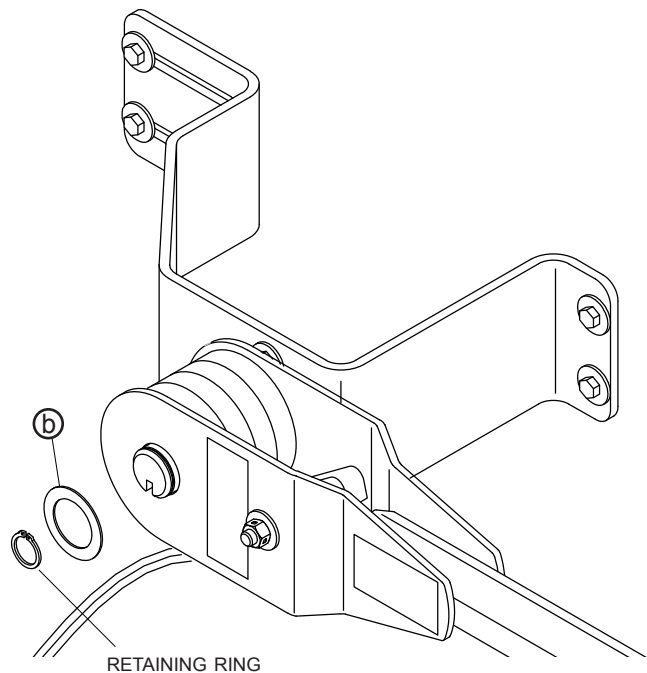
STEP 1: Assemble spacer washers onto pivot pin.



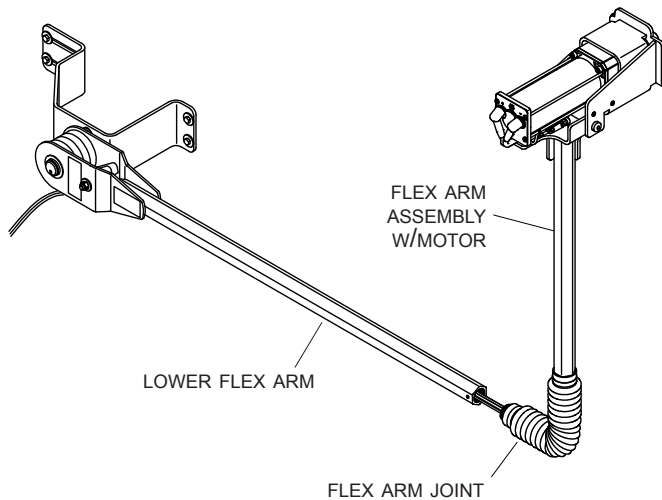
STEP 2: Assemble spiral torsion springs and lower flex arm onto pivot pin. Hook springs over 3/8" x 3 1/2" cap screw and spacer tube.



STEP 3: Secure with 1 1/4" flat washer and retaining ring.



STEP 4: Thread flex arm joint into lower flex arm. Hand tighten only.

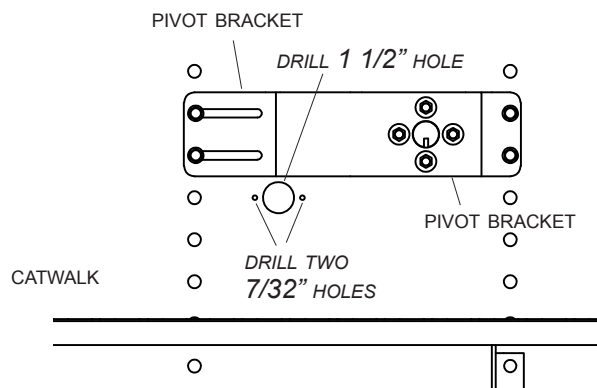


NOTE: Motor assembly on upper flex arm must face toward trailer as shown.

CAUTION
Do not twist wire when threading flex arm joint into lower flex arm.

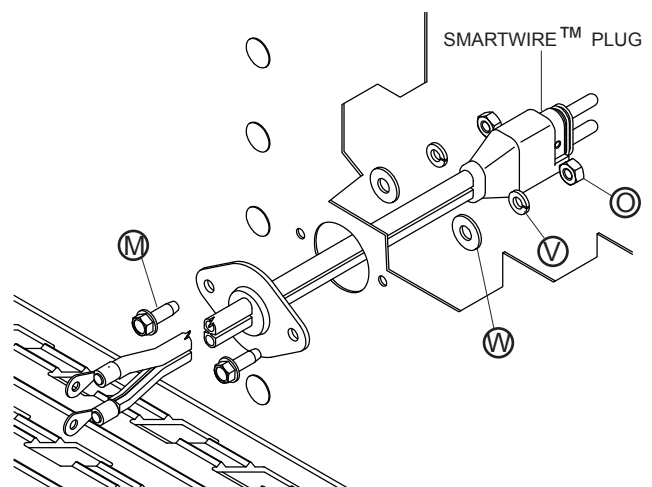
NOTE: Wire lengths are predetermined. Before installing SMARTwire™ components, review and confirm wire routing so wires will reach components with ample room for connection.

STEP 5: Measure 11" horizontally from center line of trailer and 1" down from lower edge of pivot bracket. Mark and drill 1 1/2" hole through trailer skin.



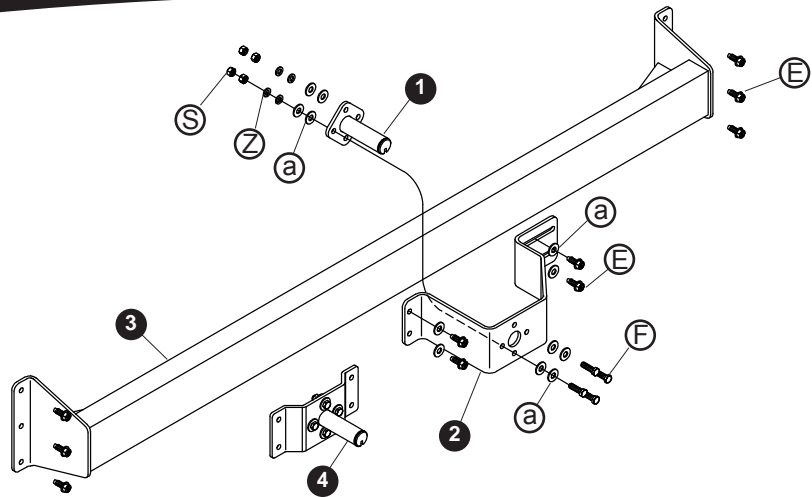
STEP 6: Align adapter plug with 1 1/2" hole. Using plug as a guide, mark and drill two 7/32" holes as shown.

STEP 7: Fasten adapter plug to front of trailer with 1/4" x 3/4" cap screws, lock washers and nuts.



Item	Part #	Description
1.	1116920	Pivot Pin - 4 Spring
2.	1116919	Vertical Pivot Mount Bracket
	1117767	Low-Profile Pivot Mount Bracket
3.	*	Mounting Beam
4.	1117816	Pivot Bracket - Side Hinge
E.	1700400	Self-Tapping Screw - 3/8" x 1"
F.	1702891	Cap Screw - 3/8" x 1 1/4"
S.	1700407	Hex Nut - 3/8"
Z.	1700434	Lock Washer - 3/8"
a.	1700429	Flat Washer - 3/8"

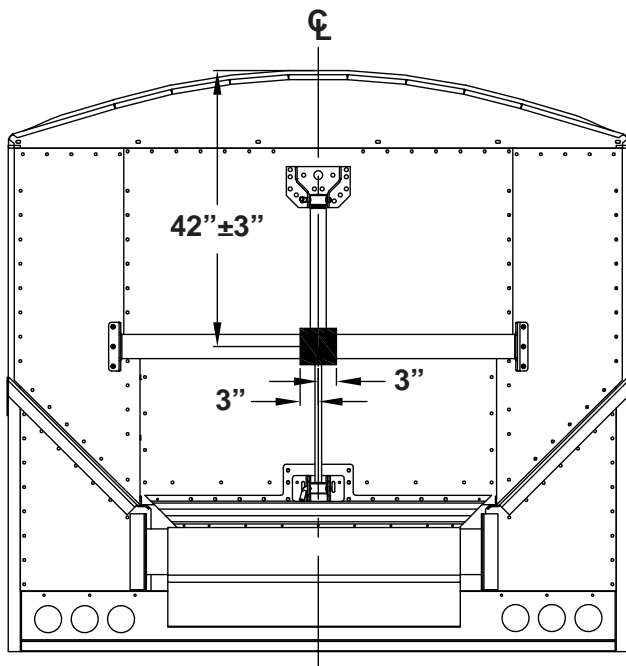
*Specify size



NOTE: Fasten rear mounting beam to structural door only. DO NOT mount beam to door skin. Tarping system will fail if beam is mounted to door skin.

Before drilling any holes, make sure flex arm will have a clear pathway to operate. Read entire section before drilling.

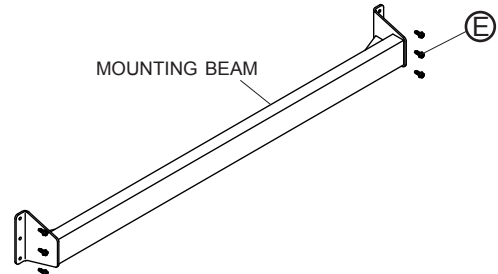
STEP 1: Locate mounting beam so that center of mounting beam lies within shaded area shown.



STEP 2: Place mounting beam on trailer as shown. Using beam as a guide, determine mounting hole locations.

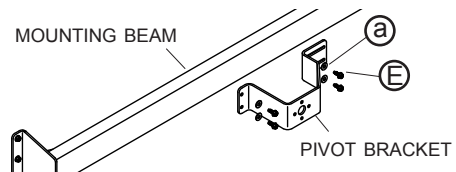
NOTE: On trailers with a knife gate, mounting beam must be centered from left to right. Verify that bolt locations will not interfere with operation of knife gate or knife gate track.

STEP 3: Remove rivets and fasten mounting beam into rivet holes. If this is not possible, drill 5/16" holes in trailer. Fasten with 3/8" x 1" self-tapping screws.

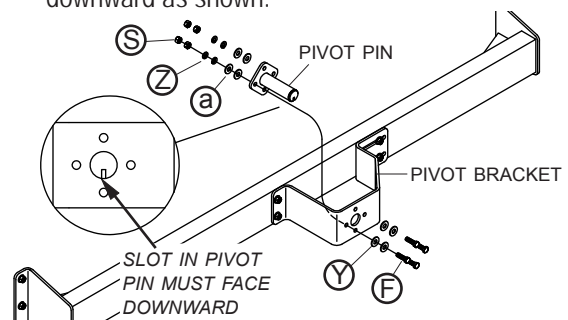


STEP 4: Center pivot bracket vertically on mounting beam. Move pivot bracket from left to right until pivot pin falls in shaded area shown in step 1. Using holes in pivot bracket as a guide, mark and drill 5/16" holes. Fasten pivot bracket to beam with 3/8" x 1" self-tapping screws and washers.

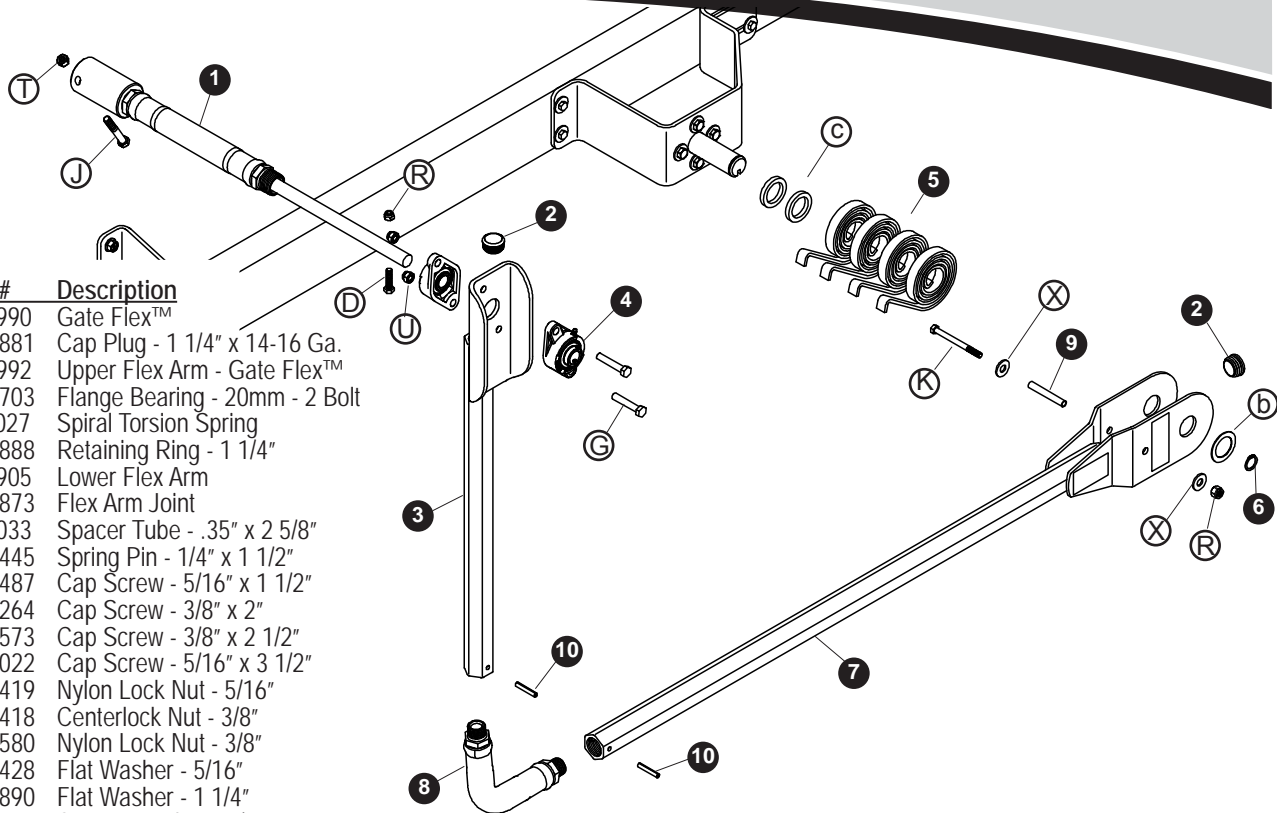
NOTE: If using the optional low-profile pivot mount bracket, complete step 5, then step 4.



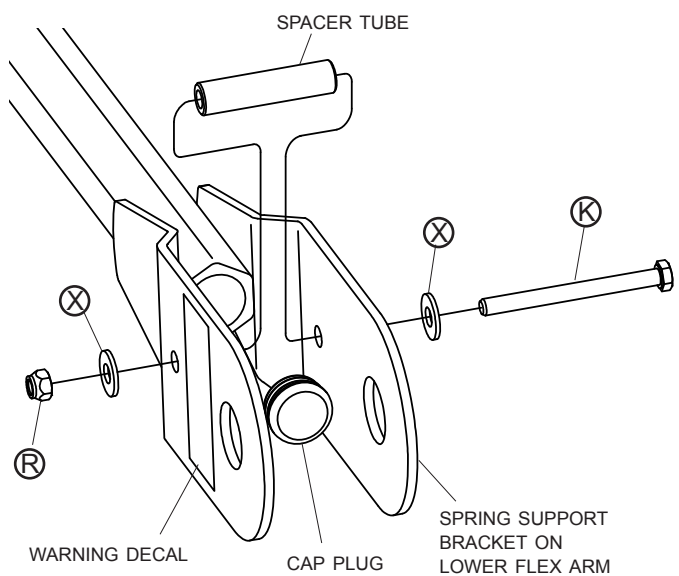
STEP 5: Fasten pivot pin to pivot bracket with keyway facing downward as shown.



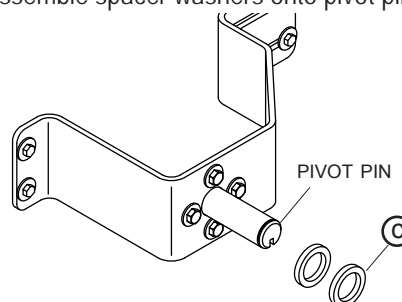
Item	Part #	Description
1.	1116990	Gate Flex™
2.	1703881	Cap Plug - 1 1/4" x 14-16 Ga.
3.	1116992	Upper Flex Arm - Gate Flex™
4.	1704703	Flange Bearing - 20mm - 2 Bolt
5.	1111027	Spiral Torsion Spring
6.	1702888	Retaining Ring - 1 1/4"
7.	1116905	Lower Flex Arm
8.	1703873	Flex Arm Joint
9.	1117033	Spacer Tube - .35" x 2 5/8"
10.	1700445	Spring Pin - 1/4" x 1 1/2"
D.	1703487	Cap Screw - 5/16" x 1 1/2"
G.	1704264	Cap Screw - 3/8" x 2"
J.	1702573	Cap Screw - 3/8" x 2 1/2"
K.	1201022	Cap Screw - 5/16" x 3 1/2"
R.	1700419	Nylon Lock Nut - 5/16"
T.	1700418	Centerlock Nut - 3/8"
U.	1701580	Nylon Lock Nut - 3/8"
X.	1700428	Flat Washer - 5/16"
b.	1702890	Flat Washer - 1 1/4"
c.	1118318	Spacer Washer - 1/4" x 1.81"



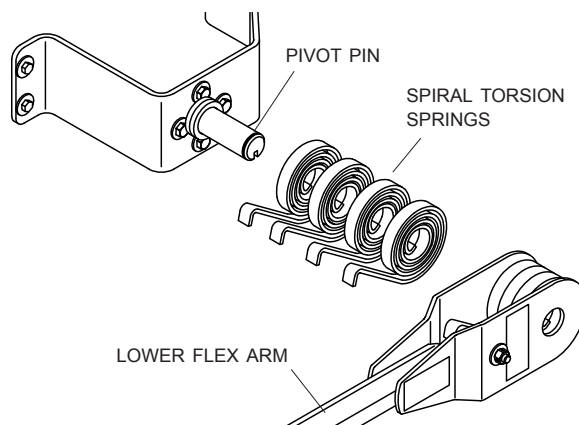
STEP 1: Install cap plug on lower flex arm. Fasten spacer tube into spring support bracket on lower flex arm with 5/16" x 3 1/2" cap screw, two flat washers and nylon lock nut.



STEP 2: Assemble spacer washers onto pivot pin.

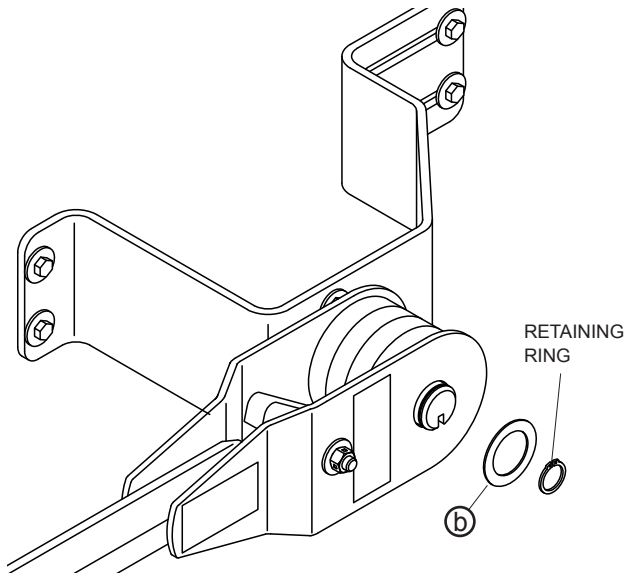


STEP 3: Assemble spiral torsion springs and lower flex arm onto pivot pin. Hook springs over 5/16" x 3 1/2" cap screw and spacer tube.

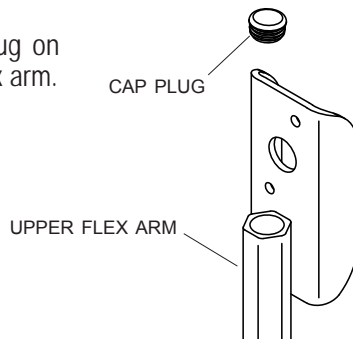


NOTE: Insert cap screw through flex arm so that head of screw will be on inside of assembly (toward the trailer). Warning label must be in plain view on outside of assembly.

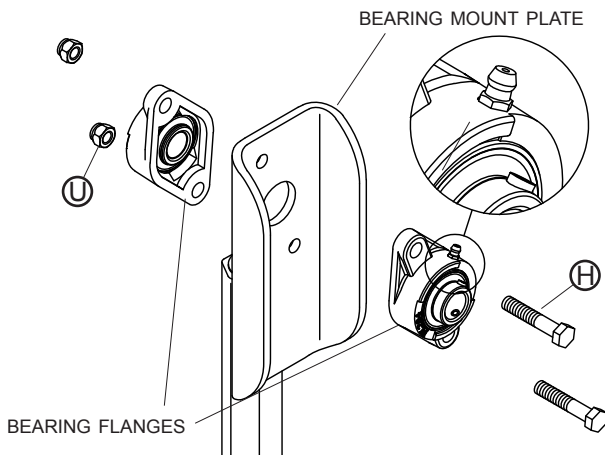
STEP 4: Secure with 1 1/4" flat washer and retaining ring.



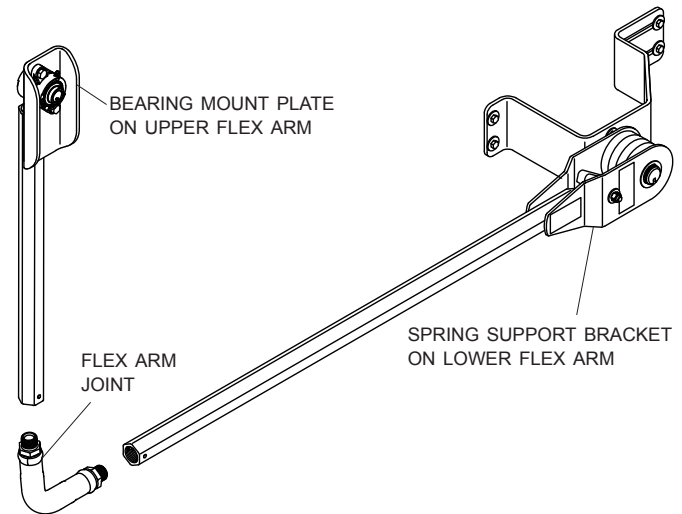
STEP 5: Install cap plug on rear upper flex arm.



STEP 6: Fasten flange bearing to bearing mount plate with 3/8" x 2" cap screws and lock nuts as shown.



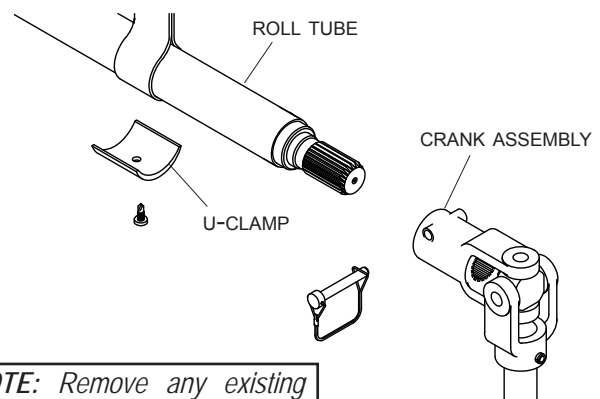
STEP 7: Thread flex arm joint into lower flex arm, then into upper flex arm. Tighten threads, aligning bearing mount plate on upper flex arm parallel to spring support bracket on lower flex arm as shown.



CAUTION

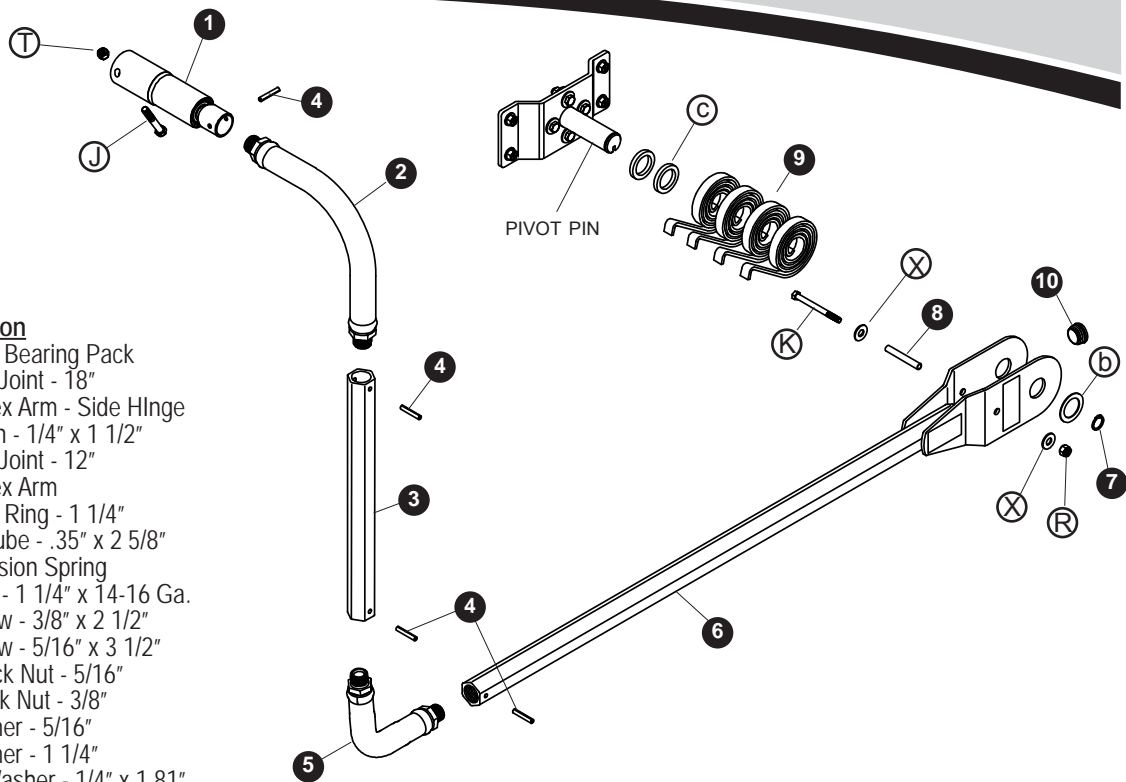
Do not open or close tarp without U-joint securely fastened to splined shaft with wire lock pin. Failure to do so could result in injury.

STEP 8: Roll tarp closed over box with roll tube hanging below latchplate. Remove crank assembly and U-clamps from roll tube.

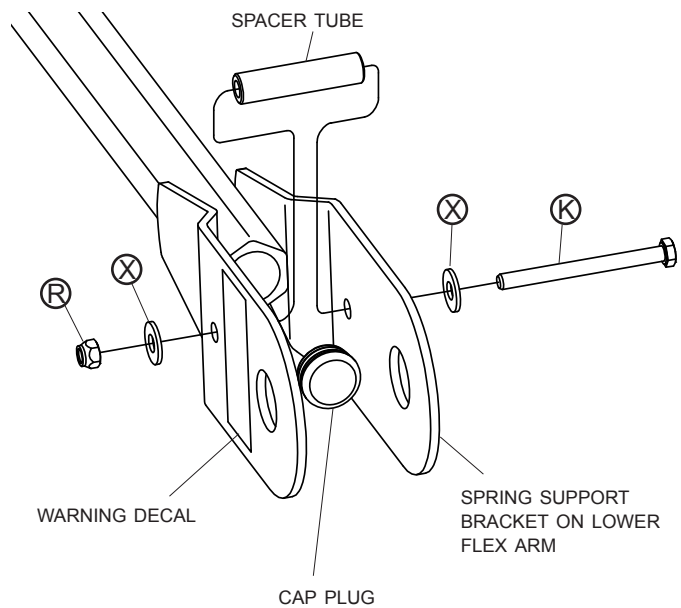


NOTE: Remove any existing returns, such as cable return, bungee return, etc.

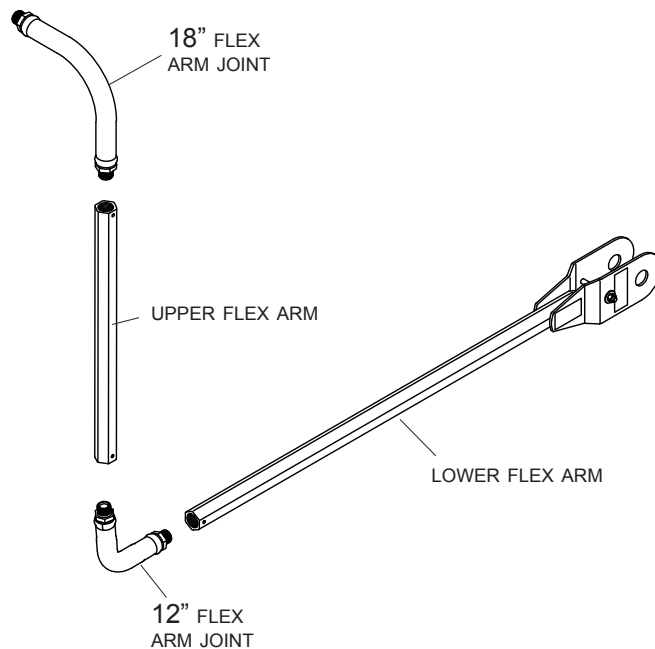
Item	Part #	Description
1.	1117777	Roll Tube Bearing Pack
2.	1704048	Flex Arm Joint - 18"
3.	1117768	Upper Flex Arm - Side Hlnge
4.	1700445	Spring Pin - 1/4" x 1 1/2"
5.	1703873	Flex Arm Joint - 12"
6.	1116905	Lower Flex Arm
7.	1702888	Retaining Ring - 1 1/4"
8.	1117033	Spacer Tube - .35" x 2 5/8"
9.	1111027	Spiral Torsion Spring
10.	1703881	Cap Plug - 1 1/4" x 14-16 Ga.
J.	1702573	Cap Screw - 3/8" x 2 1/2"
K.	1201022	Cap Screw - 5/16" x 3 1/2"
R.	1700419	Nylon Lock Nut - 5/16"
T.	1700418	Centerlock Nut - 3/8"
X.	1700428	Flat Washer - 5/16"
b.	1702890	Flat Washer - 1 1/4"
c.	1118318	Spacer Washer - 1/4" x 1.81"



STEP 1: Install cap plug on lower flex arm. Fasten spacer tube into spring support bracket on lower flex arm with 5/16" x 3 1/2" cap screw, two flat washers and nylon lock nut.

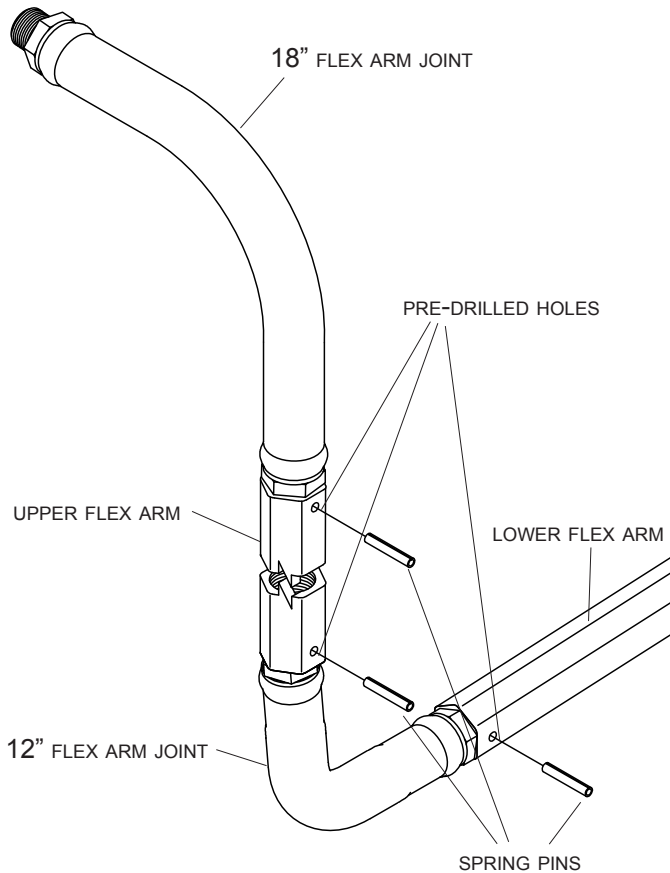


STEP 2: Fasten lower flex arm to one end of 12" flex arm joint. Fasten upper flex arm to other end of flex arm joint. Fasten 18" upper flex arm joint to open end of upper flex arm.

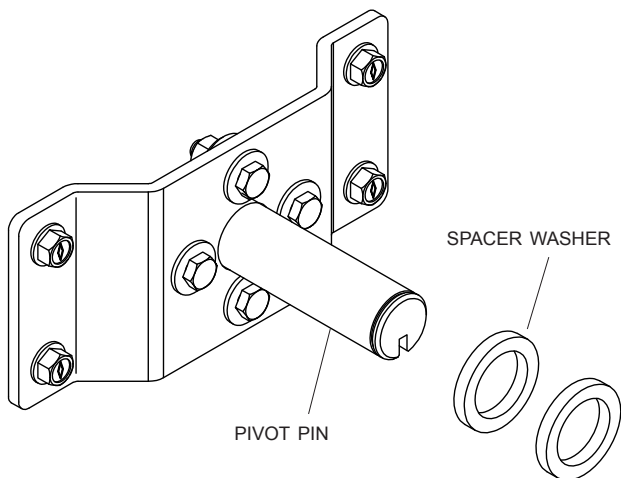


NOTE: Insert cap screw through flex arm so that head of screw will be on inside of assembly (toward the trailer). Warning label must be in plain view on outside of assembly.

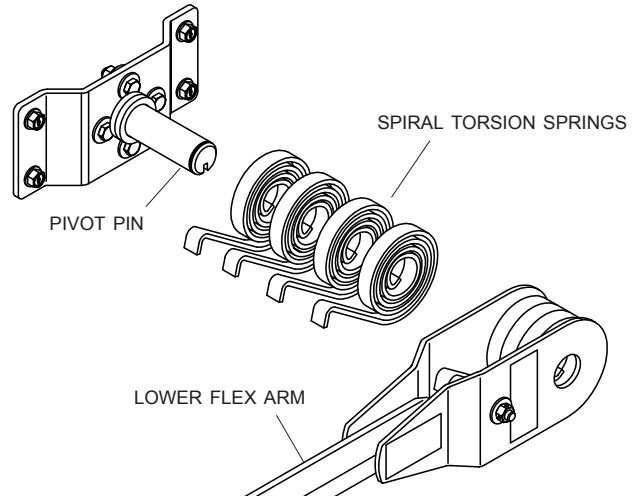
STEP 3: Drill 1/4" holes through flex arm joints at pre-drilled holes in upper and lower flex arms. Install 1/4" x 1 1/2" spring pins into holes.



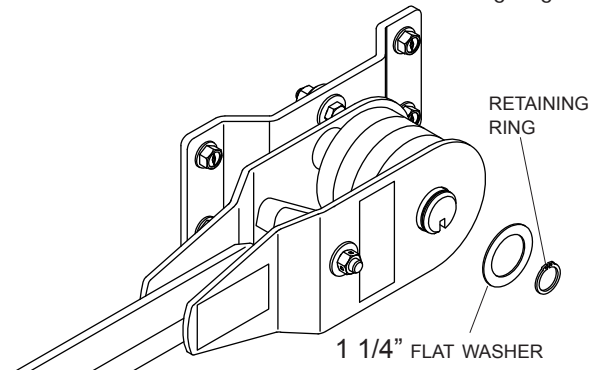
STEP 4: Assemble spacer washers onto pivot pin.



STEP 5: Assemble spiral torsion springs and lower flex arm onto pivot pin. Hook springs over 5/16" x 3 1/2" cap screw and spacer tube.



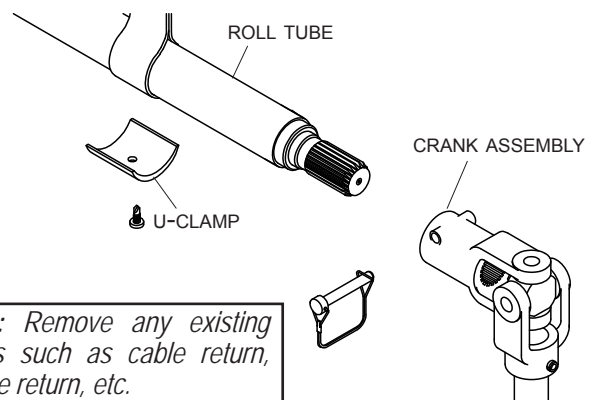
STEP 6: Secure with 1 1/4" flat washer and retaining ring.



CAUTION

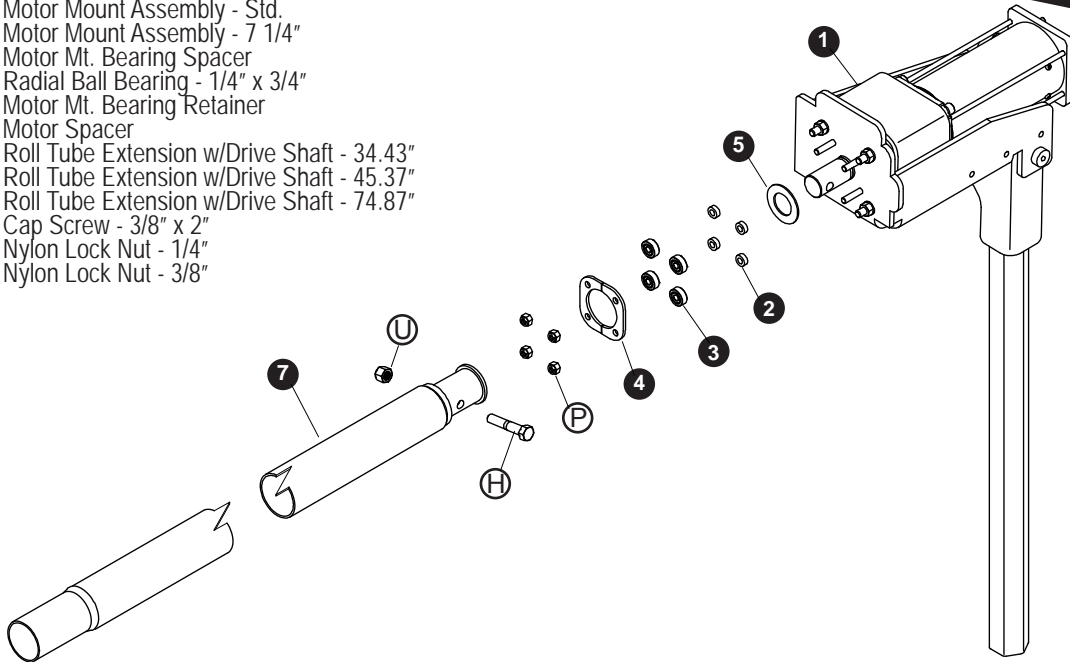
Do not open or close tarp without U-joint securely fastened to splined shaft with wire lock pin. Failure to do so could result in injury.

STEP 7: Roll tarp closed over box with roll tube hanging below latchplate. Remove crank assembly and U-clamps from roll tube.



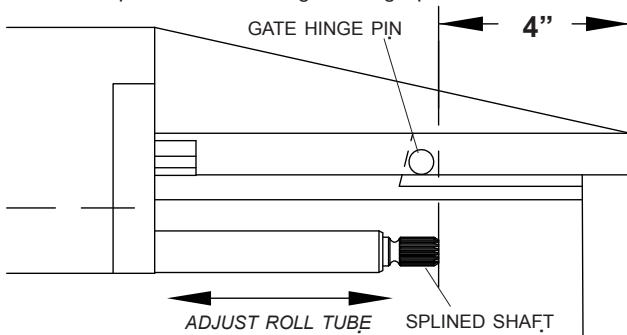
NOTE: Remove any existing returns such as cable return, bungee return, etc.

Item	Part #	Description
1.	1120766	Motor Mount Assembly - Std.
	1120781	Motor Mount Assembly - 7 1/4"
2.	1120680	Motor Mt. Bearing Spacer
3.	1704736	Radial Ball Bearing - 1/4" x 3/4"
4.	1120681	Motor Mt. Bearing Retainer
5.	1120679	Motor Spacer
7.	1120697	Roll Tube Extension w/Drive Shaft - 34.43"
	1120698	Roll Tube Extension w/Drive Shaft - 45.37"
	1120699	Roll Tube Extension w/Drive Shaft - 74.87"
H.	1704057	Cap Screw - 3/8" x 2"
P.	1701543	Nylon Lock Nut - 1/4"
U.	1701580	Nylon Lock Nut - 3/8"



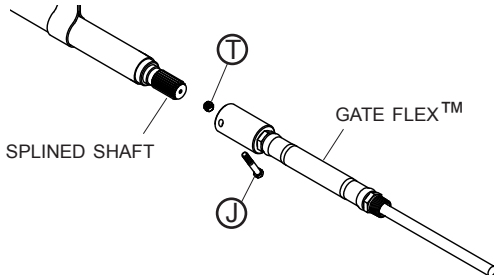
REAR OF TRAILER

STEP 1: Adjust roll tube forward or backward to align end of splined shaft with gate hinge pin.



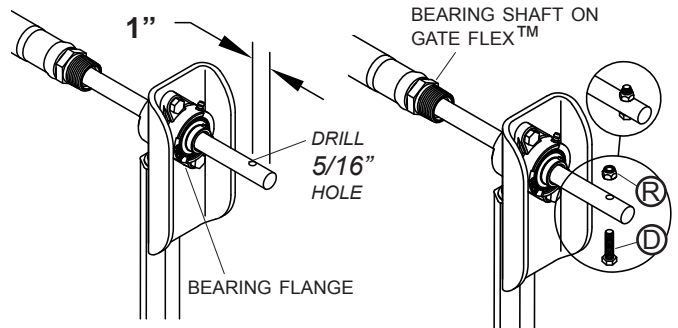
NOTE: If hinge depth is 0" to 4", set end of splined shaft 4" in from back of gate.

STEP 2: Slide Gate Flex™ completely over splined shaft on roll tube. Fasten with 3/8" x 2 1/2" cap screw and centerlock nut.



NOTE: Do not remove splined shaft. Splined shaft will be used if system is switched to manual operation.

STEP 3: Slide bearing shaft on Gate Flex™ through flange bearing on upper flex arm. Drill 5/16" hole through bearing shaft. Insert 5/16" x 1 1/2" cap screw through hole and secure with lock nut.



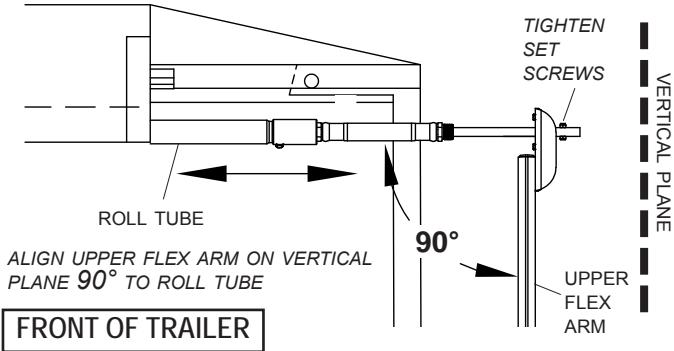
NOTE: Do not leave unattended until flex arm is securely fastened to roll tube extension as shown.



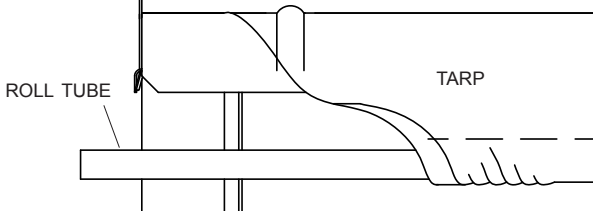
WARNING

Flex arms are under tension while torsion springs are engaged. Use caution while assembling and disassembling arms. Failure to read and follow instructions could result in serious injury or death.

STEP 4: Align upper flex arm in a vertical plane 90° to roll tube. Tighten set screws in flush mount bearing.

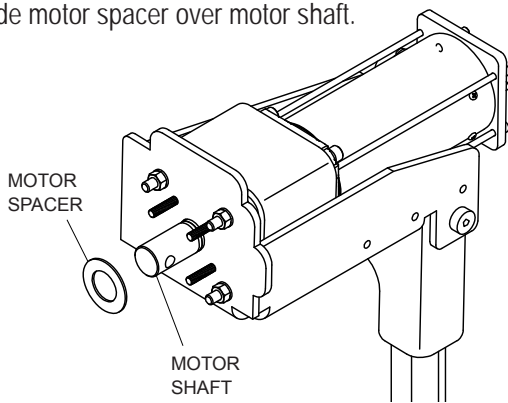


STEP 5: Slide tarp back on roll tube.

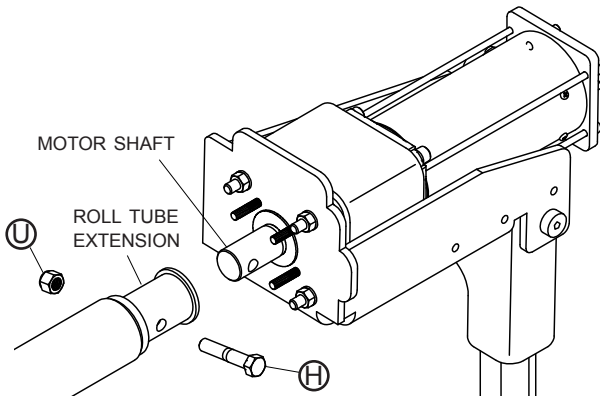


Fasten roll tube extension to motor mount bracket:

STEP 6A: Slide motor spacer over motor shaft.

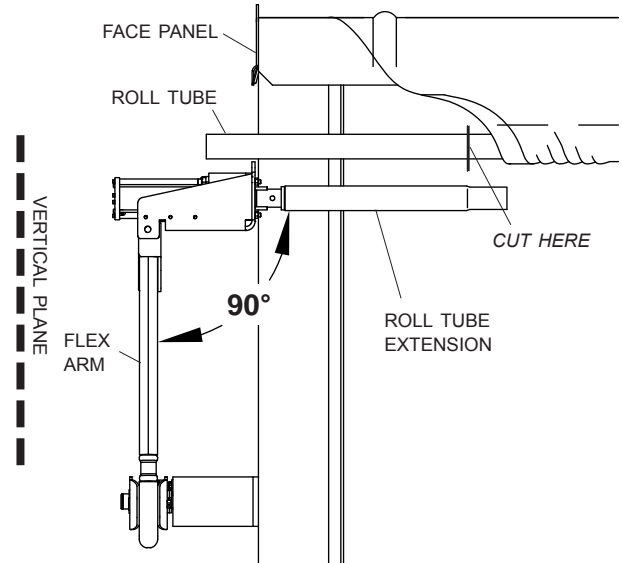


STEP 6B: Slide roll tube extension over motor shaft. Fasten with 3/8" x 2" cap screws and lock nuts. Finger tighten only.



STEP 7: Hold flex arm with motor and roll tube extension in vertical plane to trailer and 90° to roll tube. Mark and cut roll tube at location shown.

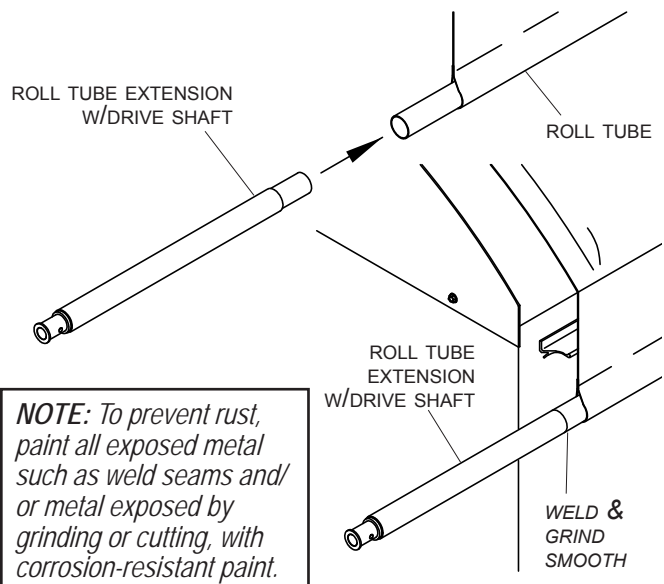
NOTE: Two people required for safe installation.



STEP 8: Unfasten and remove motor from roll tube extension. Remove roll tube extension from roll tube. Cut roll tube at marked location.

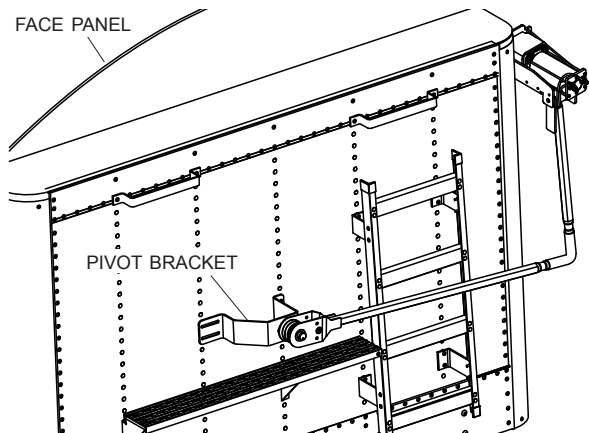
STEP 9: Insert swaged end of roll tube extension w/drive shaft into roll tube. Align extension straight with roll tube and weld all around. Grind smooth.

NOTE: Pull roll tube away from tarp and trailer before welding to protect from weld spatter. Align roll tube extension straight with roll tube before welding so tarping system will roll smoothly.



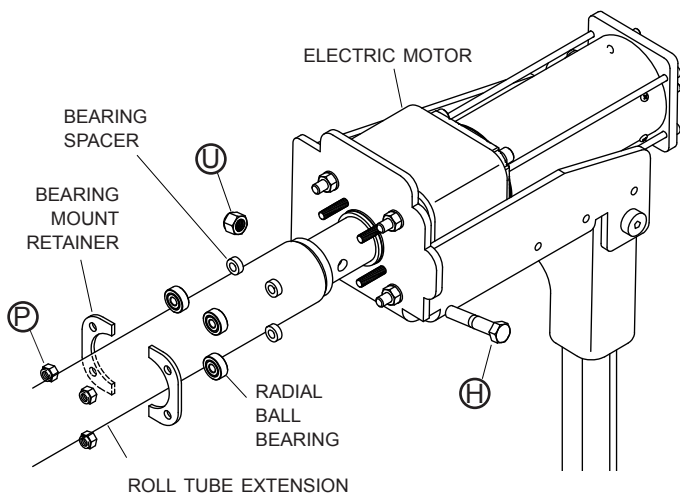
NOTE: To prevent rust, paint all exposed metal such as weld seams and/or metal exposed by grinding or cutting, with corrosion-resistant paint.

STEP 10: Slide roll tube/roll tube extension weldment back into position and align upper flex arm on front of trailer. Follow step 11 to install motor, positioning motor as shown below. Make sure torsion springs load when tarp opens.



⚠ WARNING
Flex arms are under tension while torsion springs are engaged. Use caution while assembling and disassembling arms. Failure to read and follow instructions could result in serious injury or death.

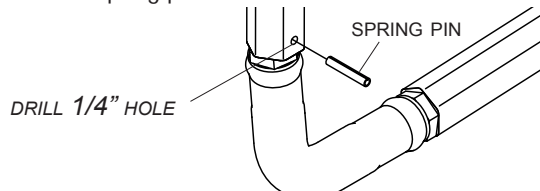
STEP 11: Refasten and secure roll tube to electric motor shaft with 3/8" x 2" cap screw and lock nut. Install bearing spacers, radial ball bearings and bearing mount retainer and secure with 1/4" lock nuts.



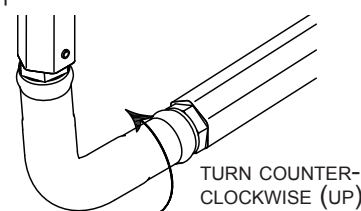
NOTE: Verify again that flex arm is on a vertical plane and is parallel to the face panel before proceeding. Make sure all fasteners holding motor to upper flex arm bracket are tightened securely.

STEP 12: Refasten tarp to roll tube with existing U-clamps and screws. Tighten all fasteners securely. Tighten front and rear flex arm connections.

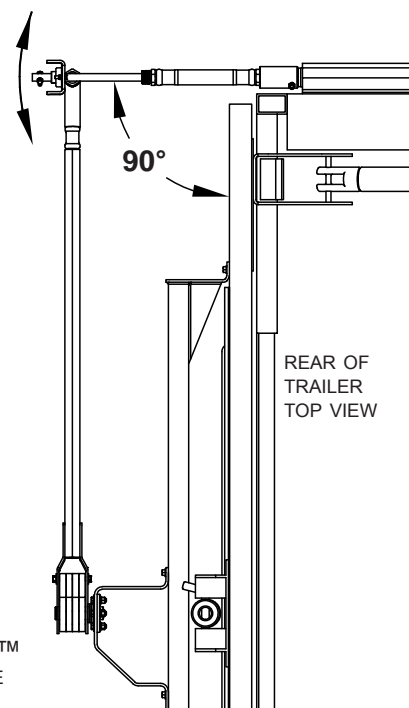
STEP 13: On rear arm only, drill 1/4" hole through flex arm joint assembly and upper flex arm. Install 1/4" x 1 1/2" spring pin into hole.



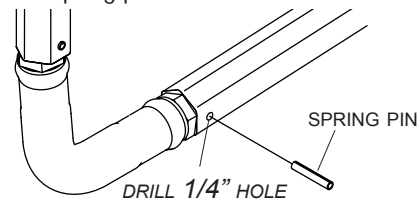
STEP 14: Place wrench on flex arm joint next to lower flex arm. Turn flex arm joint counter-clockwise (up). This will move upper flex arm and Gate Flex™ from side to side.



STEP 15: Keep turning flex arm joint until Gate Flex™ is parallel to side of trailer and 90° to rear door.

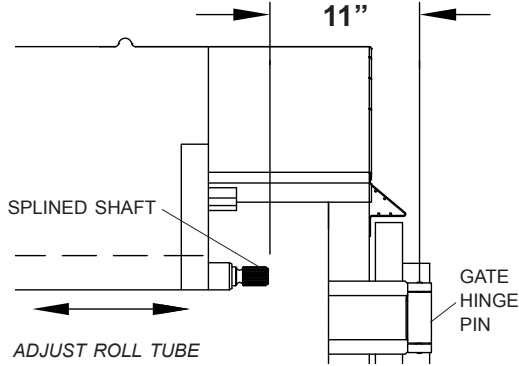


STEP 16: Drill 1/4" hole through flex arm as shown. Install 1/4" x 1 1/2" spring pin into drilled hole.

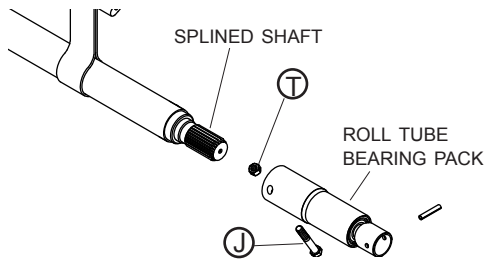


REAR OF TRAILER

STEP 1: Adjust roll tube forward or backward so end of splined shaft is 11" from center line of gate hinge pin.

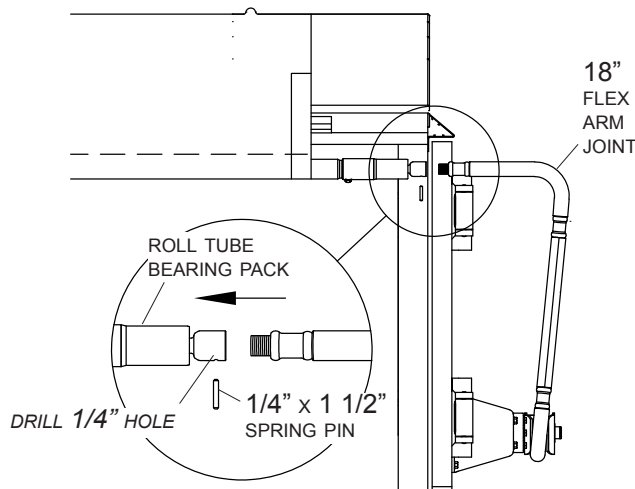


STEP 2: Slide roll tube bearing pack completely over splined shaft on roll tube. Fasten with 3/8" x 2 1/2" cap screw and centerlock nut.



NOTE: DO NOT remove splined shaft. Splined shaft will be used if system is switched to manual operation.

STEP 3: Screw 18" flex arm joint into roll tube bearing pack. Drill 1/4" hole through bearing pack and secure flex arm joint to bearing pack with 1/4" x 1 1/2" spring pin.

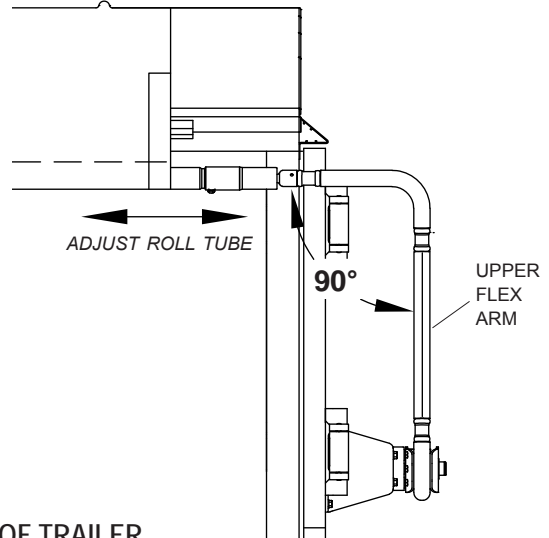


NOTE: DO NOT leave unattended until flex arm is securely fastened to roll tube extension as shown.

WARNING

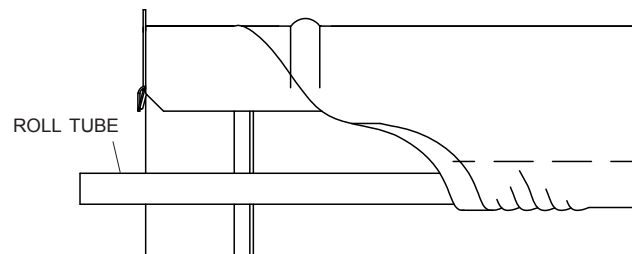
Flex arms are under tension while torsion springs are engaged. Use caution while assembling and disassembling arms. Failure to read and follow instructions could result in serious injury or death.

STEP 4: Align upper flex arm in a vertical plane 90° to roll tube.



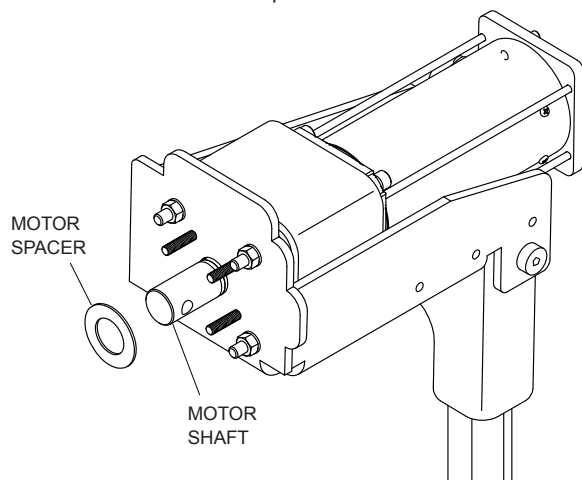
FRONT OF TRAILER

STEP 5: Slide tarp back on roll tube.

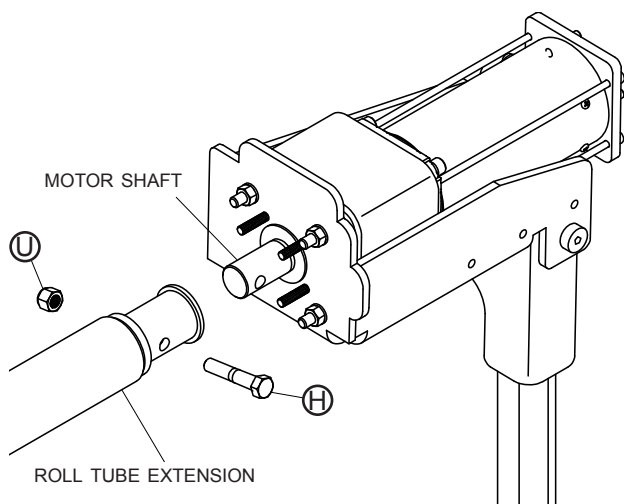


Fasten roll tube extension to motor mount bracket:

STEP 6A: Slide motor spacer over motor shaft.

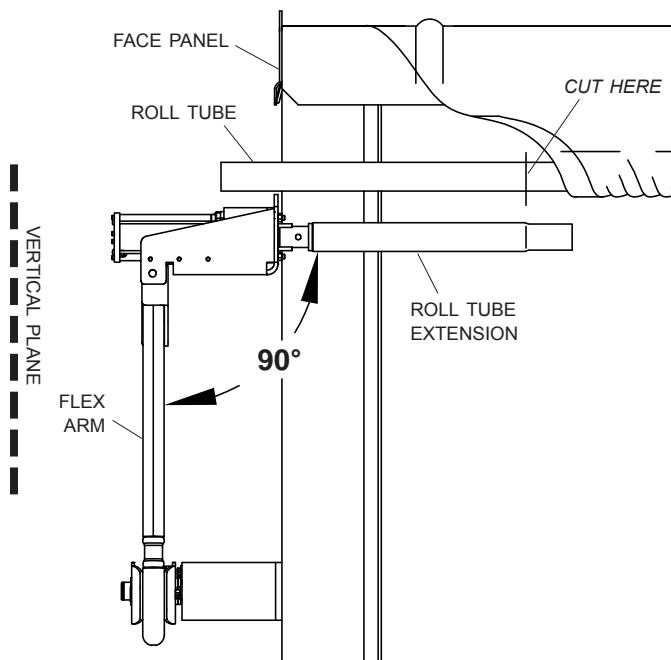


STEP 6B: Slide roll tube extension over motor shaft. Fasten with 3/8" x 2" cap screws and lock nuts. Finger tighten only.



STEP 7: Hold flex arm with motor and roll tube extension in vertical plane to trailer and 90° to roll tube. Mark and cut roll tube at location shown.

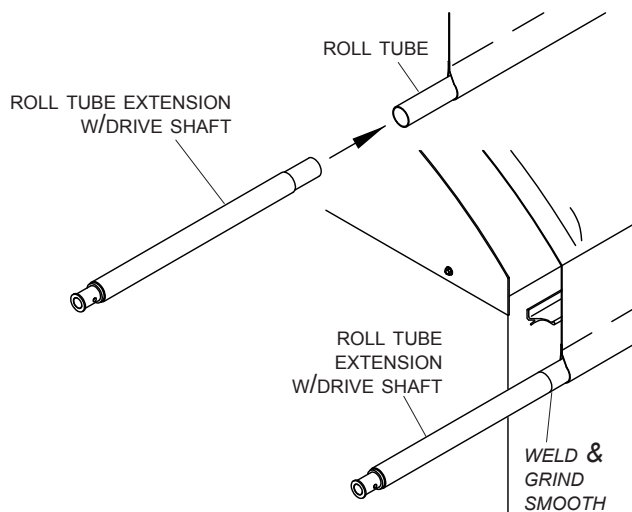
NOTE: Two people required for safe installation.



STEP 8: Unfasten and remove motor from roll tube extension. Remove roll tube extension from roll tube. Cut roll tube at marked location.

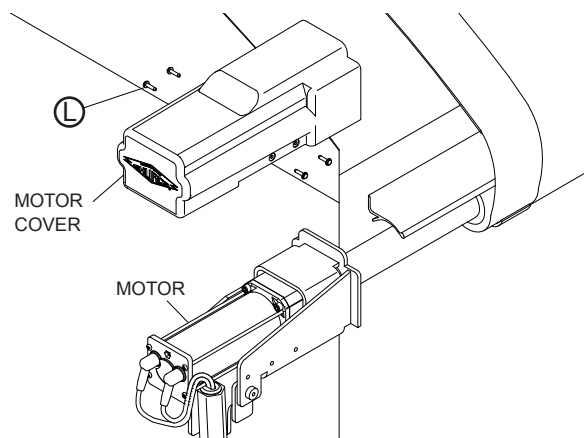
STEP 9: Insert swaged end of roll tube extension w/drive shaft into roll tube. Align extension straight with roll tube and weld all around. Grind smooth.

NOTE: Pull roll tube away from tarp and trailer before welding to protect from weld spatter. Align roll tube extension straight with roll tube before welding so tarping system will roll smoothly.

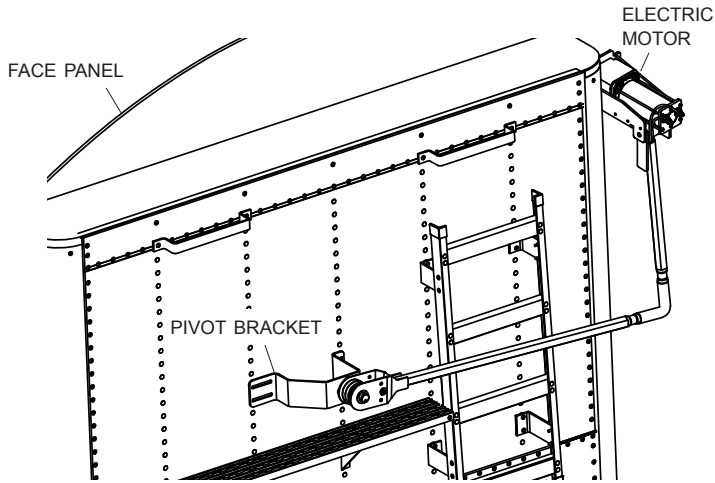


NOTE: To prevent rust, paint all exposed metal, such as weld seams and/or metal exposed by grinding or cutting, with corrosion-resistant paint.

STEP 10: Fasten motor cover onto motor with #10 x 3/4" screws.



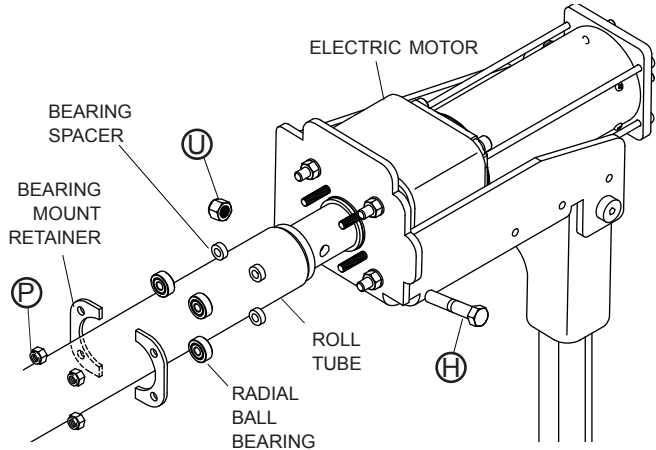
STEP 10: Slide roll tube/roll tube extension weldment back into position and align upper flex arm on front of trailer. Follow steps 6 A and B to install motor, positioning motor as shown below. Make sure torsion springs load when tarp opens.



WARNING

Flex arms are under tension while torsion springs are engaged. Use caution while assembling and disassembling arms. Failure to read and follow instructions could result in serious injury or death.

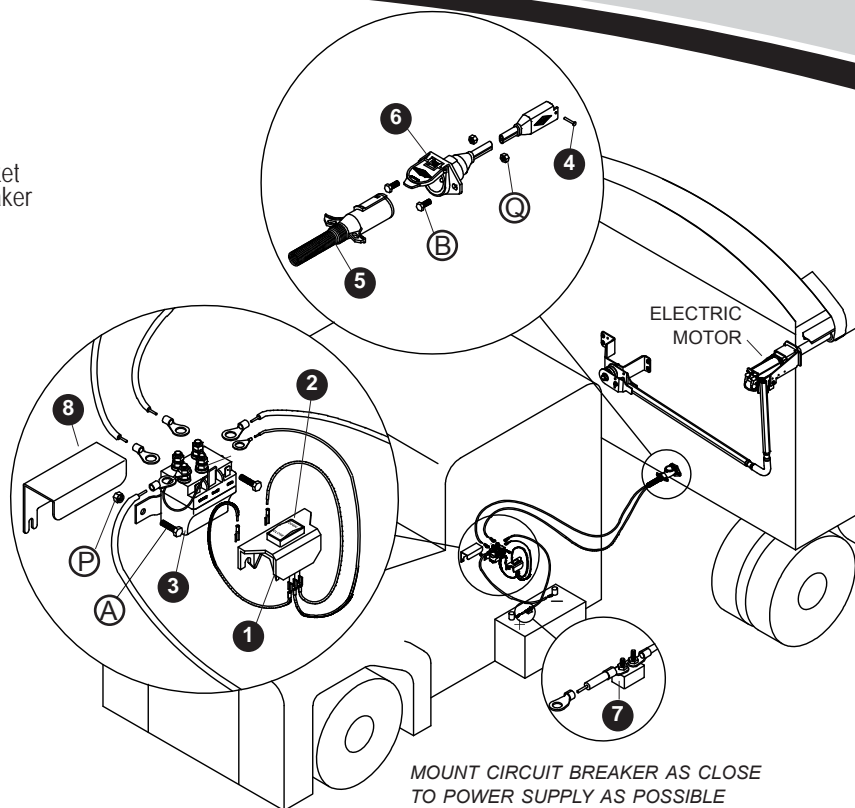
STEP 11: Refasten and secure roll tube to electric motor shaft with 3/8" x 2" cap screw and lock nut. Install bearing spacers, radial ball bearings and bearing mount retainer and secure with 1/4" lock nuts.



NOTE: Verify again that flex arm is on a vertical plane and is parallel to the face panel before proceeding. Make sure all fasteners holding motor to bearing mount plate to upper flex arm are tightened securely.

STEP 12: Refasten tarp to roll tube with existing U-clamps and screws. Tighten all fasteners securely. Tighten front and rear flex arm connections.

Item	Part #	Description
1.	1703661	Rocker Switch Mounting Bracket
2.	1116020	Rocker Switch
3.	1703845	Motor Reversing Solenoid
4.	1704751	Harness Lock Pin - 1/4" x 7/8"
5.	1115385	Heavy-Duty Dual Conductor Plug
6.	1120670	SMARTwire™ Dual Conductor Socket
7.	1704354	40-Amp Modified-Reset Circuit Breaker
8.	1703896	Solenoid Cover
A.	1700381	Cap Screw - 1/4" x 1"
B.	1701045	Cap Screw - 5/16" x 3/4"
P.	1700408	Hex Nut - 1/4"
Q.	1700411	Hex Nut - 5/16"

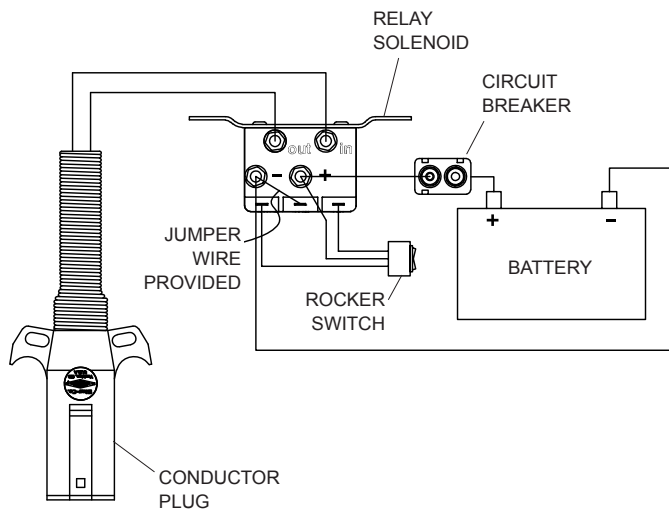


Cut wires to length and strip only enough wire insulation to install ring terminals. Insert bare wire into ring terminals and crimp securely.

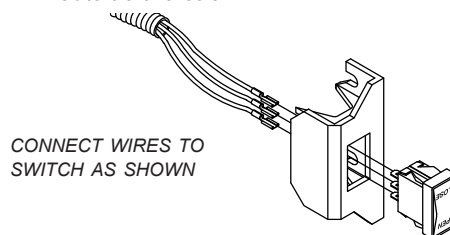
STRIP WIRE INSULATION
RING TERMINAL
CRIMP SECURELY

STEP 1: Mount circuit breaker as close as possible to battery or power supply.

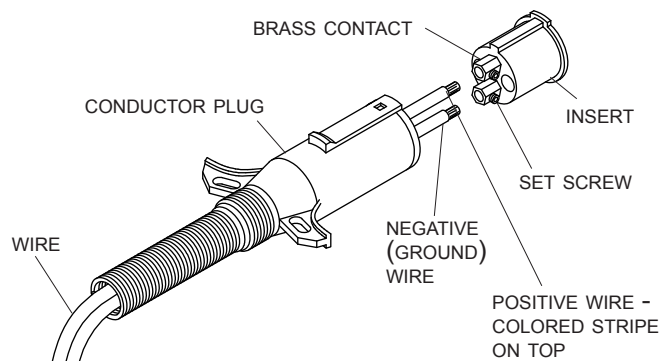
STEP 2: Mount solenoid in a suitable location - a ventilated area near the battery is ideal. Determine best route for wire. This is usually along the frame with existing wire harness. Run 6 ga. wire from conductor plug to solenoid and from power supply to solenoid as shown in diagram. Run 14 ga. wires from solenoid to switch.

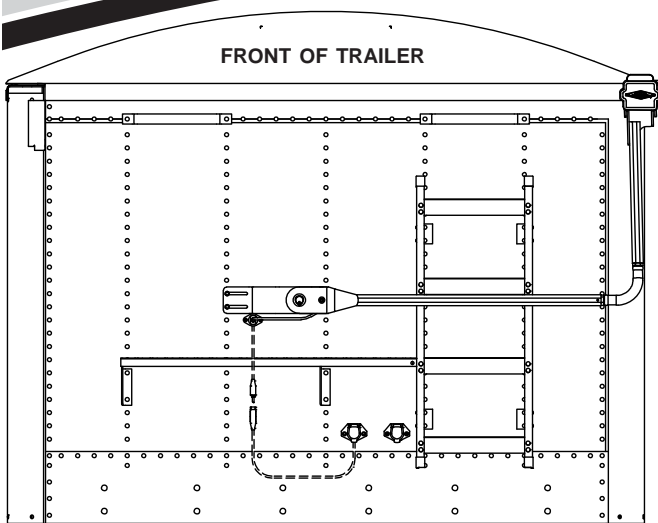


STEP 3: Locate rocker switch in a convenient operating location. Switch can be mounted in cab, on dash panel, on driver side door jamb or in a convenient location outside the cab.



STEP 4: Unfasten and remove insert from conductor plug. Feed 6 ga. wire through plug and into brass contacts on insert. Tighten set screws to secure wires. Replace insert into conductor plug and secure screw.

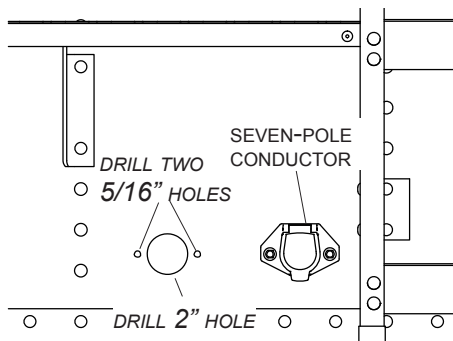




NOTE: Wire lengths are predetermined. Before installing SMARTwire™ components, review and confirm wire routing so wires will reach components with ample room for connection.

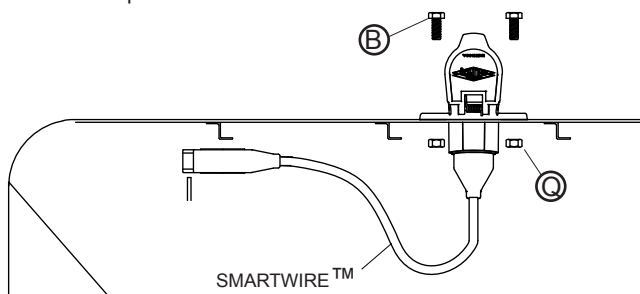
DUAL CONDUCTOR

STEP 1: Locate dual-pole conductor socket near seven-pole conductor socket as shown. Determine location and drill 2" hole through trailer skin.

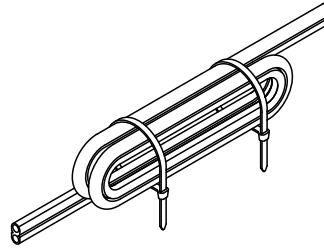


STEP 2: Align socket over 2" hole. Using holes in flanges on socket as a guide, mark and drill two 5/16" holes.

STEP 3: Fasten conductor socket to trailer with 5/16" x 3/4" cap screws and nuts.



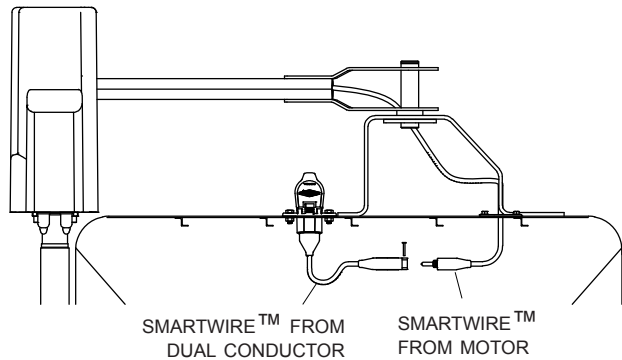
CAUTION



Do not cut SMARTwire™. Bind excess wire with cable ties.

WIRING SCHEMATIC

STEP 1: Connect SMARTwire™ from electric motor to SMARTwire™ from dual conductor and secure connection with lock pin. Secure all wires to trailer with cable clips and screws. If needed, use cable ties.



NOTE: Coat each connection with dielectric grease (P/N 1704378) to prevent corrosion.

CAUTION

Check all hardware for complete assembly before operating. Inspect system at this time and adjust as required.

OPERATION:

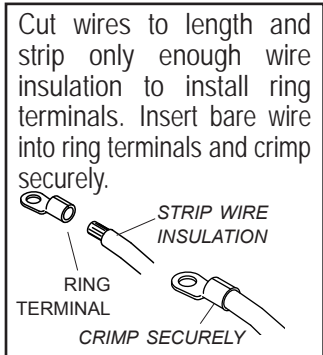
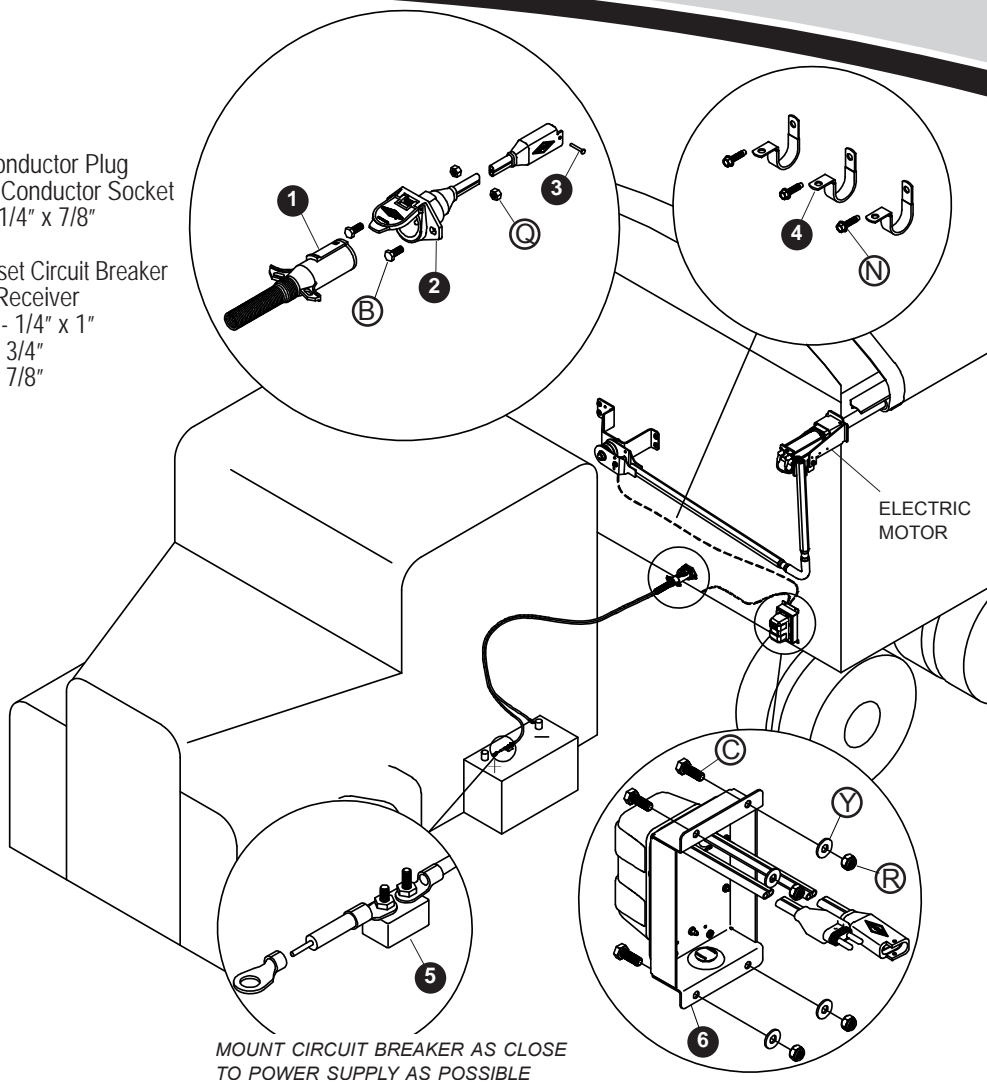
A) Check motor direction by activating switch to "OPEN". If switch is running system backwards, change wire leads on dual conductor plug to opposite connections.

B) Close tarp: Push switch to "CLOSE" and hold. Observe tarp and release switch when tarp is fully closed.

C) Open tarp: Push switch to "OPEN" and hold. Observe tarp and release switch when tarp is fully opened.

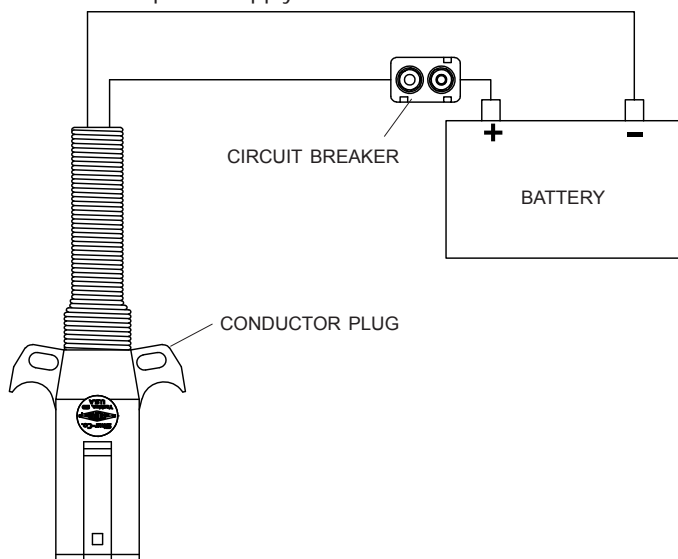
NOTE: Release switch at end of cycle or modified-reset circuit breaker will trip. After breaker resets, switch will activate motor again. To reduce unnecessary strain on tarp components, release switch at end of each cycle.

Item	Part #	Description
1.	1115385	Heavy-Duty Dual Conductor Plug
2.	1120670	SMARTwire™ Dual Conductor Socket
3.	1109015	Harness Lock Pin - 1/4" x 7/8"
4.	1702108	Wire Clip - 3/4"
5.	1704354	40-Amp Modified-Reset Circuit Breaker
6.		Shur-Co® Wireless Receiver
N.	1704338	Self-Tapping Screw - 1/4" x 1"
B.	1701045	Cap Screw - 5/16" x 3/4"
C.	1702926	Cap Screw - 5/16" x 7/8"
Q.	1700411	Hex Nut - 5/16"
R.	1700419	Lock Nut - 5/16"
Y.	1201237	Flat Washer - 5/16"

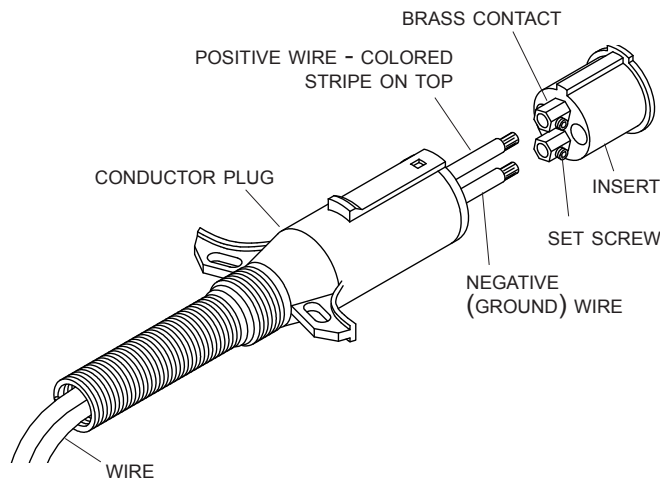


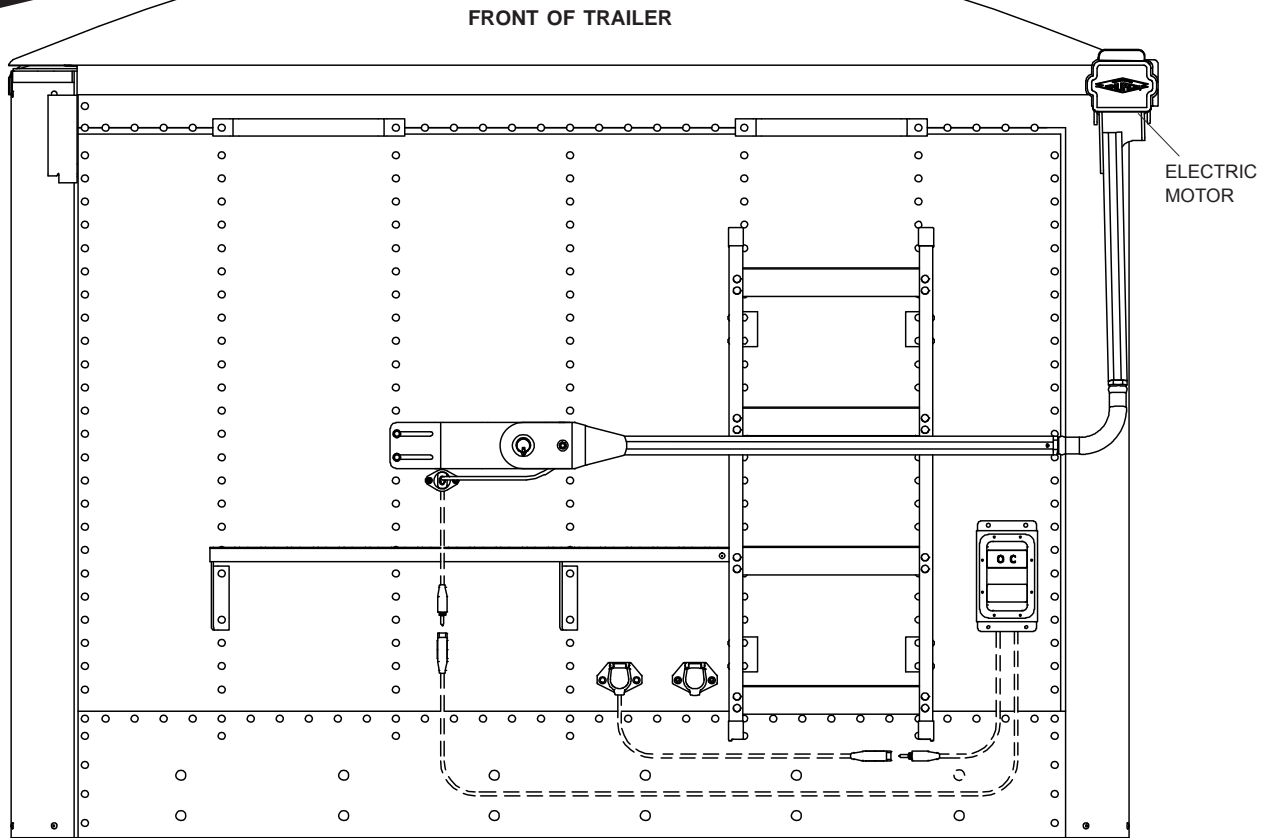
MOUNT CIRCUIT BREAKER AS CLOSE TO POWER SUPPLY AS POSSIBLE

STEP 1: Mount circuit breaker as close as possible to battery or power supply.



STEP 2: Unfasten and remove insert from conductor plug. Feed 6 ga. wire through plug and into brass contacts on insert. Tighten set screws to secure wires. Replace insert into conductor plug and secure screw.

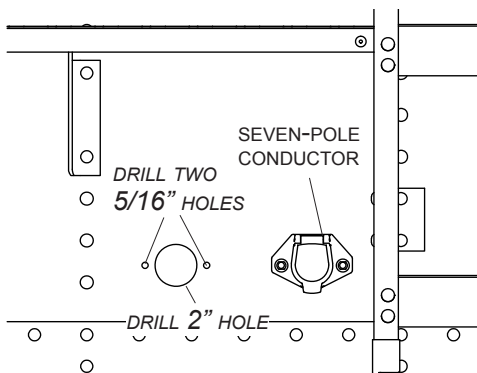




NOTE: Wire lengths are predetermined. Before installing SMARTwire™ components, review and confirm wire routing so that wires will reach components with ample room for connection.

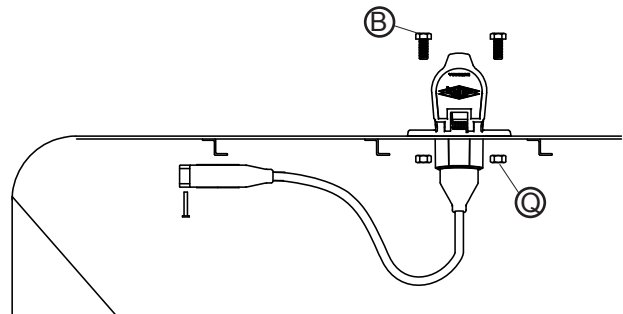
DUAL CONDUCTOR SOCKET

STEP 1: Locate dual-pole conductor socket near seven-pole conductor socket as shown. Determine location and drill 2" hole through trailer skin.



STEP 2: Align socket over 2" hole. Using holes in flanges on socket as a guide, mark and drill two 5/16" holes.

STEP 3: Fasten conductor socket to trailer with 5/16" x 3/4" cap screws and nuts.

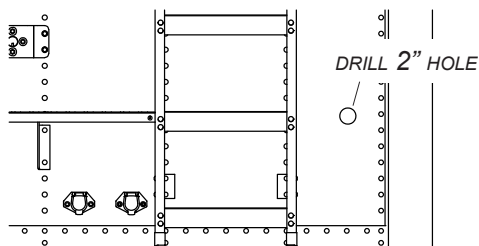


CAUTION

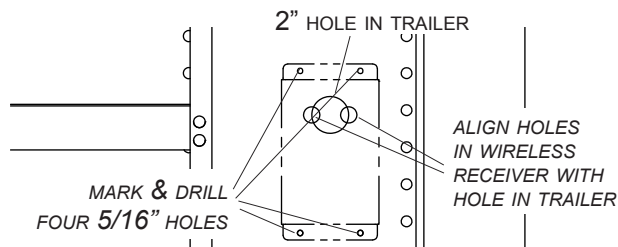
Do not fasten SMARTwire™ components to trailer through hopper walls.

SHUR-CO® WIRELESS RECEIVER

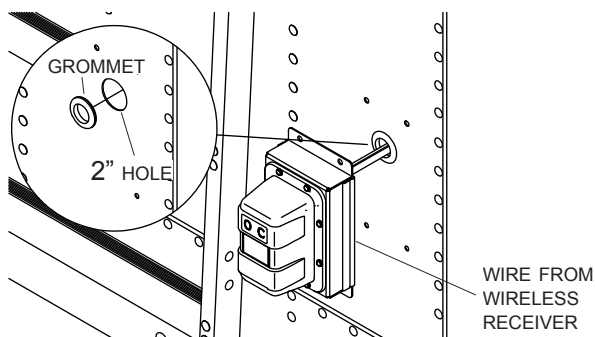
STEP 1: Locate Shur-Co® wireless receiver as shown on front view. Determine location and drill 2" hole through trailer skin.



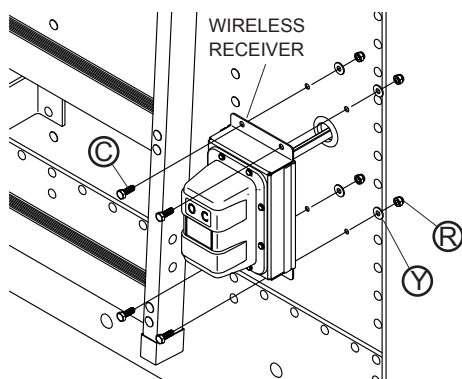
STEP 2: Align holes in wireless receiver over 2" hole in trailer as shown below. Using holes on flanges on receiver as a guide, mark and drill four 5/16" holes as shown.



STEP 3: Install grommet into 2" hole. Insert wire from wireless receiver through grommet.

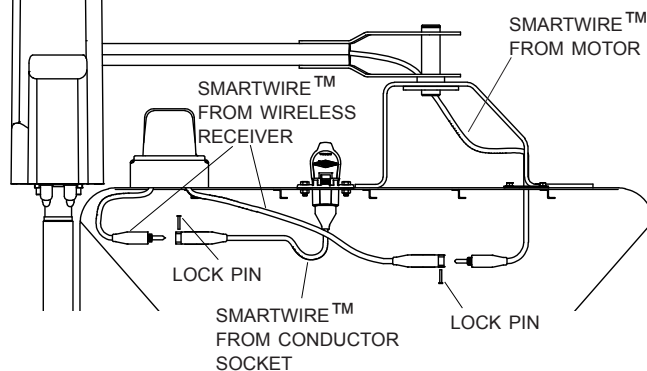


STEP 4: Align holes on wireless receiver with holes on trailer. Fasten receiver to trailer with 5/16" x 7/8" cap screws, lock washers and nuts.



WIRING SCHEMATIC

STEP 1: Connect SMARTwire™ from wireless receiver to SMARTwire™ from electric motor. Connect SMARTwire™ from wireless receiver to SMARTwire™ from conductor socket. Secure connections with lock pins. Secure wires to trailer with cable clips and screws. If needed, use cable ties.



NOTE: Coat each connection with dielectric grease (P/N 1704378) to prevent corrosion.

CAUTION

Check all hardware for complete assembly before operating. Inspect system at this time and adjust as required.

OPERATION:

A) Check motor direction by activating switch to "OPEN." If switch is running system backwards, change wire leads on dual conductor plug to opposite connections.

B) Close tarp: Push switch to "CLOSE" and hold. Observe tarp and release switch when tarp is fully closed.

C) Open tarp: Push switch to "OPEN" and hold. Observe tarp and release switch when tarp is fully opened.

NOTE: Release switch at end of cycle or modified-reset circuit breaker will trip. After breaker resets, switch will activate motor again. To reduce unnecessary strain on tarp components, release switch at end of each cycle.

NOTE: The receiver may be pressure washed, but keep nozzle at least 3' from system while spraying.

Power-up/down:

The transmitter will power up when the lid is opened. The transmitter will power down when the lid is closed or when the lid is left open, three minutes after the last button is pushed.

Standard operation:

After power-up, the first channel will be immediately active and the LED indicator for this channel will be flashing. The *Open/On* and *Close/Off* buttons are operational for the indicated active channel. While pressed, the LED indicator will flash faster, indicating channel operation.

The *Select* button will cycle between enabled channels. If only one channel is enabled, there will be no apparent change when the *Select* button is pressed.

Channel Programming Mode:

The Shur-Co® SMARTransmitter® has five channels. Pressing the *Select* button toggles through these channels. Unused channels can be disabled if desired, using the following process, but your transmitter is fully operational as shipped. This process may be skipped. Unused transmitter channels will not perform any functions.

Hold the *Select* button down for 10 seconds and the transmitter will enter *Channel Programming Mode*. Each time *Channel Programming Mode* is entered, the status of all five channels must be reset.

While In *Channel Programming Mode*, the programmable channel will be indicated by a solid lit LED.

NOTE: The transmitter will NOT activate any motor or lighting system while the transmitter is in *Channel Programming Mode*.

Press the *Open/On* button to enable the current channel (designated by the indicator light). Press the *Close/Off* button to disable the current channel. The indicator light will automatically jump to the next channel.

After programming all five channels, the transmitter will display the programmed channel status for all channels for three seconds. All enabled-channel LEDs will be lit solid and all disabled-channel LEDs will not be lit. Buttons will not function during this three-second period.

The transmitter will automatically exit *Channel Programming Mode* after three seconds and return to *Operational Mode*.

NOTE: If there is not at least one enabled channel after programming, the transmitter will not save the changes and will revert back to the previously saved channel settings.

TIP: To cancel your changes and exit *Channel Programming Mode*, close the transmitter cover.

Channel programming example:

The transmitter in this example is labeled with the following five channels:

- Tarp System
- Front Hopper
- Back Hopper
- Lights
- Auxiliary

These channel labels are for a standard agricultural transmitter. Your transmitter label may differ.

The task is to enable the *Tarp System*, *Front Hopper* and *Back Hopper* channels.

1. Hold down the *Select* button for 10 seconds. The transmitter will enter *Learn Mode*. The *Tarp System* channel LED will be lit. All other channel LEDs are off.
2. Press the *Open/On* button to enable the *Tarp System* channel. The *Front Hopper* LED will be lit.
3. Press the *Open/On* button to enable the *Front Hopper*. The *Back Hopper* LED will be lit.
4. Press the *Open/On* button to enable the *Back Hopper*. The *Lights* channel LED will be lit.
5. Press the *Close/Off* button to disable the lights. The *Auxiliary* LED will be lit.
6. Press the *Close/Off* button to disable the *Auxiliary* channel LED.
7. The transmitter will display all activated channels for three seconds. The transmitter will automatically exit *Channel Programming* and revert to *Operational Mode*. The *Tarp System* LED will be flashing, indicating that the channel is active and ready for operation.

SMARTransmitter® to receiver programming:

Shur-Co® SMARTrailer® wireless systems are typically pre-programmed at the factory or by the dealer and should be ready to use as shipped. Re-programming is necessary after replacement transmitters or receivers are installed.

Use the following method to program the RF receiver to accept and respond to signals from up to five transmitters. The receiver will not accept or respond to signals from transmitters that have not been programmed using this method.

1. Remove the receiver cover, pulling gently on the cover to prevent damage to wires that are connected to the rocker switch.
2. Check to be sure the 4500 Series is connected to the power supply. The receiver must be connected to power to be programmed. If a battery disconnect switch is installed, make sure it is turned on.
3. The receiver can learn to recognize and respond to up to five transmitters. Gather all of the transmitters to be introduced to the receiver. Open the transmitter lid(s) in order to turn them on.
4. Set the transmitter(s) to the appropriate channel (*Tarp System*, etc.). See *Transmitter Operation & Programming Instructions*.

NOTE: Read the following steps in their entirety before proceeding. steps 6 to 8 must be completed within 10 seconds.

5. Press and hold the programming button on the bottom of the RF solenoid for five seconds. The solenoid will beep to indicate that it is in programming mode. Release the programming button.
6. Press the *Open/On* button on the first transmitter being introduced. The receiver will beep after receiving the transmitter signal.
7. Repeat step 6 for any remaining transmitters.
8. The receiver will expect five signals, so if you are programming less than five transmitters, press the *Open/On* button additional times on the last transmitter you are programming. Push the *Open/On* button a total of five times (see programming example).
9. After pushing the *Open/On* button five times, the receiver will beep twice to indicate that it has been programmed successfully.

NOTE: The receiver will exit program mode after 10 seconds, whether or not it has five *Open/On* button signals.

10. Verify that each transmitter is operating correctly. If none of the transmitters are operating correctly, verify that there are 12 to 14 volts from the receiver positive to negative, then repeat steps 3 to 9.

11. Refasten receiver cover.

Receiver programming example:

In this example, the receiver controls the 4500 Series motor. The task is to program the receiver to recognize three transmitters.

1. Remove the receiver cover and turn on the three transmitters.
2. Set all three transmitters to the tarp system channel.
3. Press and hold the programming button on the RF solenoid for five seconds. The solenoid will beep to indicate it has entered *Channel Programming Mode*. Release the programming button.
4. Press the *Open/On* button on the first transmitter. The receiver will beep to indicate that it has received a signal and memory slot #1 has been filled.
5. Press the *Open/On* button on the second transmitter. The receiver will beep to indicate that it has received a signal and memory slot #2 has been filled.
6. Press the *Open/On* button on the third transmitter. The receiver will beep to indicate that it has received a signal and memory slot #3 has been filled.
7. Press the *Open/On* button on the third transmitter again. The receiver will beep to indicate that it has received a signal and memory slot #4 has been filled.
8. Press the *Open/On* button on the third transmitter again. The receiver will beep twice to indicate that it has received a signal and memory slot #5 has been filled. The double beep also indicates that the receiver has exited programming mode.
9. Verify that the tarp system *Open* and *Close* operations are functioning correctly on all three transmitters.
10. Refasten the receiver cover to motor assembly.



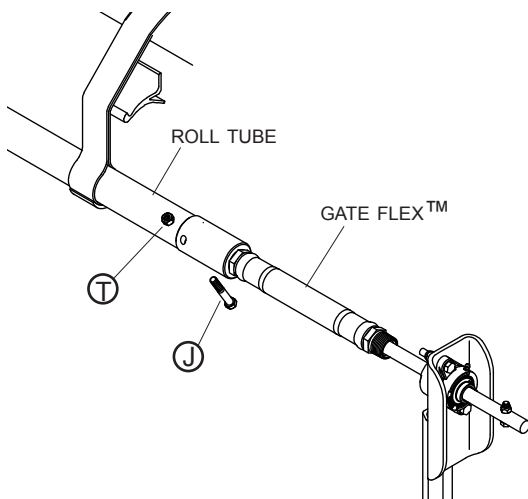
WARNING

Flex arms are under tension while torsion springs are engaged. Use caution while assembling and disassembling arms. Failure to read and follow instructions could result in serious injury or death.

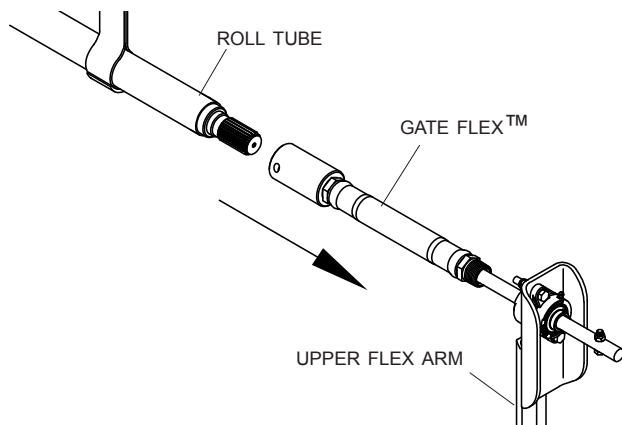
NOTE: Store manual crank arm either in truck or mounted to trailer. (Example: above kingpin in apex.)

Perform the following steps to convert your 4500 Series Electric Top Hinge system to a manual crank operation. The same steps apply to convert the Side Hinge system.

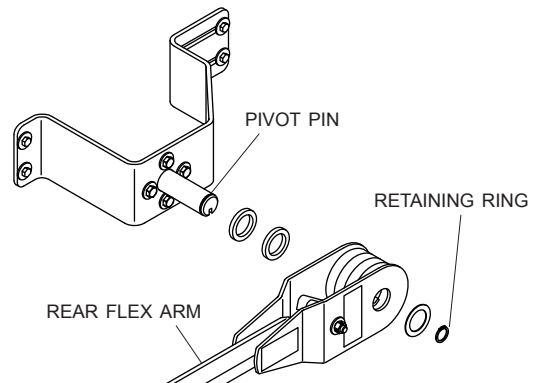
STEP 1: Close tarp but let roll tube hang loose under latchplate. Remove 3/8" x 2 1/2" cap screw and lock nut from Gate Flex™.



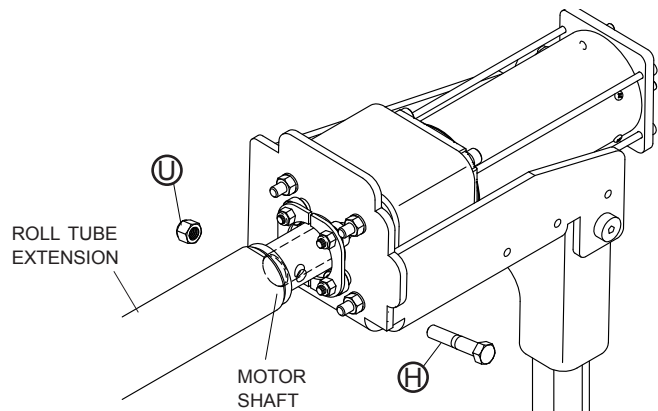
STEP 2: Carefully slide Gate Flex™ off roll tube. Flex arm will be under tension and have some downward force.



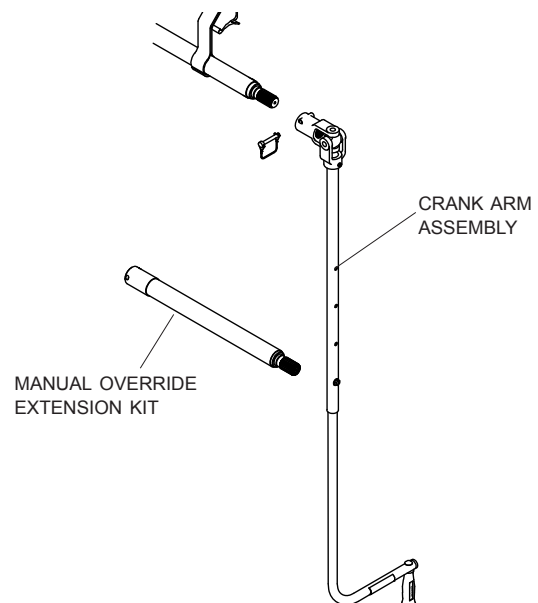
STEP 3: Remove retaining ring on rear flex arm. Carefully slide arm off from pivot pin.



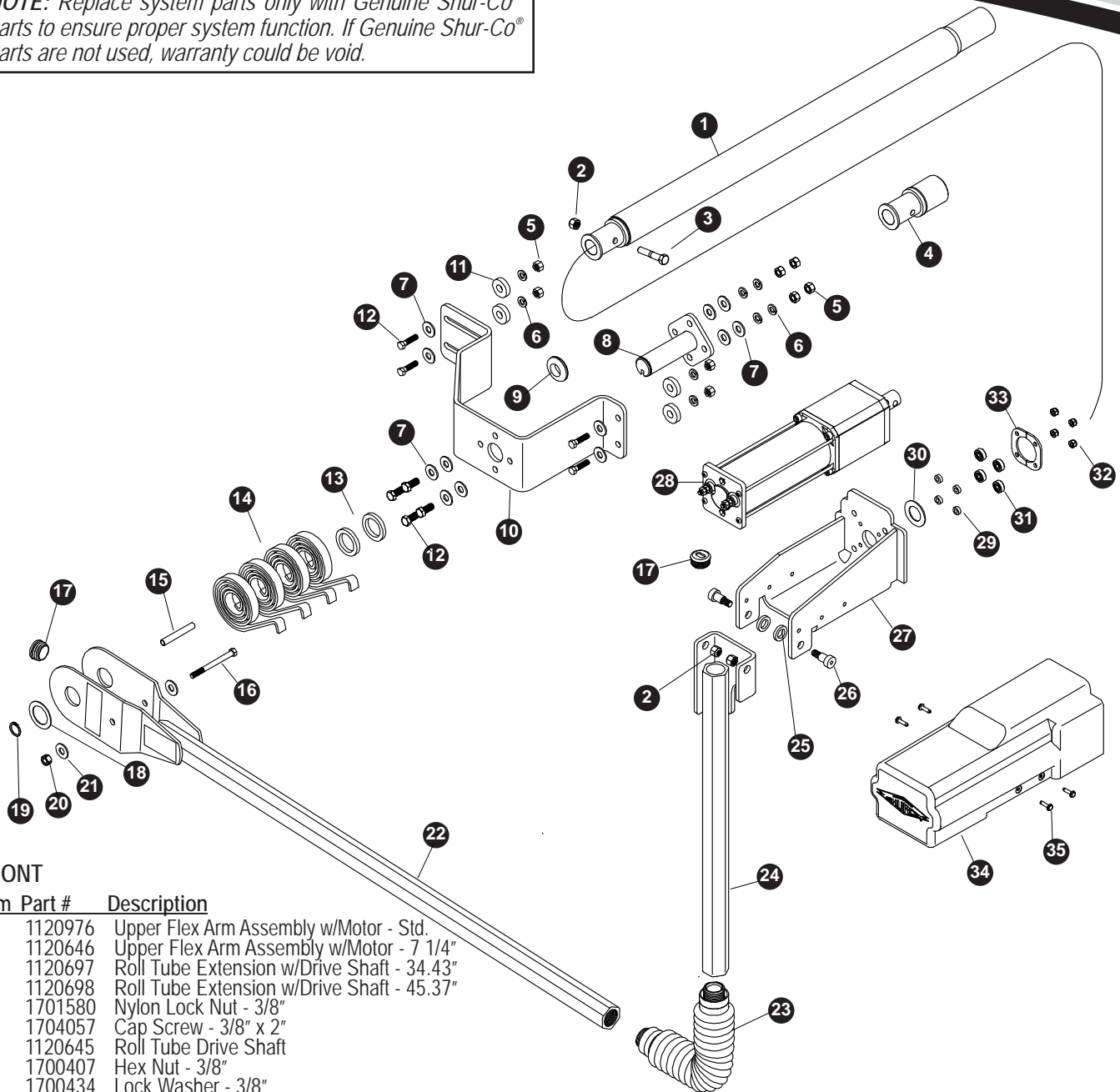
STEP 4: At front of trailer, remove 3/8" x 2" cap screw and lock nut from motor shaft and roll tube extension connection.



STEP 5: Install crank arm assembly as shown in the Shur-Lok® owner's manual. Owner's manual may be viewed at <http://www.shurco.com>. You may need optional manual override extension kit - P/N 1117022.



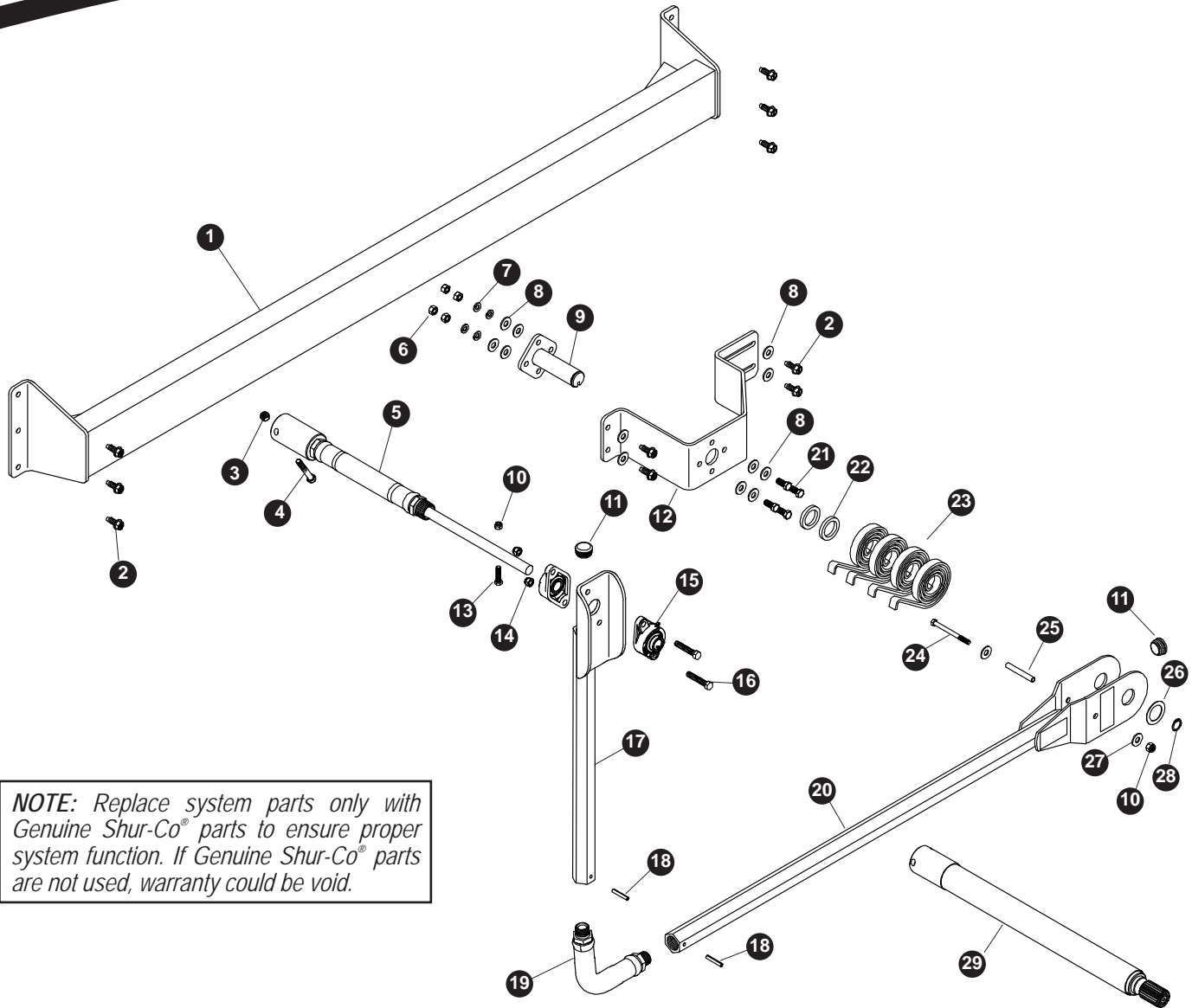
NOTE: Replace system parts only with Genuine Shur-Co® parts to ensure proper system function. If Genuine Shur-Co® parts are not used, warranty could be void.



FRONT

Item	Part #	Description
	1120976	Upper Flex Arm Assembly w/Motor - Std.
	1120646	Upper Flex Arm Assembly w/Motor - 7 1/4"
1.	1120697	Roll Tube Extension w/Drive Shaft - 34.43"
	1120698	Roll Tube Extension w/Drive Shaft - 45.37"
2.	1701580	Nylon Lock Nut - 3/8"
3.	1704057	Cap Screw - 3/8" x 2"
4.	1120645	Roll Tube Drive Shaft
5.	1700407	Hex Nut - 3/8"
6.	1700434	Lock Washer - 3/8"
7.	1700429	Flat Washer - 3/8"
8.	1116920	Pivot Pin - 4 Spring
9.	1703282	Rubber Grommet - 1 1/4" Insert
10.	1117927	Vertical Pivot Mt. Bracket - 12 1/4" Standoff
11.	1120291	Pivot Bracket Washer
12.	1702891	Cap Screw - 3/8" x 1 1/4"
13.	1118318	Spacer Washer - 1/4" x 1.28"
14.	1111027	Spiral Torsion Spring
15.	1117033	Spacer Tube - .35" x 2 5/8"
16.	1201022	Cap Screw - 5/16" x 3 1/2"
17.	1703882	Cap Plug w/Hole - 1 1/4"
18.	1702890	Flat Washer - 1 1/4"
19.	1702888	External Retaining Ring - 1 1/4"
20.	1700419	Nylon Lock Nut - 5/16"
21.	1700428	Flat Washer - 5/16"
22.	1116905	Lower Flex Arm

Item	Part #	Description
23.	1120703	Flex Arm Joint Assembly
24.	1120676	Upper Flex Arm - Front
25.	1120677	Upper Arm Spacer
26.	1704778	Shoulder Bolt - 1/2" x 5/8" - 3/8" x 1/2" Thd.
27.	1120776	4500 Motor Mount - 7 1/4"
	1120662	4500 Motor Mount
28.	1704750	4500 Electric Motor
29.	1120680	Motor Mt. Bearing Spacer
30.	1120679	Motor Spacer
31.	1704736	Radial Ball Bearing - 1/4" x 3/4"
32.	1701543	Nylon Lock Nut - 1/4"
33.	1120681	Motor Mt. Bearing Retainer
34.	1704769	4500 Series Motor Cover
35.	1704367	Hex Flange Cap Screw - #10 x 3/4"

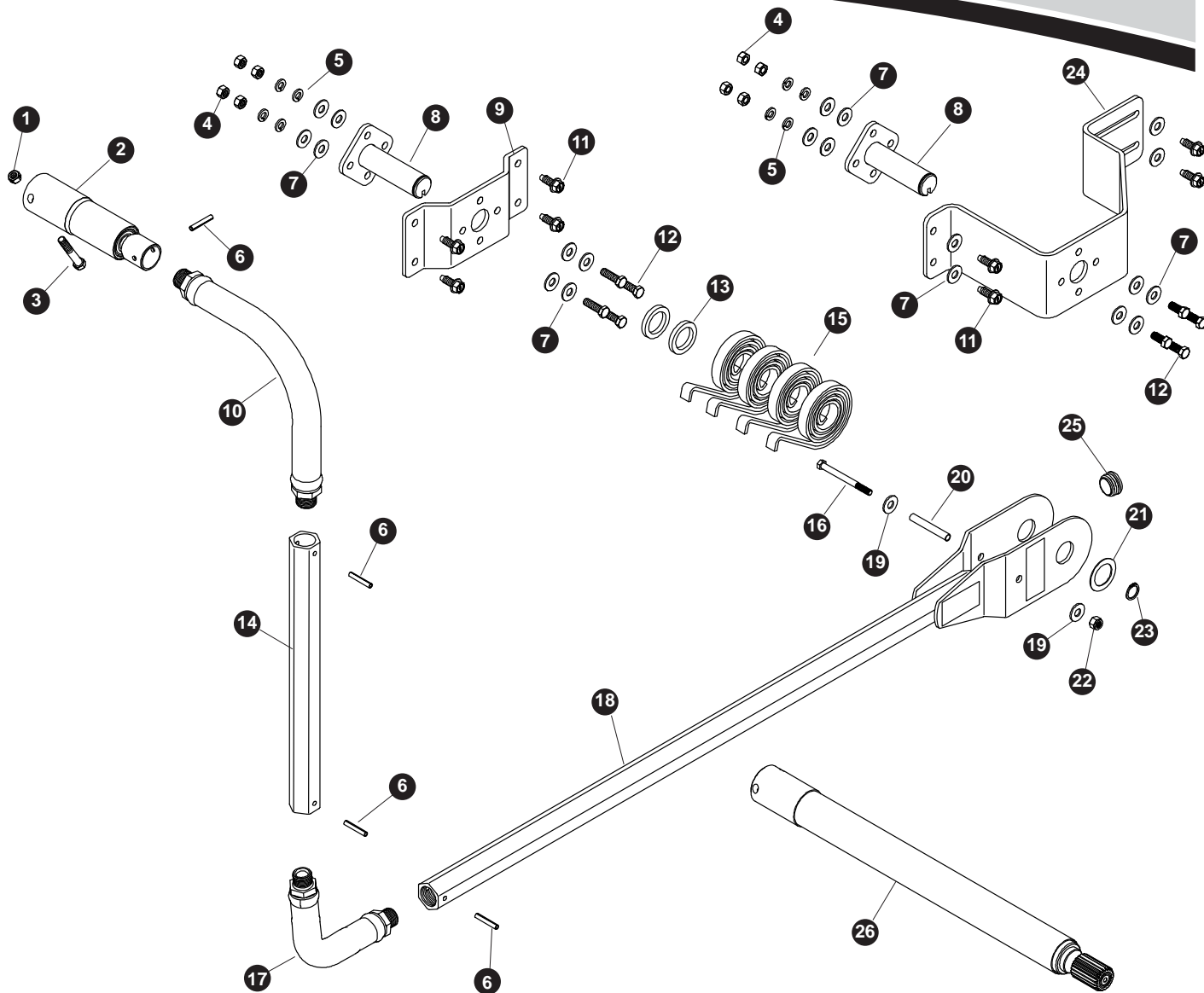


NOTE: Replace system parts only with Genuine Shur-Co® parts to ensure proper system function. If Genuine Shur-Co® parts are not used, warranty could be void.

REAR - TOP HINGE

Item	Part #	Description
1.	*	Beam Bracket
2.	1700400	Self-Tapping Screw - 3/8" x 1"
3.	1700418	Centerlock Nut - 3/8"
4.	1702573	Cap Screw - 3/8" x 2 1/2"
5.	1116990	Gate Flex™
6.	1700407	Hex Nut - 3/8"
7.	1700434	Lock Washer - 3/8"
8.	1700429	Flat Washer - 3/8"
9.	1116920	Pivot Pin - 4 Spring
10.	1700419	Nylon Lock Nut - 5/16"
11.	1703881	Cap Plug - 1 1/4" x 14-16 Ga.
12.	1116919	Pivot Mt. Bracket - Vertical - 7 1/4" Standoff
13.	1703487	Cap Screw - 5/16" x 1 1/2"
14.	1701580	Nylon Lock Nut - 3/8"
* Specify size		

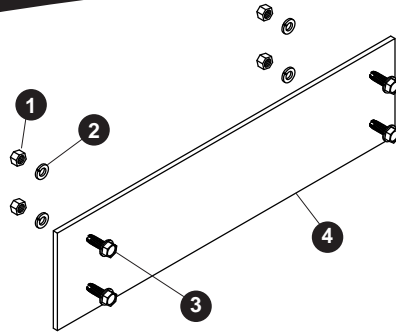
Item	Part #	Description
15.	1704703	Flange Bearing - 20mm - 2 Bolt
16.	1704264	Cap screw - 3/8" x 2"
17.	1116992	Upper Flex Arm, Gate Flex™
18.	1700445	Spring Pin - 1/4" x 1 1/2"
19.	1703873	Flex Arm Joint
20.	1116905	Lower Flex Arm
21.	1702891	Cap Screw - 3/8" x 1 1/4"
22.	1118318	Spacer Washer - 1/4" x 1.81"
23.	1111027	Spiral Torsion Spring
24.	1201022	Cap Screw - 5/16" x 3 1/2"
25.	1117033	Spacer Tube - .35" x 2 5/8"
26.	1702890	Flat Washer - 1 1/4"
27.	1700428	Flat Washer - 5/16"
28.	1702888	Retaining Ring - 1 1/4"
29.	1117022	Manual Override Extension Kit (optional)



NOTE: Replace system parts only with Genuine Shur-Co® parts to ensure proper system function. If Genuine Shur-Co® parts are not used, warranty could be void.

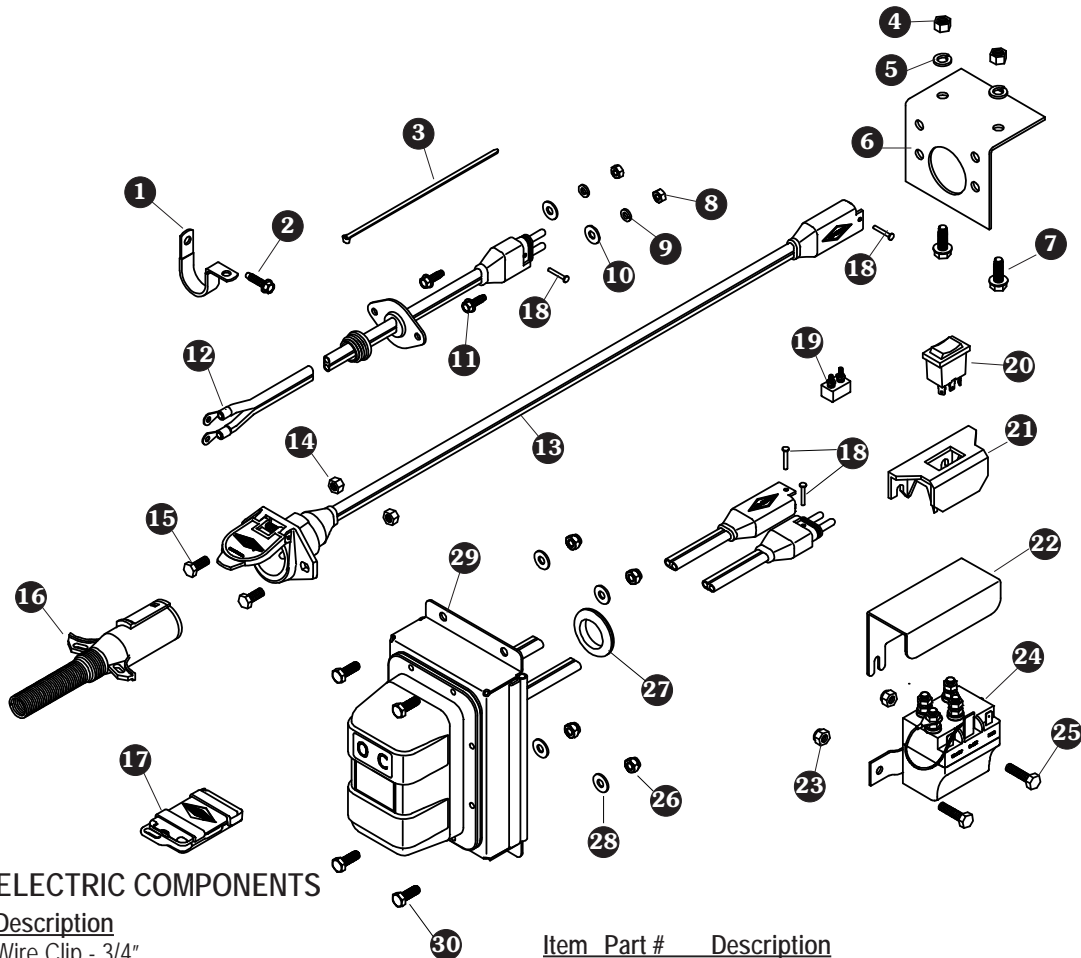
REAR - SIDE HINGE

Item	Part #	Description	Item	Part #	Description
1.	1700418	Centerlock Nut - 3/8"	14.	1117768	Upper Flex Arm - Side Hinge
2.	1117777	Roll Tube Bearing Pack	15.	1111027	Spiral Torsion Spring
3.	1702573	Cap Screw - 3/8" x 2 1/2"	16.	1201022	Cap Screw - 5/16" x 3 1/2"
4.	1700407	Hex Nut - 3/8"	17.	1703873	Flex Arm Joint - 12"
5.	1700434	Lock Washer - 3/8"	18.	1116905	Lower Flex Arm
6.	1700445	Spring Pin - 1/4" x 1 1/2"	19.	1700428	Flat Washer - 5/16"
7.	1700429	Flat Washer - 3/8"	20.	1117033	Spacer Tube - .35" x 2 5/8"
8.	1116920	Pivot Pin - 4 Spring	21.	1702890	Flat Washer - 1 1/4"
9.	1117767	Pivot Bracket	22.	1700419	Nylon Lock Nut - 5/16"
10.	1704048	Flex Arm Joint - 18"	23.	1702888	Retaining Ring - 1 1/4"
11.	1700400	Self-Tapping Screw - 3/8" x 1"	24.	1116919	Pivot Bracket - Vertical
12.	1702891	Cap Screw - 3/8" x 1 1/4"	25.	1703884	Cap Plug - 1 1/4" x 10-16 Ga.
13.	1118318	Spacer Washer - 1/4" x 1.8" x 1.28"	26.	1117022	Manual Override Extension Kit (optional)



PIVOT BACKER PLATE

Item	Part #	Description
1.	1700407	Hex Nut - 3/8"
2.	1700434	Lock Washer - 3/8"
3.	1702891	Cap Screw - 3/8" x 1 1/4"
4.	1120361	Pivot Backer Plate - 5" x 16"
	1120418	Pivot Backer Plate - 5" x 20"



4500 SERIES ELECTRIC COMPONENTS

Item	Part #	Description
1.	1702108	Wire Clip - 3/4"
2.	1704338	Self-Tapping Screw - 1/4" x 1"
3.	1703231	Cable Tie - 8"
4.	1700407	Hex Nut - 3/8"
5.	1700434	Lock Washer - 3/8"
6.	1109015	Mounting Bracket
7.	1700400	Self-Tapping Screw - 3/8" x 1"
8.	1700408	Hex Nut - 1/4"
9.	1700436	Lock Washer - 1/4"
10.	1700427	Flat Washer - 1/4"
11.	1700403	Self-Tapping Screw - 1/4" x 3/4"
12.	1120816	SMARTwire™ - 6 Ga. - Plug - 9' 9"
13.	1120670	SMARTwire™ Dual Conductor Socket
14.	1700411	Hex Nut - 5/16"
15.	1701045	Cap Screw - 5/16" x 3/4"
16.	1115385	Heavy-Duty Dual Conductor Plug

Item	Part #	Description
17.	1118437	5-Channel SMARTtransmitter® Battery
	1704597	SMARTtransmitter™ Replacement Battery
18.	1704751	Harness Lock Pin - 1/4" x 7/8"
19.	1704354	40-Amp Modified-Reset Circuit Breaker
20.	1116020	Rocker Switch
21.	1703661	Rocker Switch Mounting Bracket
22.	1703896	Solenoid Cover
23.	1701543	Nylon Lock Nut - 1/4"
24.	1703845	Motor Reversing Solenoid
25.	1700381	Cap Screw - 1/4" x 1"
26.	1700419	Lock Nut - 5/16"
27.	1202938	Rubber Grommet - 1 1/2" Insert
28.	1201237	Flat Washer - 5/16"
29.	_____	Shur-Co® Wireless Receiver - SMARTwire™
30.	1202926	Cap Screw - 5/16" x 7/8"

Our **Advanced Troubleshooting Guide** is available on our website: <http://www.shurco.com>, or call our Help Line: 1-866-748-7435.

PROBLEM:	TRY THIS:
<p>The SMARTransmitter® is not working.</p> <p>I can operate the system with the rocker switch but not with the remote. The SMARTransmitter® channel light (<i>Tarp System</i>, for example) is blinking, and when I press the <i>Open/On</i> button, the light blinks faster.</p>	<ol style="list-style-type: none"> 1. Make sure the remote is set to the right channel. If you cannot set the remote to the desired channel (<i>Tarp System</i>, for example), the remote must be reprogrammed. See the SMARTransmitter® programming instructions. 2. Make sure you are within a couple feet of the receiver and try again. If it works at short range but not at greater distances, you have a range problem. A new battery may be needed. If the remote battery is not the cause, call Shur-Co's Help Line. 3. Reprogram the receiver. See the receiver programming instructions. If this doesn't work, call Shur-Co's Help Line.
<p>The SMARTransmitter® is not working.</p> <p>None of the lights on the remote turn on when I open the lid.</p>	<ol style="list-style-type: none"> 1. Make sure the battery is placed correctly. 2. The battery may be dead and must be replaced. Replacement high-capacity SMARTransmitter® batteries may be purchased from Shur-Co® (P/N 1704597). 3. The SMARTransmitter® may be damaged. Call Shur-Co's Help Line.
<p>The system will not operate with the rocker switch or with the SMARTransmitter®.</p> <p>When I try to use the rocker switch or SMARTransmitter®, I don't hear any noises (a clicking noise, for example) from the receiver.</p>	<ol style="list-style-type: none"> 1. Make sure the master disconnect switch is turned to the "ON" position. 2. The circuit breaker may have tripped. Wait one minute and try again. 3. Check the vehicle's battery to make sure it isn't dead. 4. Check all connections from the battery to the system. Check for polarity, good connections and corrosion. Verify that you have at least 12V on the back side of the receiver on the battery hookup posts. 5. Call Shur-Co's Help Line.
<p>The system will not operate with the rocker switch or with the SMARTransmitter®.</p> <p>When I try to use the rocker switch or SMARTransmitter®, I hear a clicking noise, but nothing happens.</p>	<ol style="list-style-type: none"> 1. Verify that you have at least 12V on the back side of the receiver on the battery hookup posts. 2. Call Shur-Co's Help Line.
<p>The rocker switch is not sticking, but the motor continues to run after I release the rocker switch.</p>	<ol style="list-style-type: none"> 1. Call Shur-Co's Help Line.
<p>The rocker switch is sticking.</p>	<ol style="list-style-type: none"> 1. Check the switch for excessive dirt, rocks or other objects. If the rocker switch cannot be cleaned, call Shur-Co's Help Line for a replacement receiver. The receiver may be pressure washed, but keep nozzle at least 3' from system while spraying.

Our **Advanced Troubleshooting Guide** is available on our website: <http://www.shurco.com>, or call our Help Line: 1-866-748-7435.

MORE QUALITY PRODUCTS FROM SHUR-CO®

- **Genuine Replacement Tarps**
- **Genuine Replacement Parts**

- **Agriculture Products**
 - Value Series Shur-Lok
 - Super Duty Shur-Lok
 - Shur-Lok® Junior
 - Premium Belt 'n Ratchet
 - Cable-Lok™
 - Turning Point™ Bow System

- **SMARTrailer™ Accessories for Agriculture Products**
 - SMARTransmitter®
 - Shur-Link Pro™
 - 4500 Series Electric
 - ProTrap® Hopper Opener
 - LiteALL™ Work Lights
 - Cable-Lok™ Electric Upgrade
 - Electric Turning Point™ Bow System
 - Value Series Electric
 - Solar Power Pack

- **Flatbed Products**
 - Lumber Tarps
 - Steel Tarps
 - Coil Tarps
 - Cargo Control

- **Construction Products**
 - Super Duty Shur-Lok®
 - Premium Belt 'n Ratchet
 - Shur-Trak II™
 - Cover-Pro II®
 - UltraSteel Econo-Pull
 - UltraSteel Arm - Basic
 - UltraSteel Arm - Premium
 - Arm-Matic™
 - Turning Point™ Bow System
 - IronSide™ Side Arm System

- **SMARTrailer™ Accessories for Construction Products**
 - SMARTransmitter®
 - 4500 Series Electric w/Gate Flex™
 - Shur-Trak II™ Electric Upgrade
 - Cover-Pro II® Electric Upgrade
 - Electric Turning Point™ Bow System
 - Solar Power Pack

- **Custom Products**
 - Fitted Truck Covers
 - Flat Utility Tarps
 - Bean Drill Covers
 - Hopper Extension Covers
 - Auger Boots

ENGINEERED TARPING SOLUTIONS

