

Item	Part #	Description
1.	1701243	Splined U-Joint
2.	1700526	Wire Lock Pin - 3/8" x 2 1/2"
3.	1101924	Lock Tube - 5 1/2"
4.	1700443	Spring Pin - 3/8" x 2"
5.	1105001	Shur-Flex™ Upper Crank Extension - 40"
	1105050	Shur-Flex™ Upper Crank Extension - 54"
	1105049	Shur-Flex™ Upper Crank Extension - 96"
6.	1100028	Crank Extension - 80"
7.	1701118	Spring Pin - 1/4" x 1 3/16"
8.	1101921	Male Knuckle
9.	1102691	Lower Extension - 20"
10.	1700418	Centerlock Nut - 3/8"
11.	1700369	Cap Screw - 3/8" x 1 3/4"
12.	1100171	Standard Crank Arm - 24"
13.	1101930	Offset J-Hook Crank Retainer
14.	1100574	Cable w/#5 Interlock Snap
15.	1700400	Self-Tapping Screw - 3/8" x 1"
16.	1700434	Lock Washer - 3/8"
17.	1700407	Hex Nut - 3/8"
18.	1114599	Offset Pinless Crank Retainer Base Plate
19.	1703133	Clevis Pin - 5/16" x 1 3/4"
20.	1703134	Tension Spring
21.	1704380	Bowtie Cotter Pin - 1 3/8"
22.	1700427	Flat Washer - 1/4"
23.	1114600	Offset Pinless Crank Retainer Lock
	1116110	Crank Handle Kit (handle - washer - nut)

STEP 1: Fasten upper crank extension to U-joint. Secure with 3/8" spring pin.

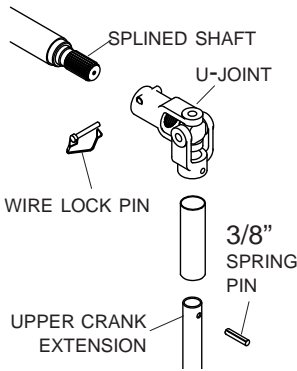

STEP 2: Fasten U-joint to splined shaft on roll tube. Secure with wire lock pin.

STEP 3: Fasten lower crank extension to crank arm. Secure with 3/8" x 1 3/4" cap screw and 3/8" lock nut.

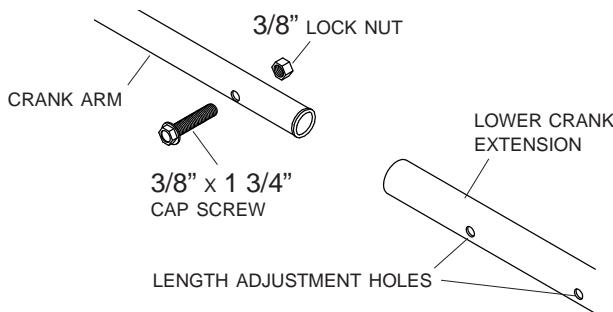

STEP 4: Slide lock tube over upper crank extension and fasten lower crank extension to upper crank extension. Secure with 1/4" spring pin. SEE NOTE.

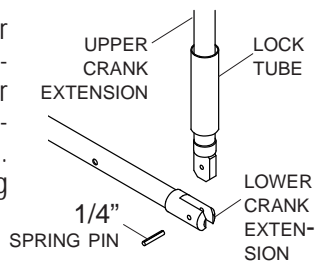

NOTE: If you ordered the Universal Shur-Flex™ Kit, assemble male knuckle to upper crank extension after cutting extension to fit trailer. Fasten male knuckle as shown.

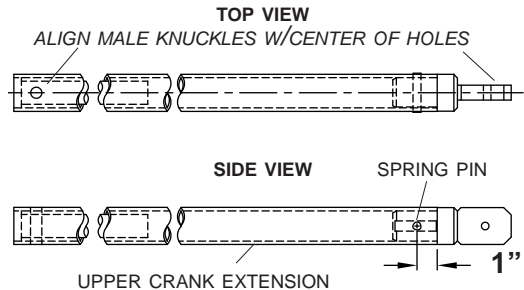

STEP 5: Locate offset crank retainer hooks as shown. Allow room for lock tube to slide so knuckles can bend. Mount retainers with self-tapping screws, lock washers and nuts. Fasten cable with snap between lower lock washer and nut.

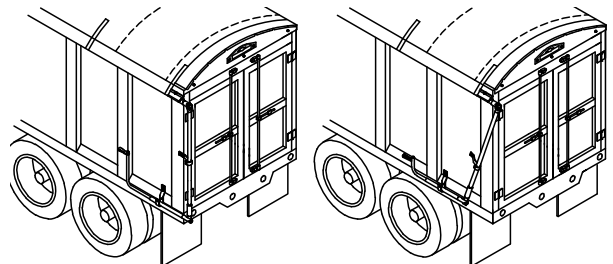

CAUTION Secure lock pins before driving vehicle.

NOTE: To prevent rust, paint all exposed metal, such as weld seams and/or metal exposed by grinding or cutting, with corrosion-resistant paint.