

**NOTE:** To prevent rust, paint all exposed metal, such as weld seams and/or metal exposed by grinding or cutting, with corrosion-resistant paint.

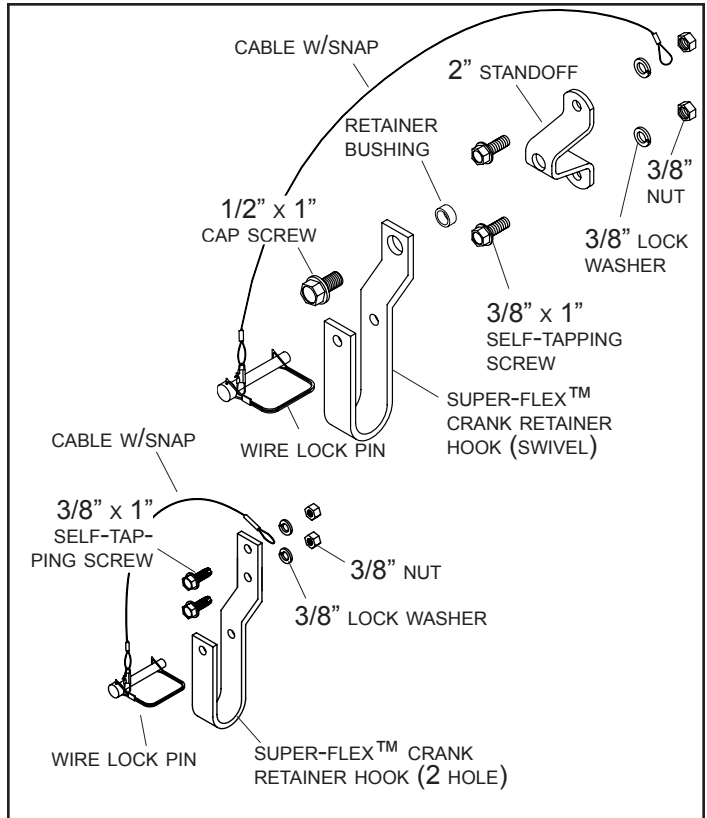

**STEP 1:** Secure upper crank extension to u-joint with 3/8" spring pin.

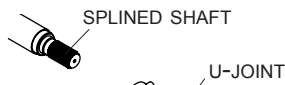

**STEP 2:** Secure U-joint to splined shaft on roll tube with wire lock pin.



**STEP 3:** Secure lower crank extension to crank arm with 3/8" x 1 3/4" cap screw and lock nut.

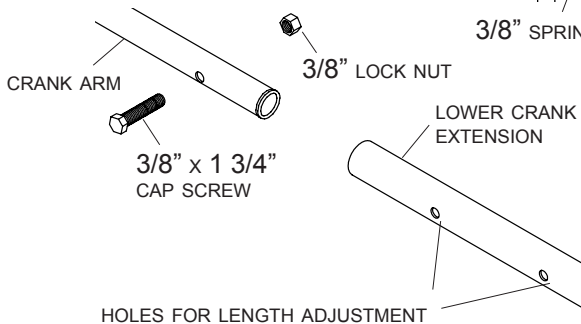
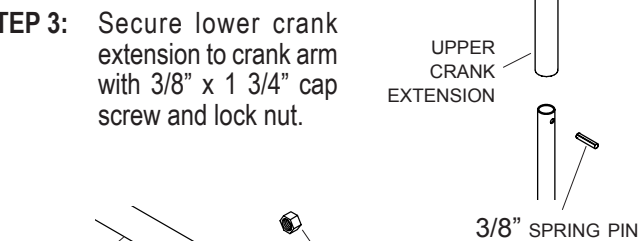

**STEP 4:** Slide lock tube over upper crank extension. Fasten both upper and lower crank extensions to knuckle with 1/4" spring pins.

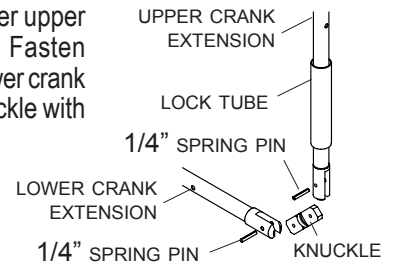

**STEP 5:** Locate Super-Flex™ crank retainer as shown. Allow room for lock tube to slide so knuckle can bend. Mount retainers with self-tapping screws, lock washers and nuts. Attach keeper cord between lower lock washer and nut.

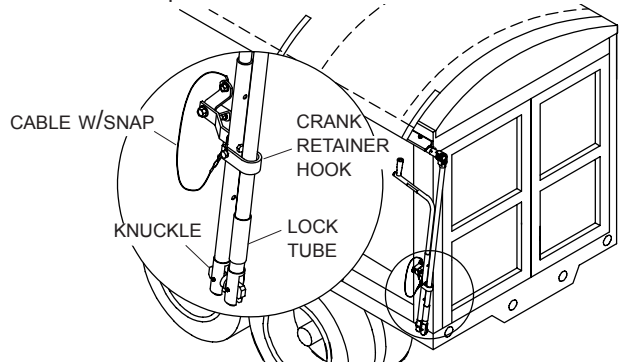

**CAUTION** Secure lock pins before driving vehicle.