

Item	Part #	Description
	1117022	Manual Override Extension Kit
1.	1117020	Manual Override Spline Connector
2.	1117023	Manual Override Spline
3.	1702573	Cap Screw - 3/8" x 2 1/2"
4.	1700418	Centerlock Nut - 3/8"

NOTE: When you are converting your 3500 Electric End Dump System to manual crank operation, you may need to add length to your roll tube. Follow these instructions to lengthen your roll tube.

STEP 1: After Gate Flex™ and flex arm have been removed from rear of trailer, place manual override spline connector over splined shaft on roll tube.

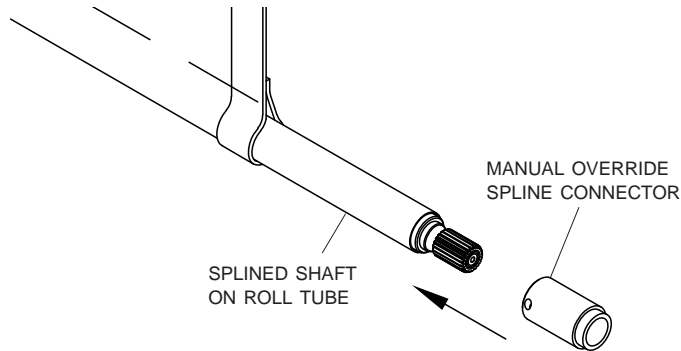

STEP 2: Align manual override spline with roll tube on side of trailer so end of spline extends 3" to 5" past rear of trailer. Mark and cut manual override spline as shown.

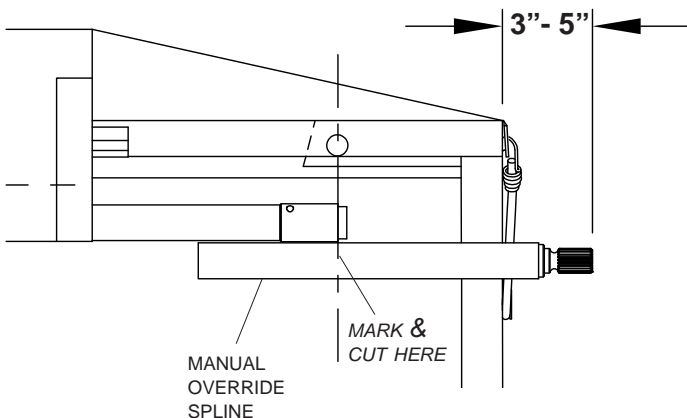

STEP 3: Remove manual override spline connector from roll tube and weld connector to manual override spline. Grind smooth.

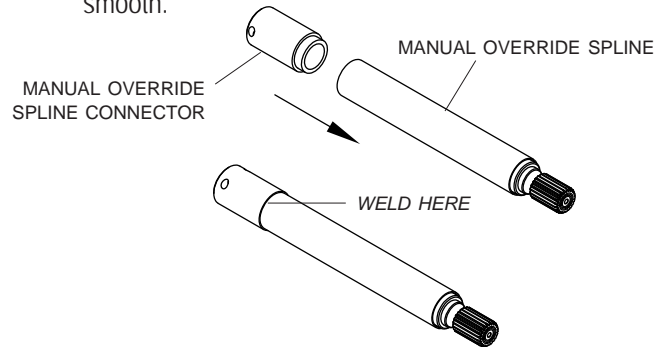

STEP 4: Install manual override extension weldment over splined shaft on roll tube. Secure with 3/8" x 2 1/2" cap screw and 3/8" centerlock nut (from Gate Flex™).

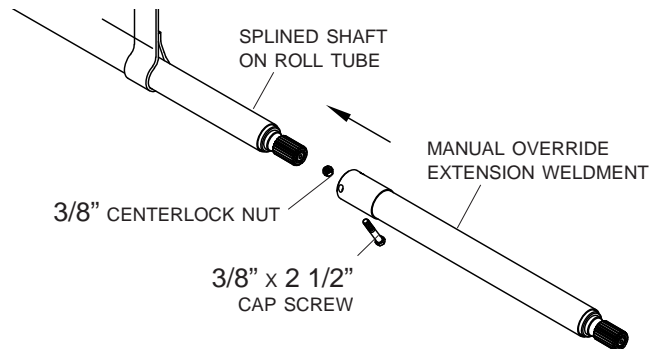

STEP 5: Install crank arm as shown in Shur-Lok® Owner's Manual.

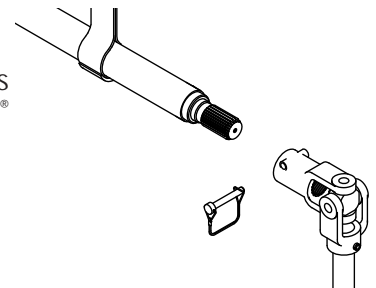

(may be viewed at:
<http://www.shurco.com>)