

Installation Instructions - Auxiliary Stops

P/N 1118334 Rev. B

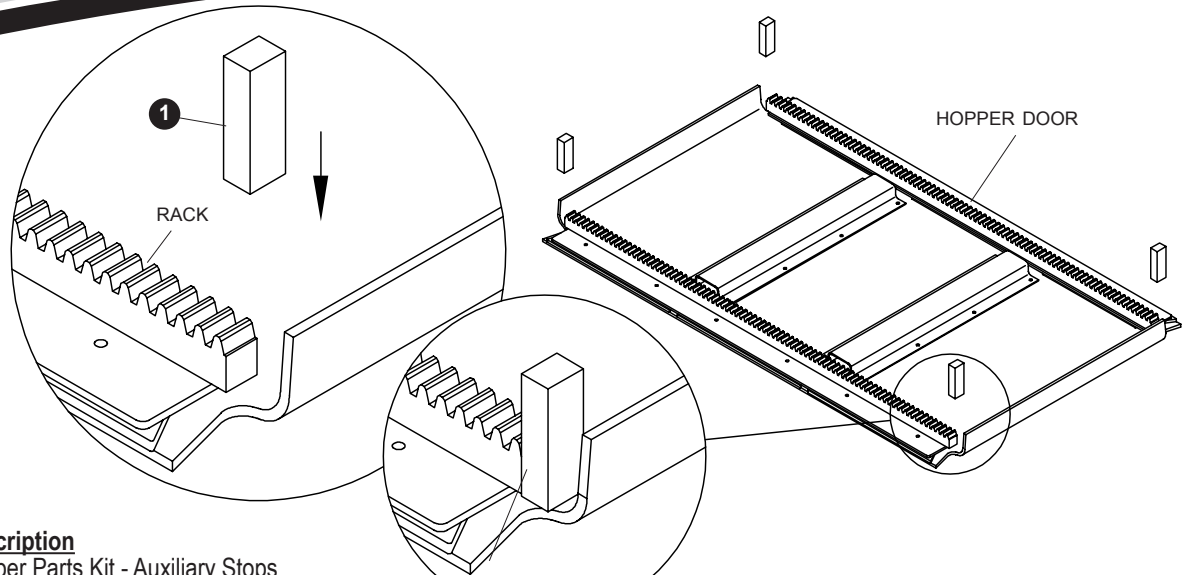

Item	Part #	Description
	1118338	Hopper Parts Kit - Auxiliary Stops
1.	1118307	Door Stop - Auxiliary Stops

LOCATE ALL FOUR DOOR STOPS
AS SHOWN & WELD TO RACK

PO BOX 713 ■ 2309 SHUR-LOK STREET
YANKTON, SOUTH DAKOTA 57078-0713
PH. 1-800-474-8756 ■ FAX 605-665-0501



SHUR-CO.® HELP LINE
CALL: 1-866-748-7435
www.shurco.com

Installation Instructions - Auxiliary Stops

P/N 1118334 Rev. B

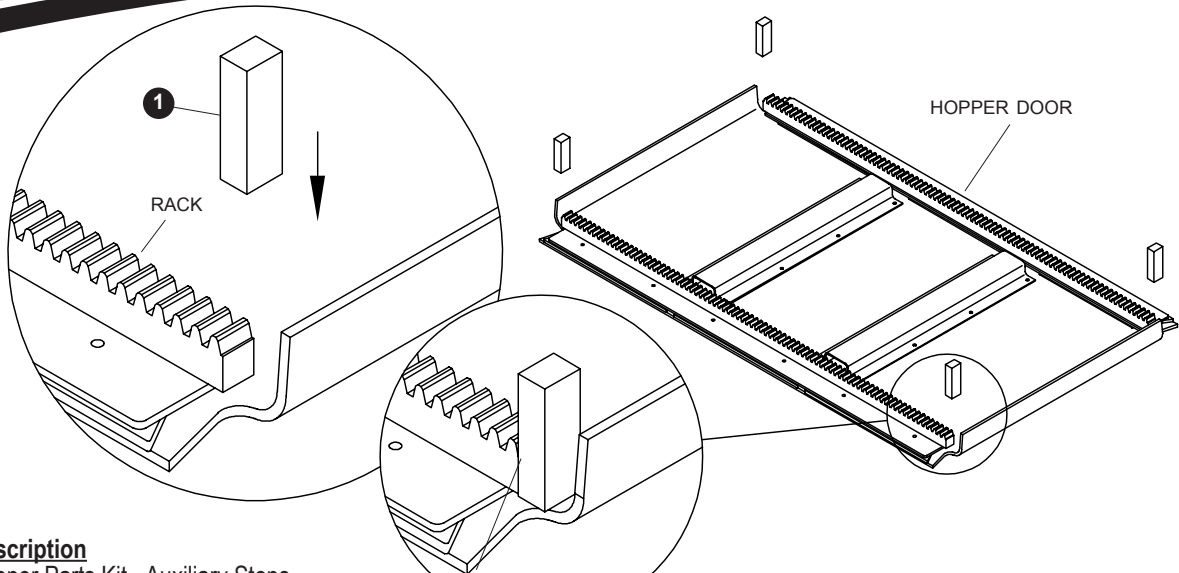

Item	Part #	Description
	1118338	Hopper Parts Kit - Auxiliary Stops
1.	1118307	Door Stop - Auxiliary Stops

LOCATE ALL FOUR DOOR STOPS
AS SHOWN & WELD TO RACK

PO BOX 713 ■ 2309 SHUR-LOK STREET
YANKTON, SOUTH DAKOTA 57078-0713
PH. 1-800-474-8756 ■ FAX 605-665-0501



SHUR-CO.® HELP LINE
CALL: 1-866-748-7435
www.shurco.com