

Item	Part #	Description
	1118339	Hopper Parts Kit - Cornhusker
1.	1118308	Adapter Shaft - Cornhusker

**STEP 1:** Follow instructions in ProTrap® Owner's Manual to determine crank shaft length.

**STEP 2:** After cutting square crank shaft to length, insert adapter shaft 2" into crank shaft, leaving drilled hole exposed as shown.

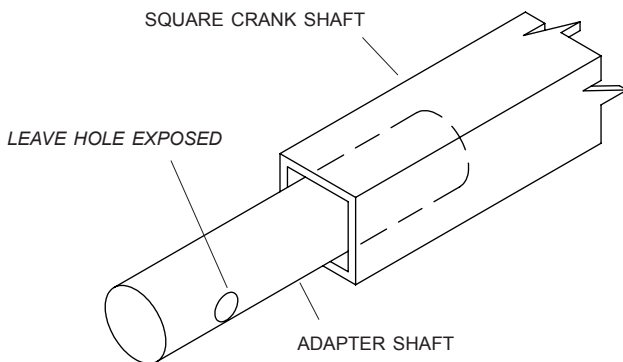

**STEP 3:** Continue following instructions in ProTrap® Owner's Manual until intermediate bracket is fastened to hinge bracket.

**STEP 4:** Insert end of adapter shaft into lower coupling on ProTrap® motor assembly.

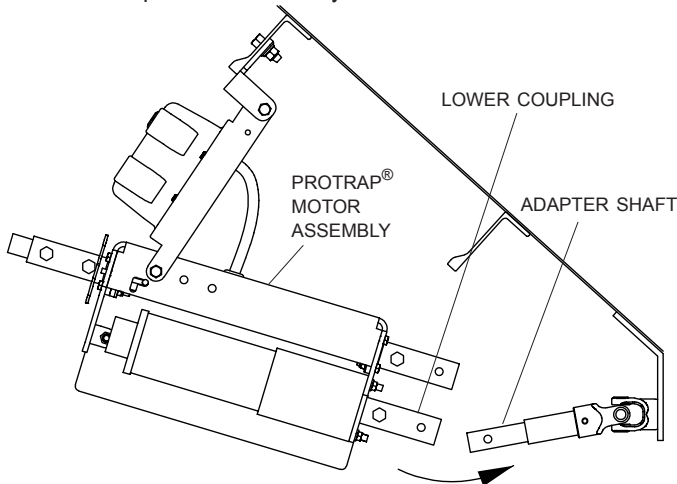

**STEP 5:** Align holes and insert cap screw. Mark weld location on adapter shaft as shown.

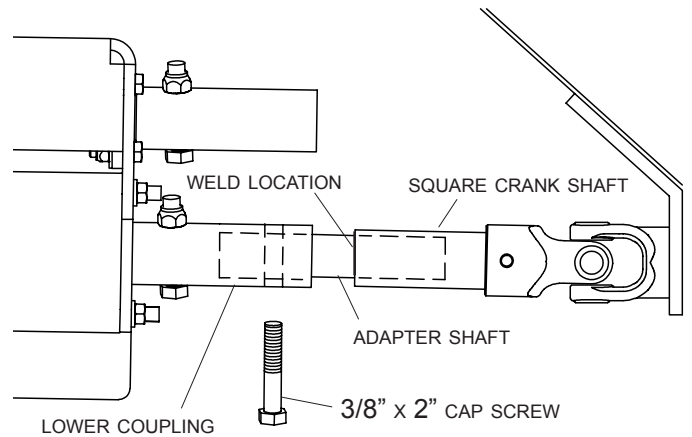

**STEP 6:** Remove cap screw and disengage ProTrap® motor assembly. Align mark on adapter shaft with end of crank shaft. Weld adapter shaft to crank shaft. Repeat Step 4.

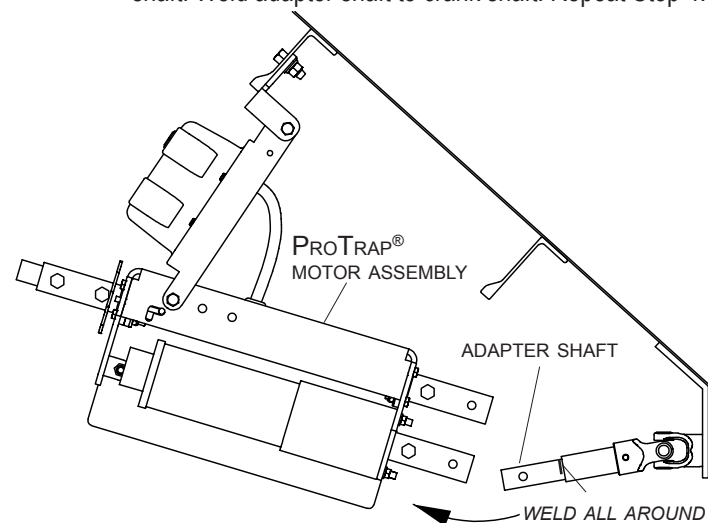

**STEP 7:** Align holes and fasten as shown in manual.

