

Item	Part #	Description
1.	1116922	Sloped Pivot Mount Bracket
2.	1120417	Backer Angle - 2" x 2" x 26"
3.	1702891	Cap Screw - 3/8" x 1 1/4"
4.	1700429	Flat Washer - 3/8"
5.	1700434	Lock Washer - 3/8"
6.	1700407	Hex Nut - 3/8"

- STEP 1:** Determine pivot mount bracket locations according to instructions for sloped trailers in 4500 Owner's Manual.
- STEP 2:** Using pivot mount bracket as a guide, mark and drill 13/32" holes in trailer.

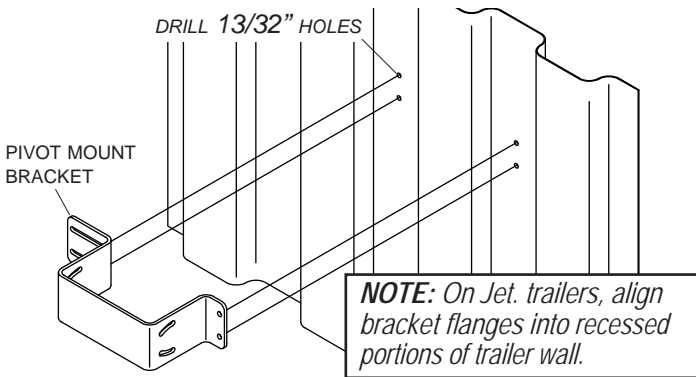

- STEP 3:** Mark and drill four 13/32" holes through backer angles, centering holes on angles in locations shown.

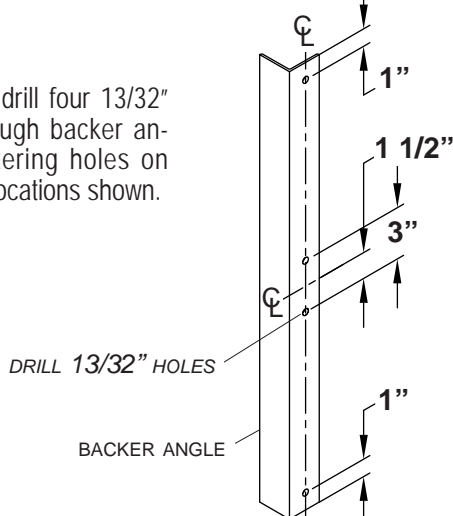

- STEP 4:** Place backer angles inside kingpin, aligning flanges as shown. Place pivot mount bracket on front of trailer and align holes in bracket and angles with holes in trailer. Fasten angles and bracket to trailer with 3/8" x 1 1/4" cap screws, flat washers, lock washers and nuts.

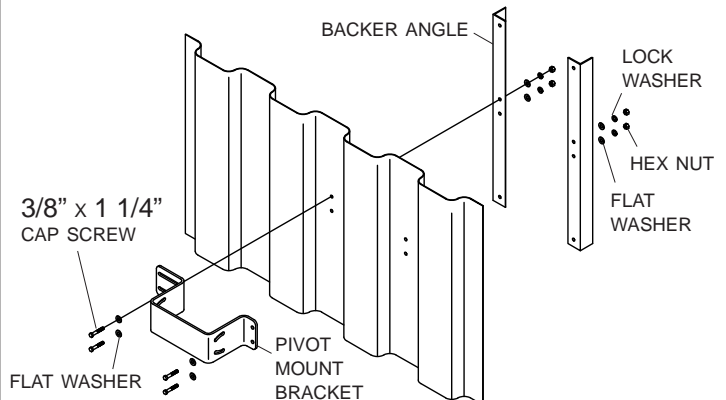

- STEP 5:** Using remaining holes in backer angles as a guide, drill holes in trailer. Fasten angles to trailer with 3/8" x 1" self-tapping screws, flat washers, lock washer and nuts.

