

! WARNING

**DO NOT OPERATE  
MOTORIZED SYSTEMS  
WHILE INDIVIDUALS  
ARE ON OR OCCUPYING  
BOX/TRAILER/HOPPER.**

P/N 1704627

Peel backing and adhere the warning decal shown above to your trailer, placing decal as close to the gray Shur-Co® wireless receiver box as possible. For all cab-operated systems, place decal near rocker switch. Decal must be clearly visible to operators.

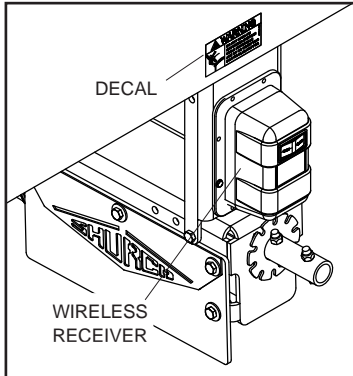
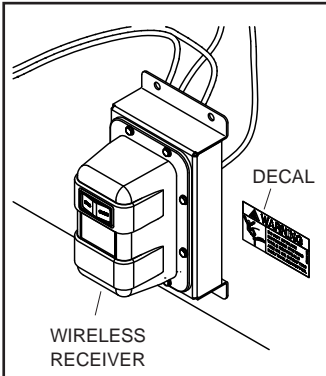

PO BOX 713 ■ 2309 SHUR-LOK STREET  
YANKTON, SOUTH DAKOTA 57078-0713  
PH. 1-800-474-8756 ■ FAX 605-665-0501



SHUR-CO® HELP LINE  
CALL: 1-866-748-7435  
www.shurco.com

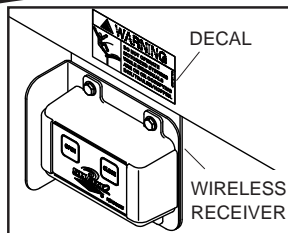

! WARNING

**DO NOT OPERATE  
MOTORIZED SYSTEMS  
WHILE INDIVIDUALS  
ARE ON OR OCCUPYING  
BOX/TRAILER/HOPPER.**

P/N 1704627

Peel backing and adhere the warning decal shown above to your trailer, placing decal as close to the gray Shur-Co® wireless receiver box as possible. For all cab-operated systems, place decal near rocker switch. Decal must be clearly visible to operators.

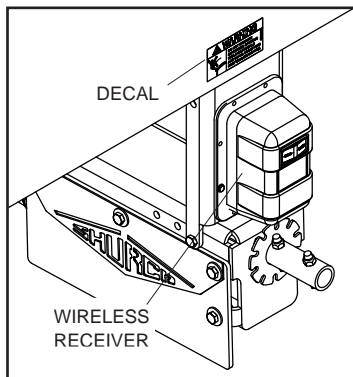
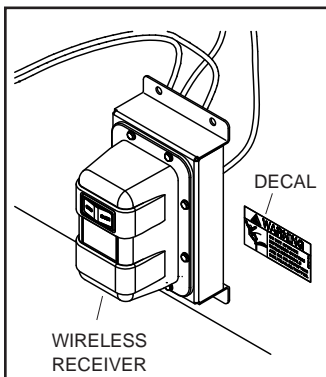

PO BOX 713 ■ 2309 SHUR-LOK STREET  
YANKTON, SOUTH DAKOTA 57078-0713  
PH. 1-800-474-8756 ■ FAX 605-665-0501



SHUR-CO® HELP LINE  
CALL: 1-866-748-7435  
www.shurco.com