



TARPING SYSTEMS & ACCESSORIES

P/N 1120887 Rev. E

INSTALLATION INSTRUCTIONS



Wiring Two ProTraps

READ BEFORE INSTALLING

PO BOX 713 ■ 2309 SHUR-LOK STREET ■ YANKTON, SD 57078-0713
PHONE 1-800-4-SHUR-LOK (1-800-474-8756) ■ FAX 605-665-0501
www.shurco.com

SHOP ONLINE: www.shopshurco.com

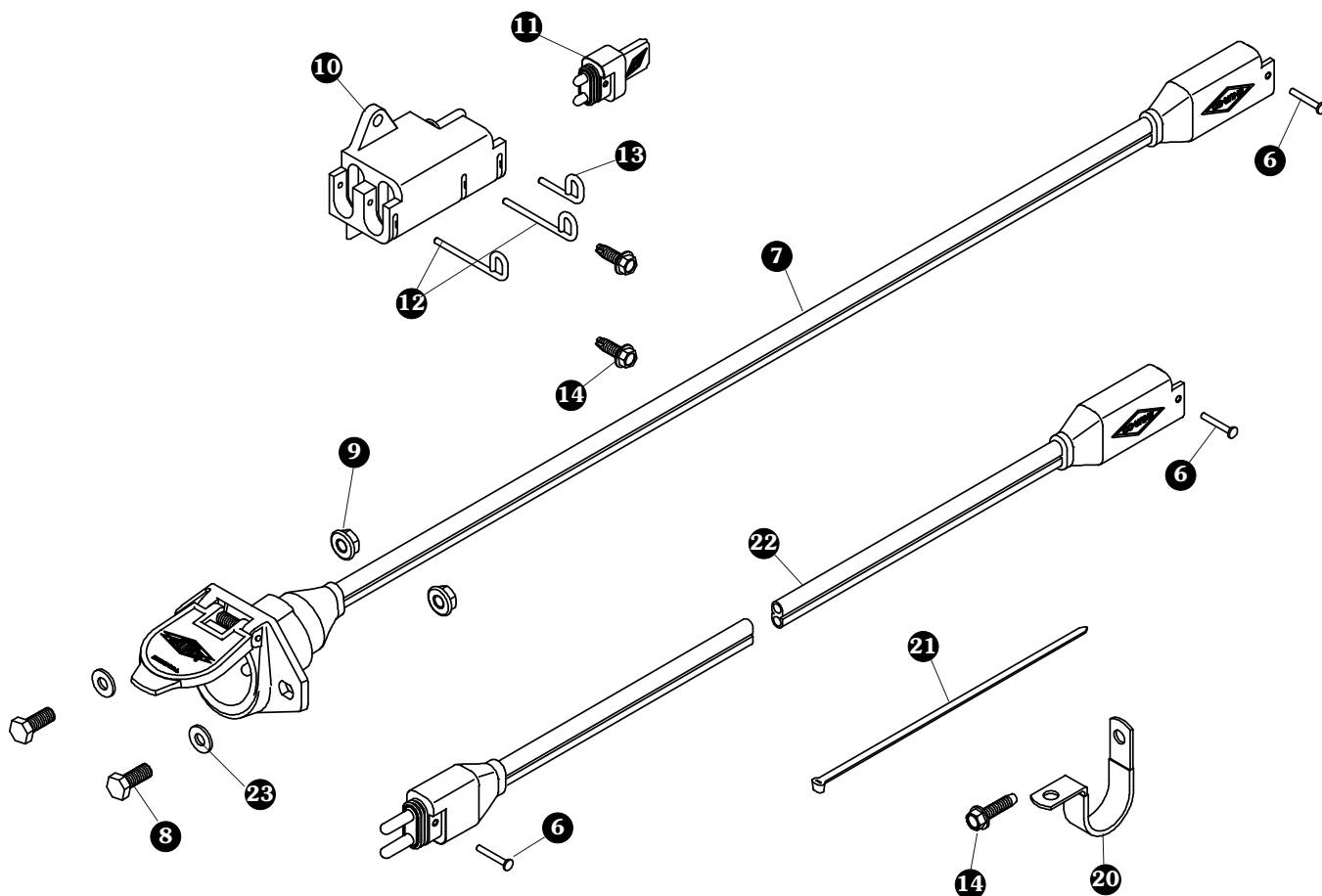

SMARTWIRE™ INSTALLATION

This instruction sheet is supplied with a variety of trailer models, therefore the locations for the SMARTwire™ components shown here may need to vary slightly on your trailer. Mounting locations are critical because wire lengths cannot be altered. Mount SMARTwire™ components as close as possible to the locations shown, not only to ensure a quick and easy installation, but also to facilitate SMARTwire™ upgrades.

Item	Part #	Description
6.	1704751	Harness Lock Pin - 1/4" x 7/8"
7.	1120670	SMARTwire™ Dual Conductor Socket
8.	1701045	Cap Screw - 5/16" x 3/4"
9.	1704946	Flanged Top Lock Nut - 5/16"
10.	1704695	Harness Junction Block
11.	1704717	Wire Harness Rubber Plug
12.	1704696	Harness Lock Pin - Long
13.	1704711	Harness Lock Pin - Short
14.	1704338	Self-Tapping Screw - 1/4" x 1"
20.	1702108	Wire Clip - 3/4"
21.	1703231	Cable Tie - 8"
22.	1704704	SMARTwire™ - 6 Ga. x 25' - Plug/Socket
23.	1700427	Flat Washer - 1/4"

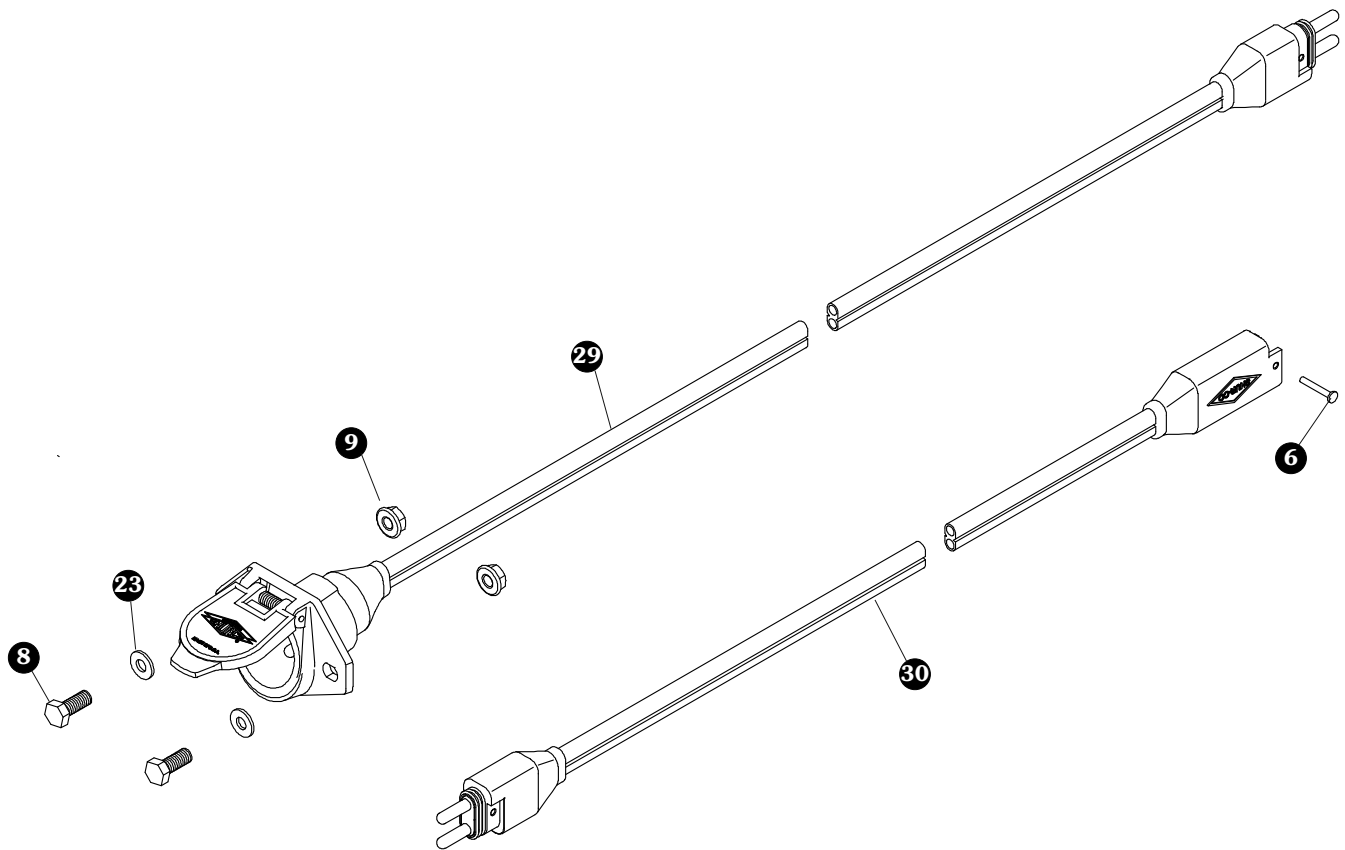

**LEAD TRAILER WIRING PARTS FOR SUPPLYING
POWER TO REAR/PUP TRAILERS**

Item	Part #	Description
6.	1704751	Harness Lock Pin - 1/4" x 7/8"
8.	1701045	Cap Screw - 5/16" x 3/4"
9.	1704946	Flanged Top Lock Nut - 5/16"
23.	1700427	Flat Washer - 1/4"
29.	1122541	SMARTwire™ - 4 Ga. x 22' - Dual-Conductor Socket
	1122542	SMARTwire™ - 4 Ga. x 32' - Dual-Conductor Socket
	1122543	SMARTwire™ - 4 Ga. x 40' - Dual-Conductor Socket
30.	1704888	SMARTwire™ - 4 Ga. x 25' - Plug/Socket

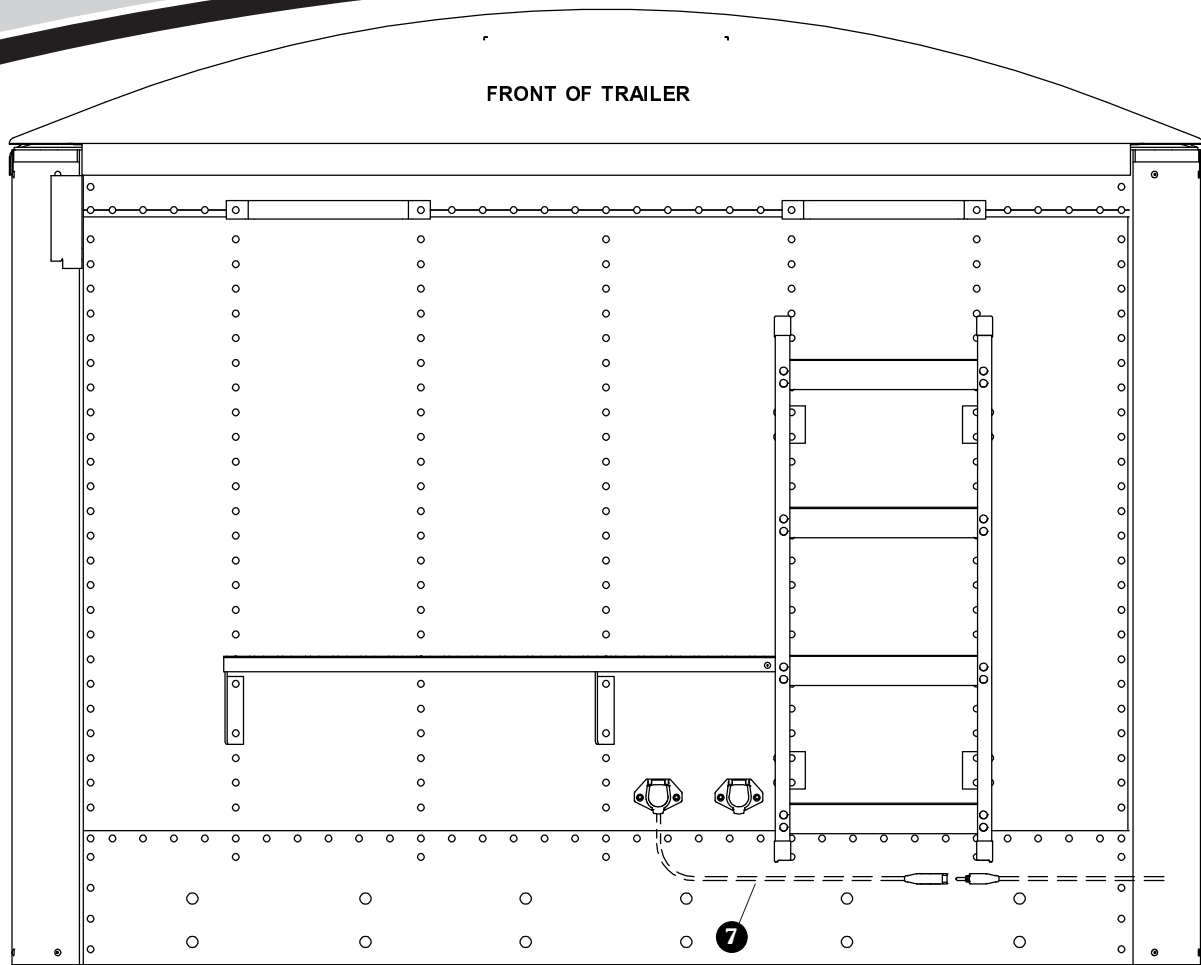

NOTE: Wire lengths are predetermined. Before installing SMARTwire™ components, review and confirm wire routing so that wires will reach components with ample room for connection.

DUAL-POLE CONDUCTOR SOCKET INSTALLATION

STEP 1: Locate dual-pole conductor socket near seven-pole conductor socket as shown. Determine location and drill 2" hole through trailer skin.

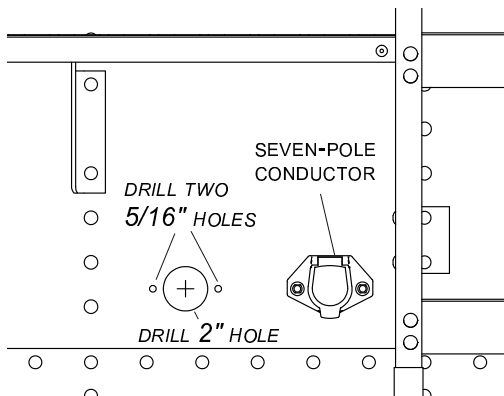

STEP 2: Align socket over 2" hole. Using holes in flanges on socket as a guide, mark and drill two 5/16" holes.

STEP 3: Fasten conductor socket to trailer with 5/16" x 3/4" cap screws, flat washers and nuts.

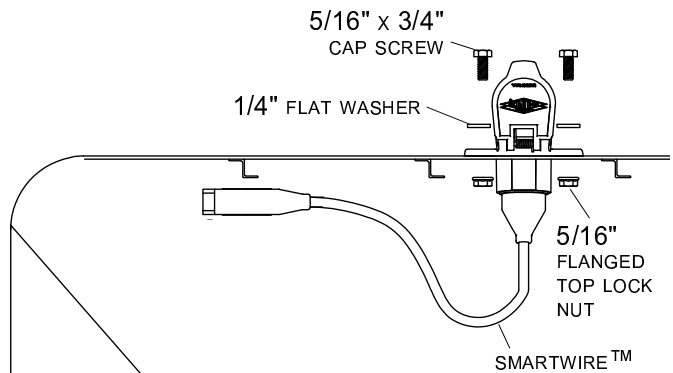

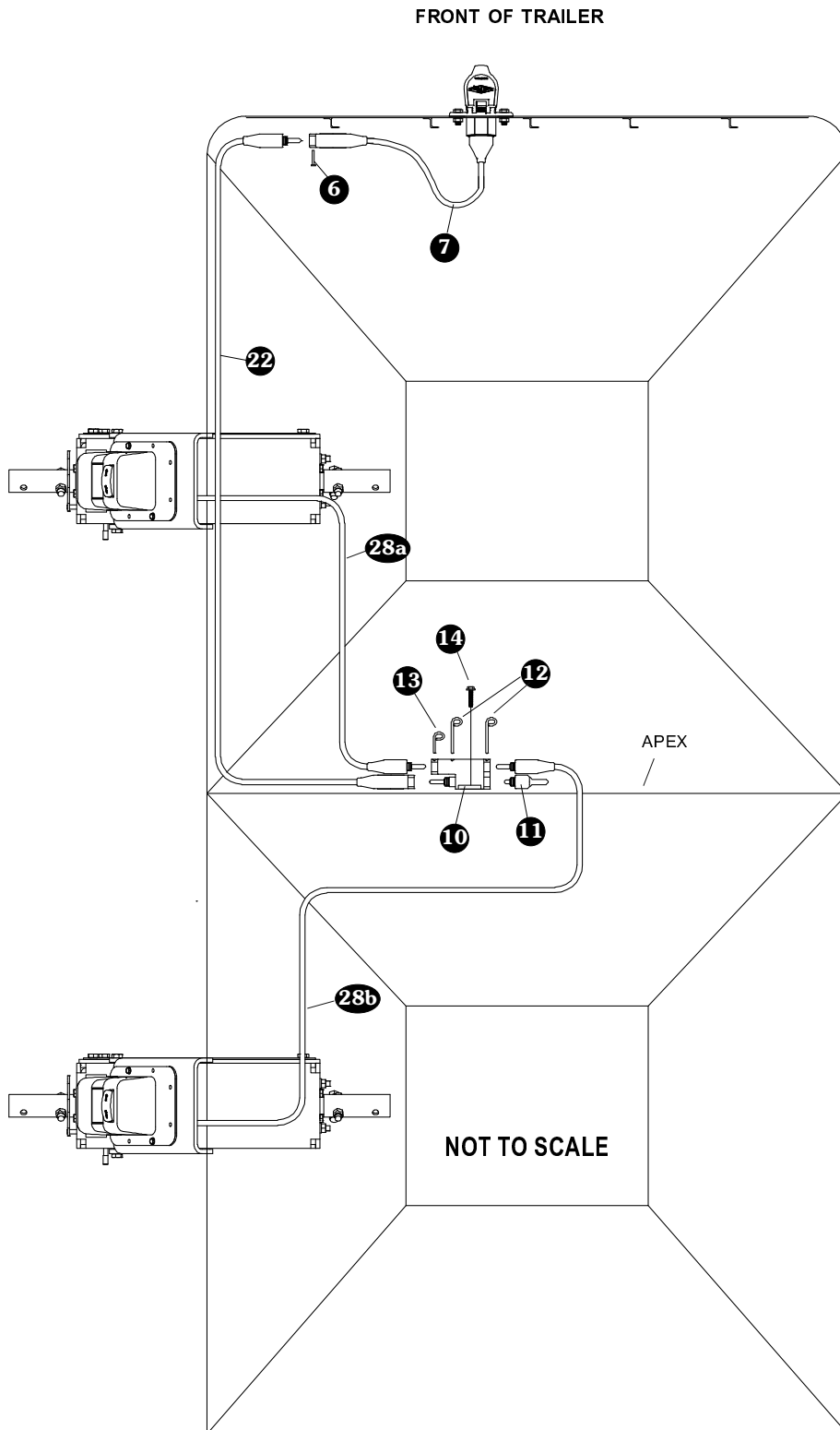

NOTE: Coat each connection with dielectric grease (P/N 1704378) to prevent corrosion.

CAUTION
Do not fasten SMARTwire™ components to trailer through hopper walls.

FRONT OF TRAILER

- STEP 1:** Route SMARTwire™ 7 along existing wiring on trailer.
- STEP 2:** Plug SMARTwire™ 22 into SMARTwire™ 7 and secure connection with lock pin 6. Route smart wire 22 to apex on trailer.

APEX OF TRAILER

- STEP 3:** To determine junction block location, route SMARTwires 22, 23a and 23b to location on apex where wires will reach. Position junction block 10 at this location. Using holes in junction block as a guide, mark and drill two 7/32" holes.
- STEP 4:** Fasten junction block 10 to trailer with screws 14.
- STEP 5:** Insert plug 11 into junction block 10. Connect SMARTwires 22, 23a and 23b to junction block 10.
- STEP 6:** Secure SMARTwires 22, 23a and 23b to junction block with lock pins 12 and 13.
- STEP 7:** Secure all wires to trailer with cable clips 20 and screws 14. If needed, use cable ties 21.

NOTE: For lead/pup trailer configurations, continue on next page.

NOTE: Coat each connection with dielectric grease (P/N 1704378) to prevent corrosion.

CAUTION
Do not fasten SMARTwire™ components to trailer through hopper walls.

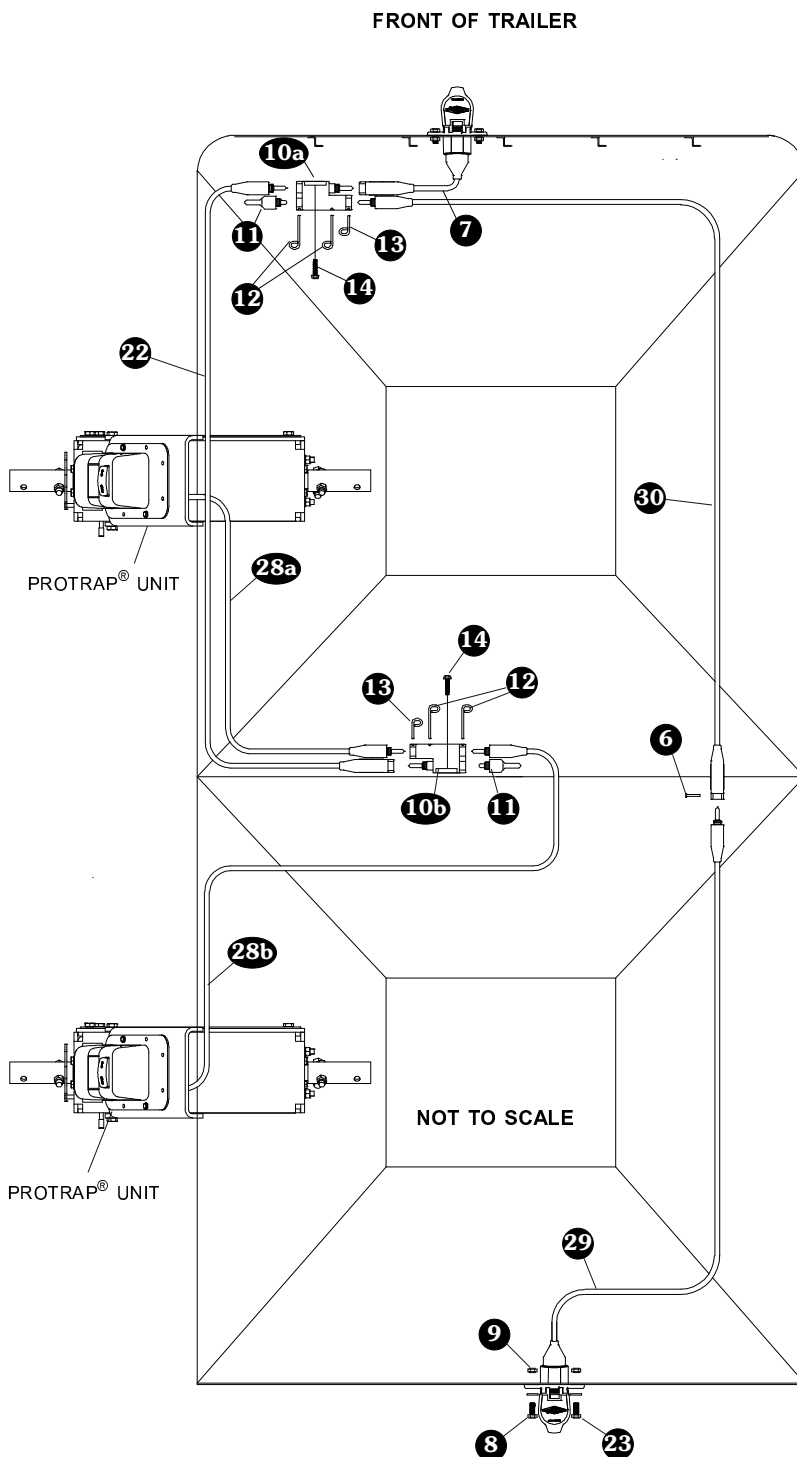

FRONT OF TRAILER

- STEP 1:** Remove lock pin 6 from SMARTwire™ 7. Disconnect wires.
- STEP 2:** To determine junction block location on front of trailer, route SMARTwires 7, 22 and 30 to where wires will meet. Position junction block 10a at this location. Using holes in junction block as a guide, mark and drill two 7/32" holes.
- STEP 3:** Fasten junction block 10a to trailer with screws 14.
- STEP 4:** Connect SMARTwires 7 and 22 and 30 to junction block 10a, then insert plug 11. Secure with lock pins 12 and 13.

REAR OF TRAILER

- STEP 5:** To determine location for conductor socket 29 on rear of trailer, route SMARTwire™ 30 and SMARTwire™ from conductor socket 29 to location near middle of trailer, where wires will reach. Mount conductor socket at this location.
- STEP 6:** Follow steps 1 to 3 on page 3 to install conductor socket 29.

MIDDLE OF TRAILER

- STEP 7:** Connect SMARTwires 30 and 29. Secure with lock pin 6.
- STEP 8:** Secure all wires to trailer with cable clips 20 and screws 14. If needed, use cable ties 21.

MORE QUALITY PRODUCTS FROM SHUR-CO®

- **Genuine Replacement Tarps**
- **Genuine Replacement Parts**

- **Agriculture Products**
 - Value Series Shur-Lok®
 - Super Duty Shur-Lok®
 - Shur-Lok® Junior
 - Premium Belt 'n Ratchet
 - Cable-Lok™
 - Turning Point™ Bow

- **SMARTrailer™ Accessories for Agriculture Products**
 - SMART2™ Remote
 - SMART1 +™ Remote
 - 4500 Series HD Electric
 - AutoTrap™ Hopper Opener
 - ProTrap® Hopper Opener
 - LiteALL™ Work Lights
 - Cable-Lok™ Electric Upgrade
 - Electric Turning Point™ Bow
 - Value Series Electric
 - Solar Power Pack

- **Flatbed Products**
 - ShurTite™ Retractable Tarps
 - Stock Lumber & Steel Tarps
 - Steel Tarps

- **Custom Products**
 - Fitted Truck Covers
 - Flat Utility Tarps
 - Bean Drill Covers
 - Shur-Lok® Tarp Cords

- **Construction Products**
 - Super Duty Shur-Lok®
 - Shur-Trak II™
 - Cover-Pro II®
 - Turning Point™ Bow
 - IronSide™ Side-Dump System
 - Arm-Matic™
 - DuraPull™
 - Econo-Pull™
 - Turbo Tarp2 DONOVAN BRAND
 - 2000 Series DONOVAN BRAND
 - 5000 Series DONOVAN BRAND
 - Hammer DONOVAN BRAND
 - Bullet DONOVAN BRAND
 - Flash DONOVAN BRAND
 - Long Arm DONOVAN BRAND

- **SMARTrailer™ Accessories for Construction Products**
 - 4500 Series HD Electric w/Gate Flex™
 - Shur-Trak II™ Electric Upgrade
 - Cover-Pro II® Electric Upgrade
 - Electric Turning Point™ Bow
 - Solar Power Pack

- **Waste Products DONOVAN BRAND**
 - The Ox™
 - Quick-Flip III
 - Sidewinder
 - Sidewinder 350
 - HyTower SL
 - HyTower DL
 - Double-Flip