



ProTrap® Wiring

INSTALLATION INSTRUCTIONS

Triple ProTrap®



PHONE: 1.866.748.7435 | FAX: 1.605.665.0501
2309 SHURLOCK STREET | YANKTON, SD 57078-0713

SHURCO.com



SAFETY INSTRUCTIONS

At Shurco, your safety is our top priority. Please read and thoroughly understand all instructions before operating all equipment. Failure to READ AND FOLLOW INSTRUCTIONS may result in system failure, property damage, or personal injury. Pay close attention to warnings, cautions, and operating instructions. The hazard symbol  alerts users of potentially hazardous conditions, and is followed by Caution, Warning, or Danger messages to indicate risk:

- **Danger:** (red) Indicates an imminently hazardous situation that, if not avoided, WILL result in death or serious injury.
- **Warning:** (orange) Indicates a potentially hazardous situation that, if not avoided, COULD result in death or serious injury.
- **Caution:** (yellow) Indicates a potentially hazardous situation that, if not avoided, MAY result in minor or moderate injury, or damage to the system.
- **Notice:** (blue) Indicates operational notes or other essential information without addressing safety.

Regularly inspect equipment to ensure proper performance. Always repair or replace worn or damaged parts immediately to maintain safety. Safety decals are placed at critical locations on equipment. Keep these decals clean and legible at all times. Replace any decal that is worn, damaged, painted over or otherwise unreadable. Replacement decals can be obtained by your local Shurco dealer.

- Always wear safety glasses during installation and operation.
- Stay clear of moving parts.
- No other use of Shurco equipment is authorized, except as designed.

SHUR-CO, LLC TERMS OF SERVICE

ORDER
TERMS AND CONDITIONS



WARRANTY



PATENTS



QUESTIONS?

CALL OUR HELP LINE:

1-866-748-7435

MONDAY-FRIDAY
8 AM-5 PM CENTRAL TIME

VEHICLE ORIENTATION

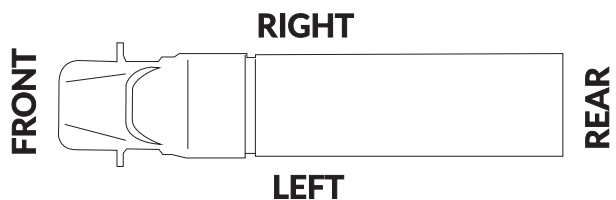

⚠ WARNING

Failure to disconnect power before performing wiring may result in equipment damage, serious injury, or death.

- Disconnect power before performing any wiring or service.
- This installation instructions is a supplement; follow all warnings, cautions, and procedures in the owner's manual.

NOTICE: This instruction sheet is supplied with a variety of trailer models, therefore the locations for the SMARTwire components shown here may vary slightly on your trailer. Mounting locations are critical because wire lengths cannot be altered. Mount SMARTwire components as close as possible to the locations shown.

⚠ CAUTION

- Do not cut molded SMARTwire ends. Molded SMARTwire ends are designed with sealed connections to prevent corrosion; cutting the wire may lead to operational problems.
- Bind excess wire with cable ties to prevent loose wire entanglement.

Item	Part #	Description
6.	1704751	Harness Lock Pin - 1/4" x 7/8" (included with ProTrap kit)
7.		SMARTwire - Dual-Conductor Socket (not pictured, included with ProTrap kit)
10.	1704695	Harness Junction Block
11.	1704717	Wire Harness Rubber Plug
12.	1704696	Harness Lock Pin - Long
13.	1704711	Harness Lock Pin - Short
14.	1704338	Self-Tapping Screw - 1/4" x 1"
20.	1702108	Wire Clip - 3/4"
21.	1703231	Cable Tie - 8"
22.	1704704	SMARTwire™ - 6 Ga. x 25' - Plug/Socket
28.	1704827	SMARTwire™ - 6 Ga. x 16' - Plug/Socket
	1704378	Dielectric Connector Protector (not pictured)

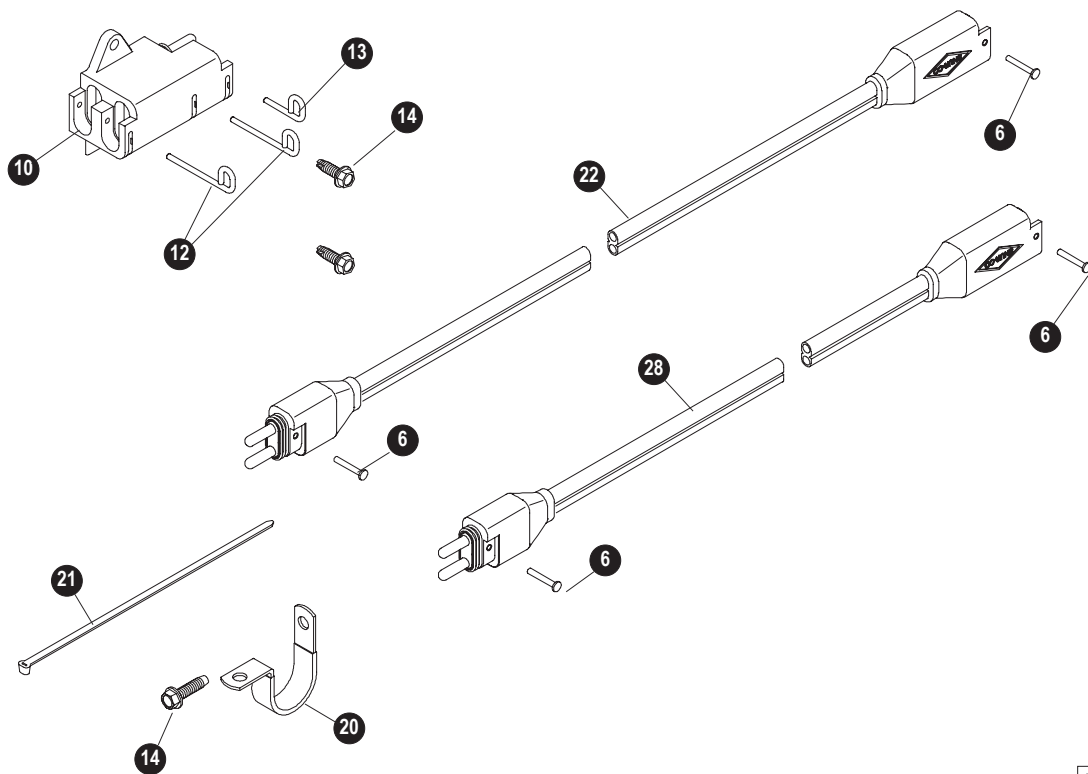
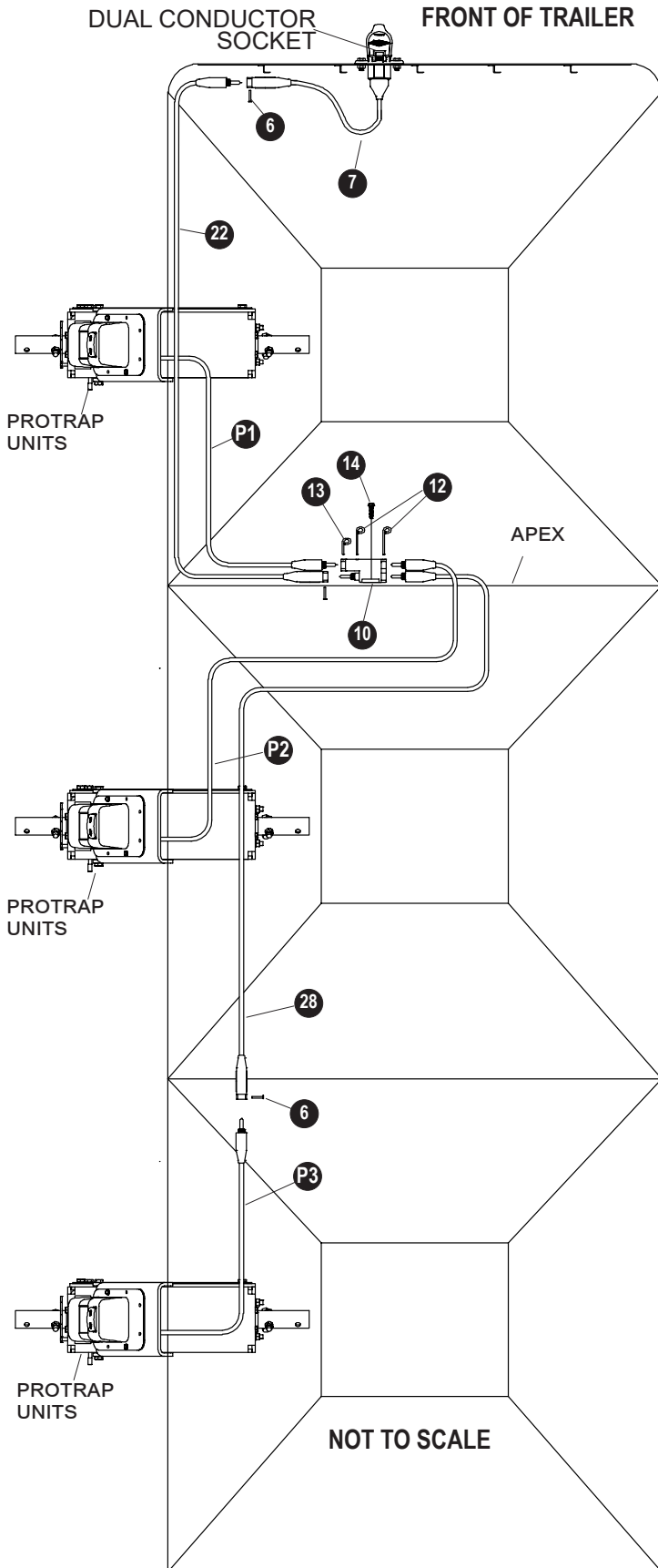

IMAGE 101



NOTICE: Coat each connection with dielectric grease (P/N 1704378) to prevent corrosion.

CAUTION
Do not fasten SMARTwire components to the trailer through the hopper walls. Doing so may damage the hopper walls or compromise system performance.

FRONT OF TRAILER

- STEP 1:** Route SMARTwire dual conductor socket (7) along existing wiring on trailer.
- STEP 2:** Plug SMARTwire (22) into SMARTwire (7) and secure connection with lock pin (6). Route SMARTwire (22) to apex on trailer.

APEX OF TRAILER

- STEP 3:** To determine junction block (10) location, route SMARTwire (22) and ProTrap wires (P1) and (P2) to location on apex where wires will reach. Position junction block (10) at this location. Using holes in junction block as a guide, mark and drill two 7/32-inch holes.
- STEP 4:** Fasten junction block (10) to trailer with screws (14).
- STEP 5:** Connect SMARTwires (22), (P1) (P2) and (28) to junction block (10).
- STEP 6:** Secure SMARTwires to junction block with lock pins (12) and (13).
- STEP 7:** Route SMARTwire (28) toward rear of trailer and connect to rear ProTrap SMARTwire (P3). Secure with lock pin (6).
- STEP 8:** Secure all wires to trailer with cable clips (20) and screws (14). If needed, use cable ties (21).

NOTICE: For lead/pup trailer configurations, continue on next page.

IMAGE 111

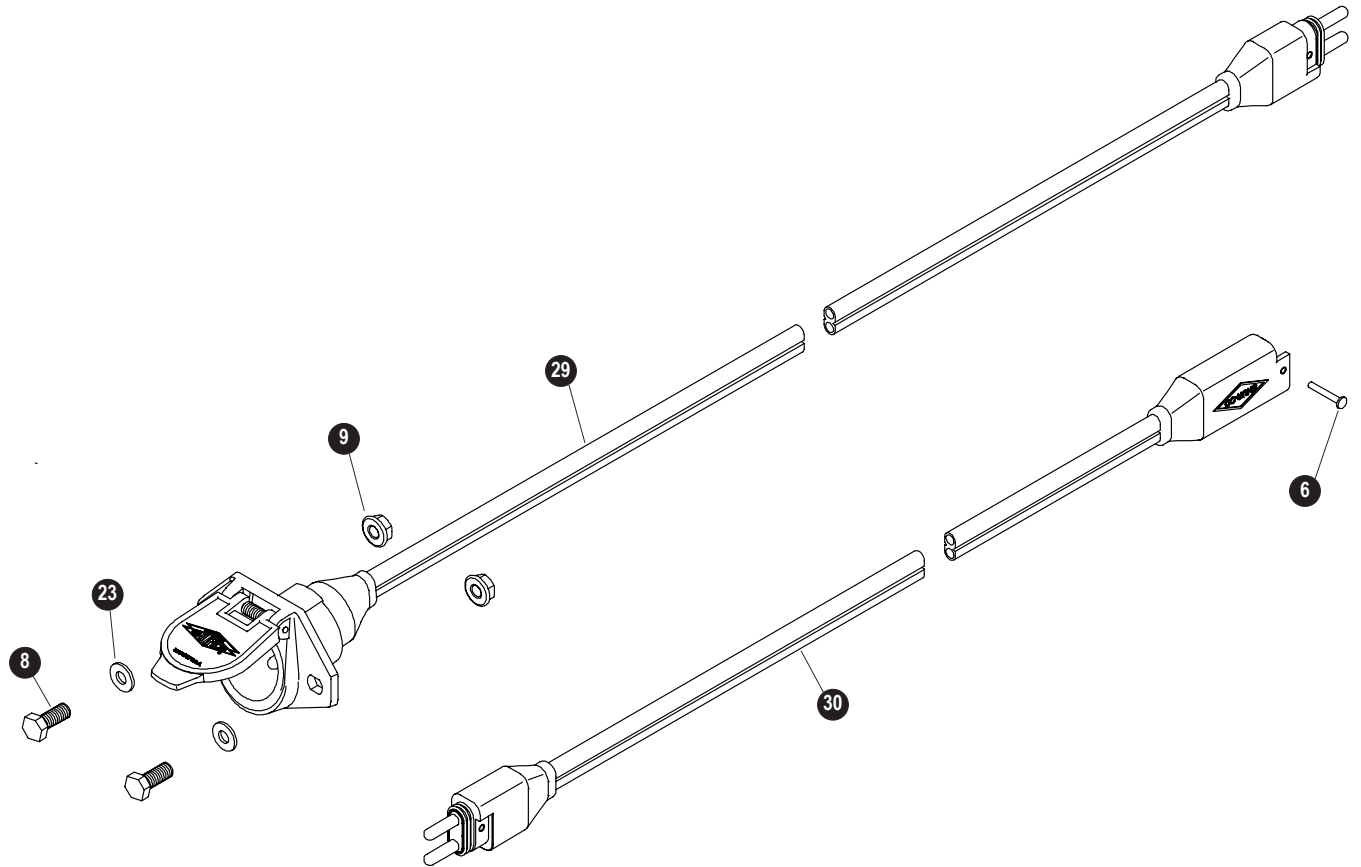

IMAGE 103

LEAD TRAILER WIRING PARTS FOR SUPPLYING POWER TO REAR/PUP TRAILERS

Item	Part #	Description
6.	1704751	Harness Lock Pin - 1/4" x 7/8"
8.	1701045	Cap Screw - 5/16" x 3/4"
9.	1704946	Flanged Top Lock Nut - 5/16"
23.	1700427	Flat Washer - 1/4"
29.	1122541	SMARTwire™ - 4 Ga. x 22' - Dual-Conductor Socket
	1122542	SMARTwire™ - 4 Ga. x 32' - Dual-Conductor Socket
	1122543	SMARTwire™ - 4 Ga. x 40' - Dual-Conductor Socket
30.	1704888	SMARTwire™ - 4 Ga. x 25' - Plug/Socket

⚠ CAUTION

- Do not cut molded SMARTwire ends. Molded SMARTwire ends are designed with sealed connections to prevent corrosion; cutting the wire may lead to operational problems.
- Bind excess wire with cable ties to prevent loose wire entanglement.

NOTICE: Coat each connection with dielectric grease (P/N 1704378) to prevent corrosion.

CAUTION

Do not fasten SMARTwire components to the trailer through the hopper walls. Doing so may damage the hopper walls or compromise system performance.

NOTICE: Complete all wiring shown in the first schematic (page 4) before proceeding with pup wiring.

FRONT OF TRAILER

- STEP 1:** Remove lock pin (6) from SMARTwire (7). Disconnect wires.
- STEP 2:** To determine junction block location on front of trailer, route SMARTwires (7), (22), and (30) to where wires will meet. Position junction block (10a) at this location. Using holes in junction block as a guide, mark and drill two 7/32-inch holes.
- STEP 3:** Fasten junction block (10a) to trailer with screws (14).
- STEP 4:** Connect SMARTwires (7), (22), and (30) to junction block (10a), then insert plug (11). Secure with lock pins (12) and (13).

REAR OF TRAILER

- STEP 5:** To determine location for conductor socket (29) on rear of trailer, route SMARTwire (30) and SMARTwire from conductor socket (29) to location near middle of trailer, where wires will reach. Mount conductor socket at this location.
- STEP 6:** Follow steps 1 to 3 on page 7 to install conductor socket (29).

MIDDLE OF TRAILER

- STEP 7:** Connect SMARTwires (30) and (29). Secure with lock pin (6).
- STEP 8:** Secure all wires to trailer with cable clips (20) and screws (14). If needed, use cable ties (21).

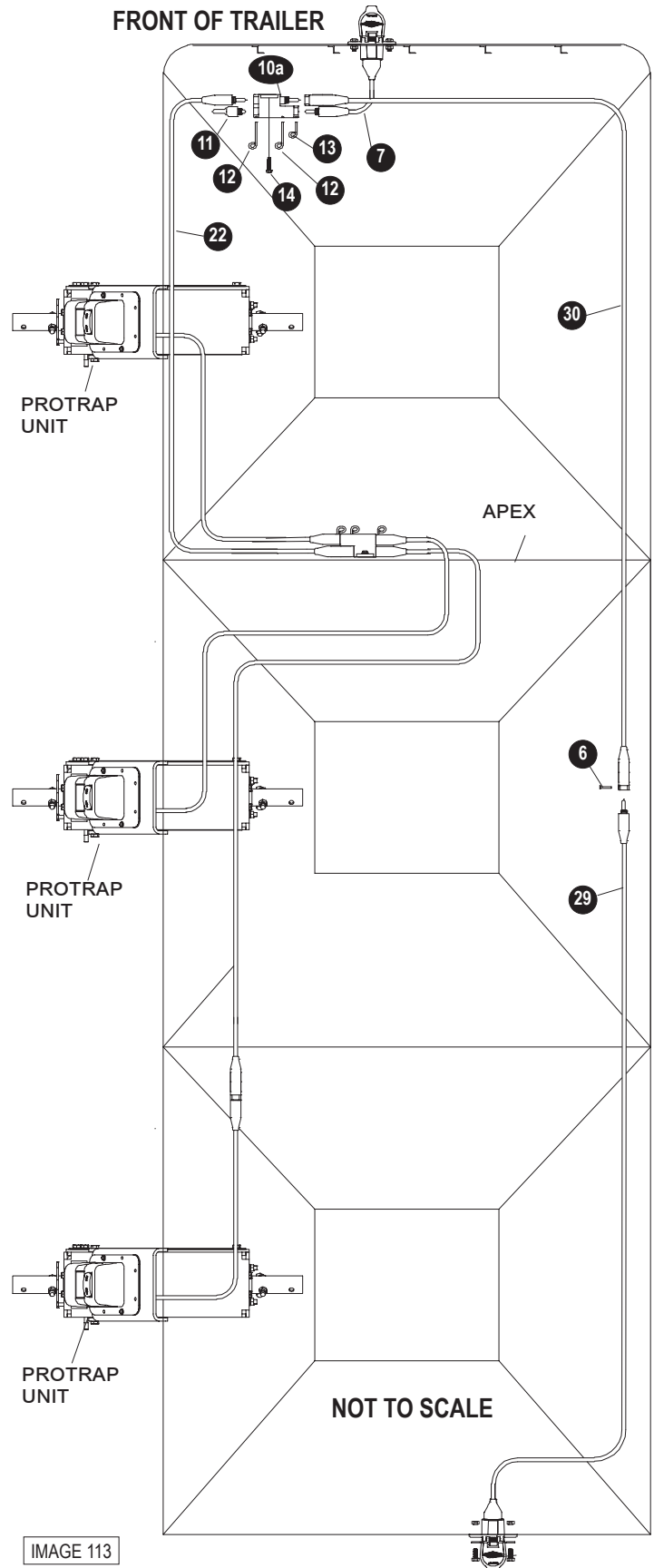
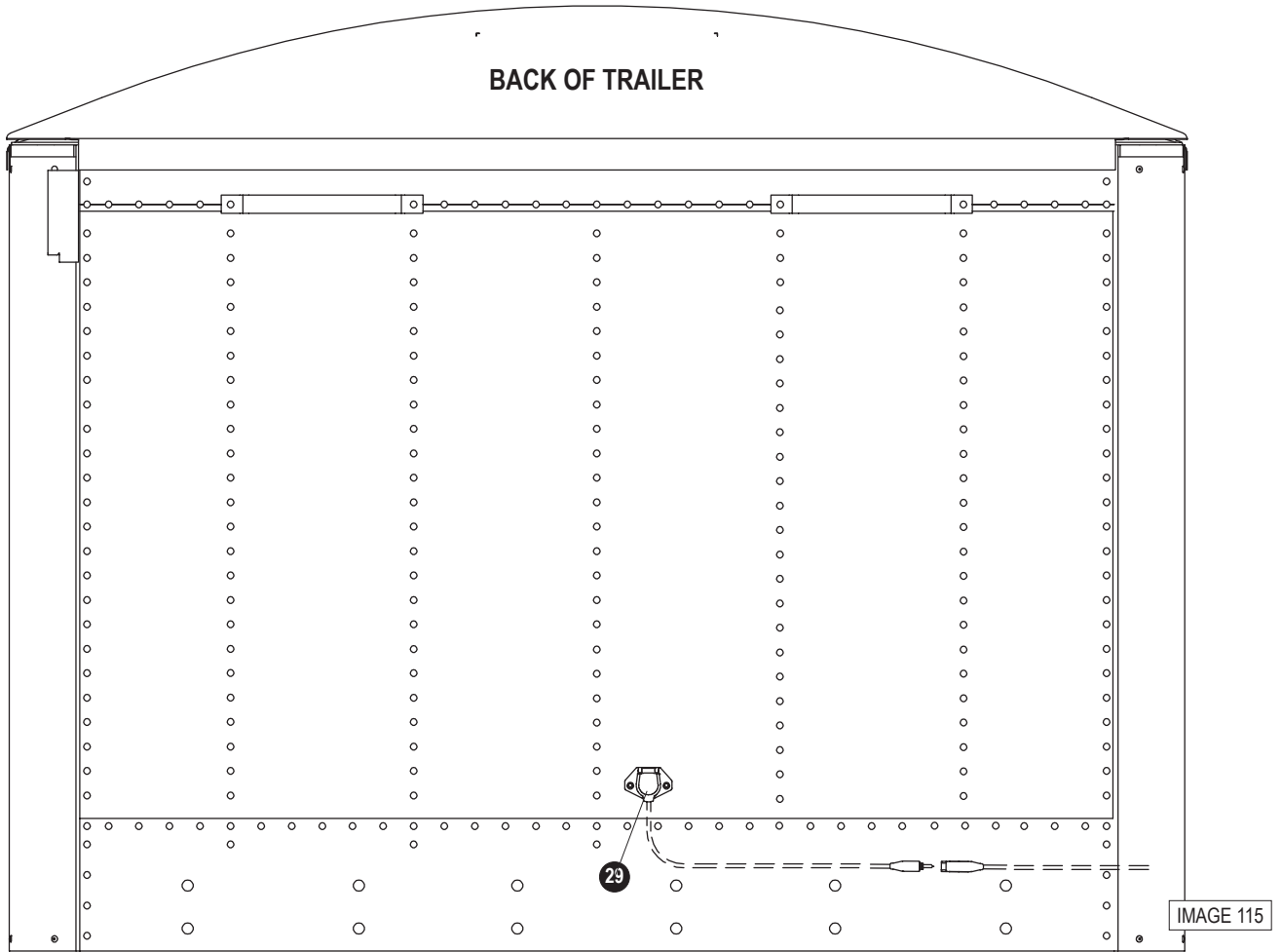

IMAGE 113



NOTICE: Wire lengths are predetermined. Before installing SMARTwire components, review and confirm wire routing so that wires will reach components with ample room for connection.

DUAL-POLE CONDUCTOR SOCKET INSTALLATION

- STEP 1:** Locate the dual-pole conductor socket in the center of the trailer. Determine location and drill 2-inch hole through trailer skin.
- STEP 2:** Align socket over 2-inch hole. Using holes in flanges on socket as a guide, mark and drill two 5/16" holes.

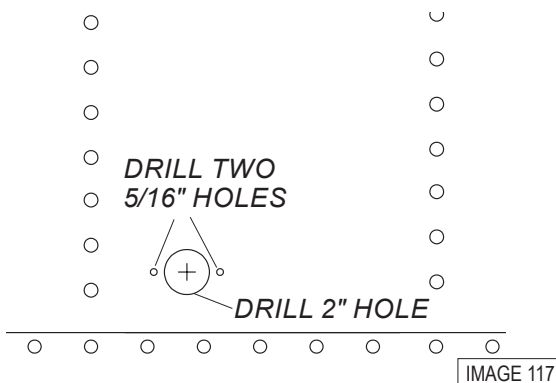

- STEP 3:** Fasten conductor socket (29) to trailer with two cap screws (8), flat washers (23) and nuts (9).

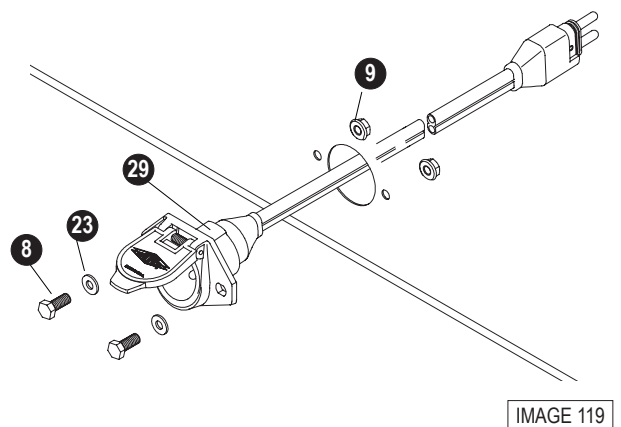

2309 SHURLOCK STREET | YANKTON, SD 57078-0713
PHONE: 1.866.748.7435 | FAX: 1.605.665.0501
SHURCO.com
