

Item	Part #	Description
1.	1122064	Solenoid Cover Assembly - ProTrap® SMART2™
2.	1704312	Motor-Reversing Solenoid - 3 Pt. Mt.

STEP 1: Disconnect power to ProTrap®. Remove existing gray cover and RF solenoid from ProTrap® intermediate bracket.

STEP 2: Install solenoid 2 onto ProTrap® intermediate bracket. Fasten with #10 x 1/2" cap screws.

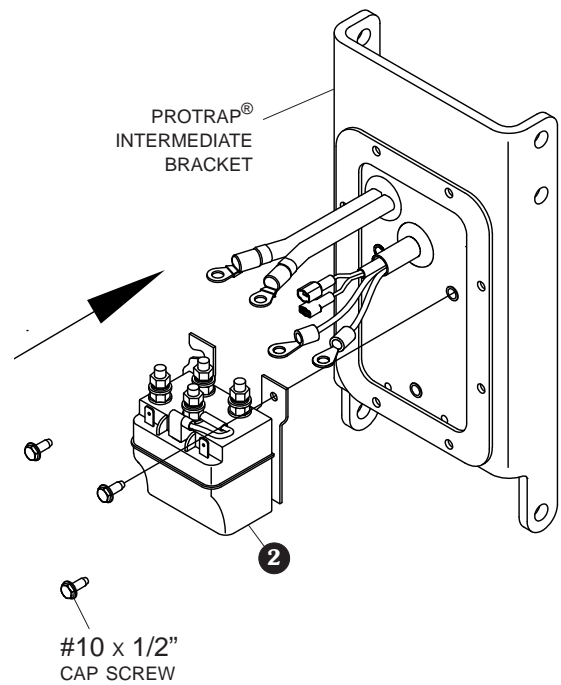
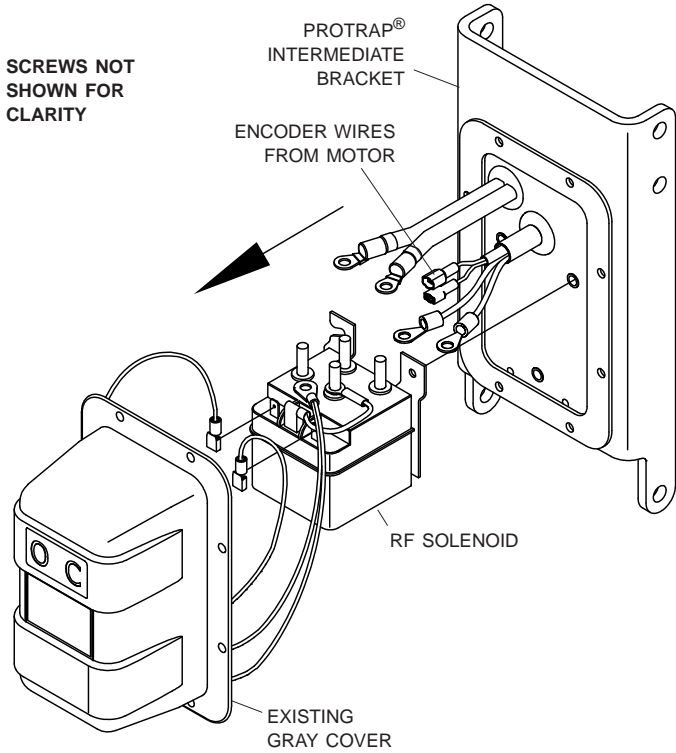

STEP 3: Connect wires from ProTrap® bracket to solenoid and from gray solenoid cover to solenoid as shown below.

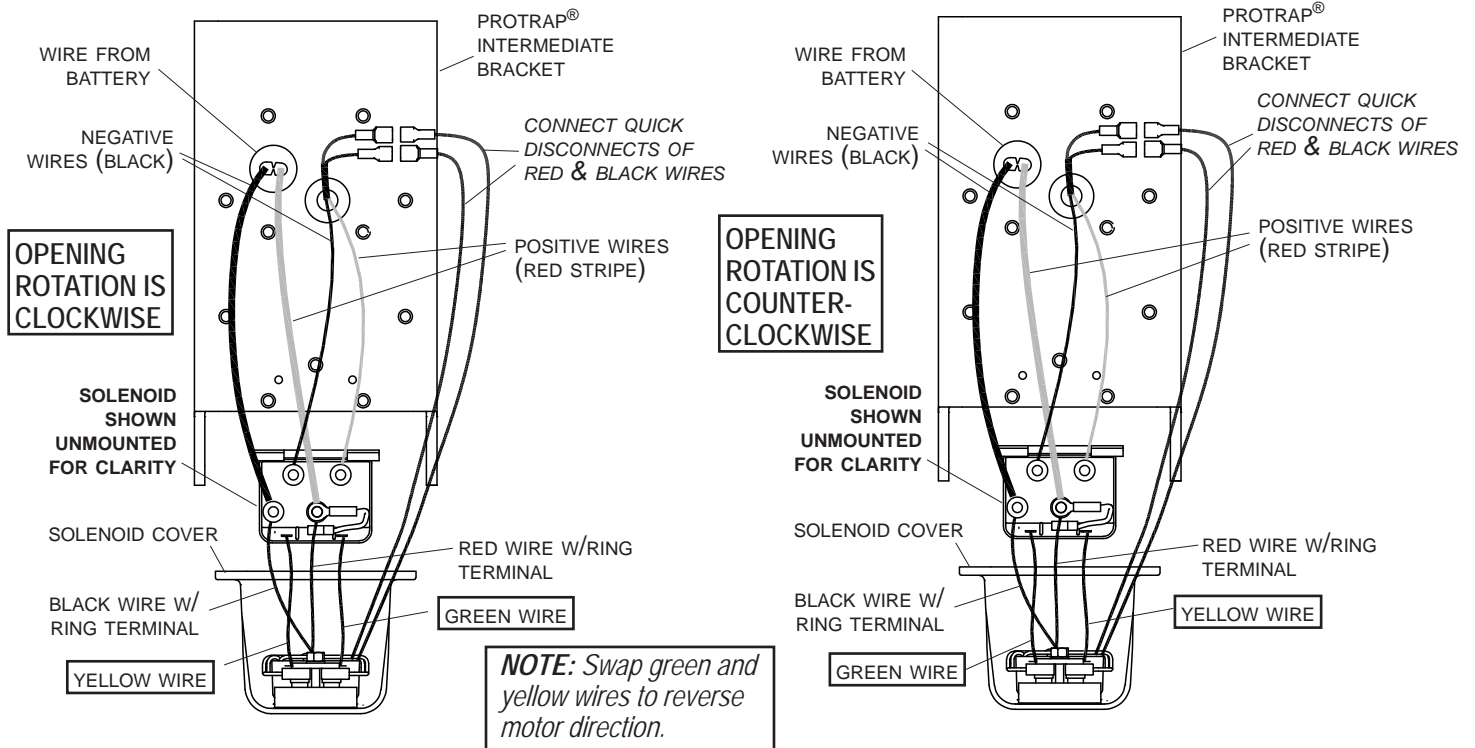

STEP 4: Reconnect power to ProTrap®. Pair (introduce) SMART2™ remote to ProTrap® as shown in remote instructions (P/N 1122198) and verify operation.

STEP 5: Replace solenoid cover and secure with #10 x 1/2" cap screws as shown at right.

