

Item	Part #	Description
1.	1123480	Solenoid Cover Assembly - 4500 HD Series SMART1+™
2.	1704312	Motor-Reversing Solenoid - 3 Pt. Mt.

STEP 1: Disconnect power to receiver. Remove existing gray cover and solenoid from receiver bracket.

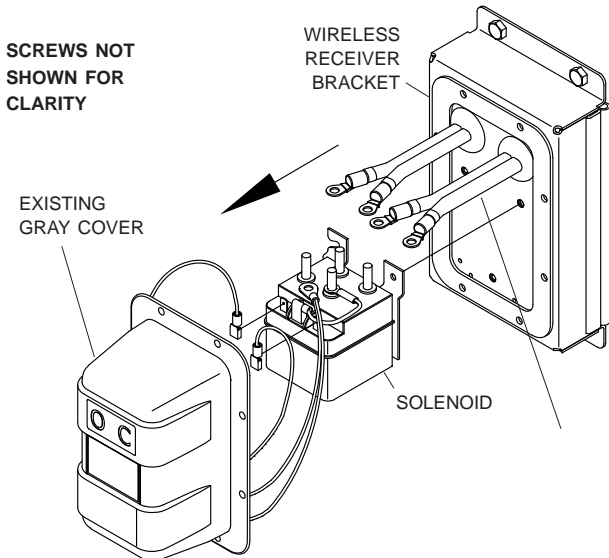

STEP 2: Install solenoid 2 onto wireless receiver bracket. Fasten with #10 x 1/2" cap screws.

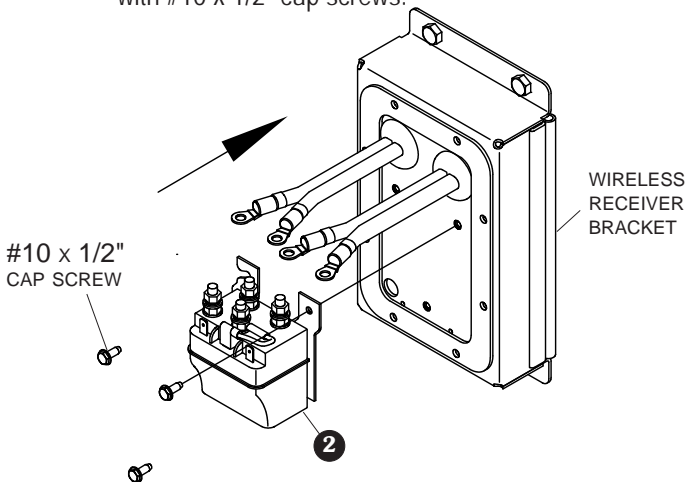

STEP 3: Connect wires from receiver bracket to solenoid and from gray solenoid cover to solenoid as shown below.

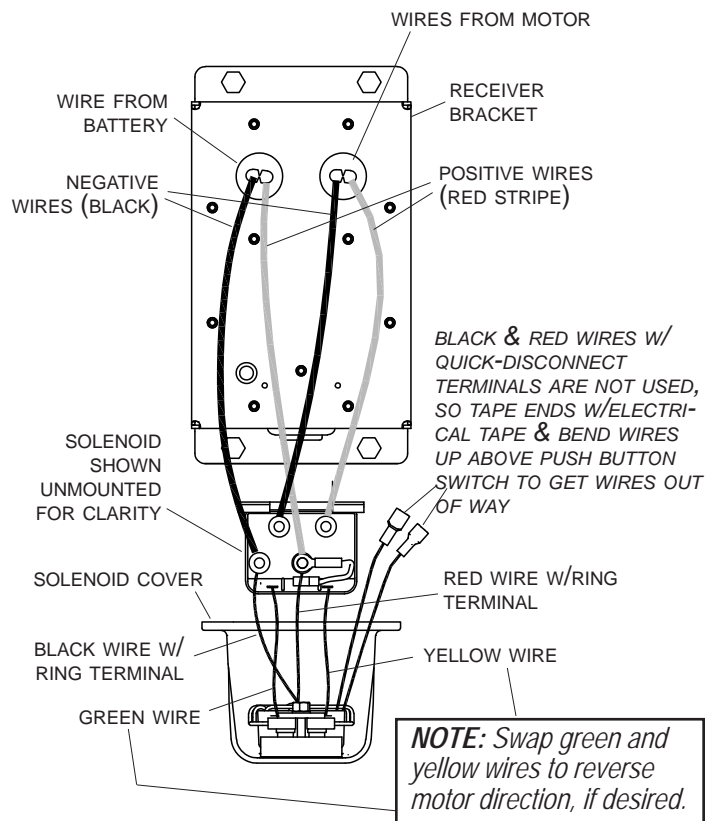

STEP 4: Reconnect power to receiver. Pair (introduce) SMART1+™ remote to receiver as shown in remote instructions (P/N 1123159) and verify operation.

STEP 5: Replace solenoid cover and secure with #10 x 1/2" cap screws.

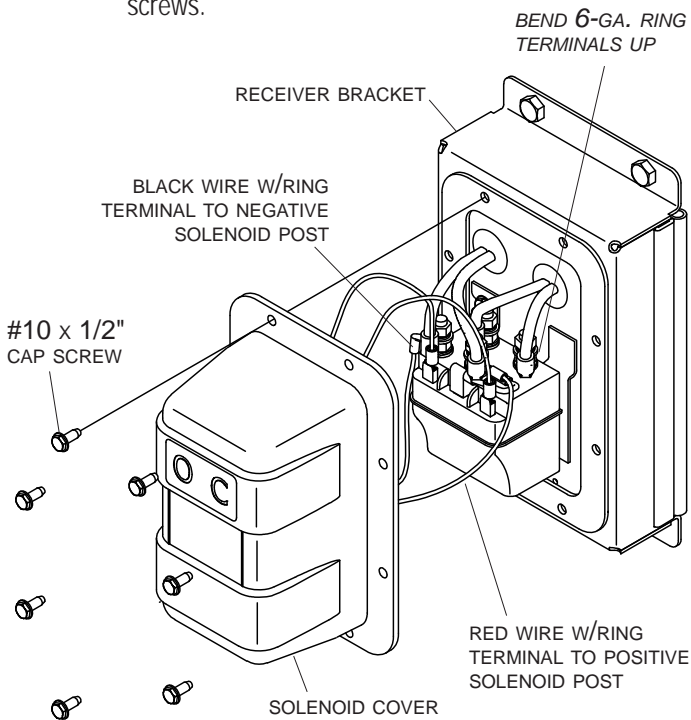

NOTE: Red and black wires with quick-disconnect terminals are taped and bent up inside grey cover above push button switch.

NOTE: If experiencing trouble getting grey cover to seat flush on gasket, check wire routings and adjust, if needed.

- Positive battery cable connected to front center post on solenoid may need to be rotated on stud to avoid interference with nut holding push-button assembly together.
- Two black switch wires crossing over black receiver above red LED should be horizontal and flush against black receiver in order to avoid interference with solenoid.