



WARRANTY

To ensure full warranty coverage, please follow the wiring specifications shown in the 4500 Series or 4500 Series HD Owner's Manual. Warranty is good for original owner only.

We warrant the 4500 Series motor (P/N 1120967) against manufacturing defects for a period of three (3) years. Warranty begins three (3) months from time of factory shipment. The 4500 Series motor can only be used in conjunction with the 4500 Series or 4500 Series HD system.

Use of the 4500 Series motor (P/N 1120967) in applications other than the 4500 Series or 4500 Series HD system voids the product warranty, unless the use is specifically approved in writing by Shur-Co®, LLC engineering management. The warranty period in these approved applications will be one (1) year, beginning from time of factory shipment. There are no warranties for used 4500 Series (P/N 1120967) motors or 4500 Series (P/N 1120967) motors that have been repaired, altered, modified or subjected to misuse, negligence or accident. We will not repair or place a product that fails or malfunctions due to ordinary wear and tear. The use of non-Shur-Co®, LLC parts in conjunction with the 4500 Series (P/N 1120967) motor will void this product warranty.

Returns of a 4500 Series (P/N 1120967) motor for warranty must be accompanied by a Return Merchandise Authorization number (RMA#), which can be obtained by calling Customer Service at 866-748-7435, and sent, with freight paid by us, to Shur-Co®, LLC, 2309 Shur-Lok Street, P.O. Box 713, Yankton, SD 57078 USA. All products returned without an RMA# will be refused. When we issue the RMA#, we will also issue a call tag to have UPS (or other freight company) pick up the product. C.O.D. warranty returns will not be accepted. We will pay no storage charges for a warranty product return prior to pickup by us or the freight company. If a warranty product return is scheduled to be picked up by us, we will pick up the product at our earliest convenience.

If the 4500 Series (P/N 1120967) motor returned is found, in our judgement, to have a manufacturing defect, our obligation under this warranty is limited to the repair or replacement of the product, which will be made by us. Repair or replacement will be at our discretion, with replacements being made using current models or parts performing in the equivalent function. Labor charges, other than those incurred at our factory, including, but not limited to, any labor to install a repaired or replaced product, are not covered under this warranty. All expenses associated with delivering defective products to our factory and delivering repaired or replacement products from our factory to the owner will be paid by us.

If the product returned is found, in our judgement, to be non-warrantable, the owner will be contacted to authorize repair work, the purchase of a replacement product or return of the product, all of which will be at the owner's expense. Payment authorization must be received by us before any non-warrantable product is repaired, replaced or returned. All expenses associated with delivering the repaired non-warrantable product, a replacement product or the non-warrantable product from the factory to the owner will be paid by the owner.

This limited warranty excludes all other warranties, express or implied, including, but not limited to, warranties of merchantability or fitness for a particular use. In no event will we be liable for any damages of any kind or nature to person, product or property, including, but not limited to, indirect, incidental, special, consequential or punitive damages of any kind, or damage for loss of profits or revenue, even if we have been advised of the possibility of such damages. In the event of a conflict between this product-specific warranty and any general warranty, this product-specific warranty will govern.



4500 SERIES MOTOR WARRANTY



IMPORTANT!

12-Volt Electrical Requirements

The Shur-Co® planetary gear motor must be used in conjunction with the following Genuine Shur-Co® parts:

- 40-Amp Circuit Breaker P/N 1704354
- Shur-Co® Electronic Controls

Use of unauthorized parts or improper installation may lead to premature component failure.

Shur-Co®, LLC

PO Box 713, 2309 Shur-Lok Street, Yankton, South Dakota 57078-0713
Phone: 1-866-748-7435 Fax: 1-605-665-0501 Website: www.shurco.com

4500 SERIES ELECTRIC ROLL TARP OPTION

SHUR-CO® WIRELESS PACKAGE - ORIGINAL SMARTRANSMITTER® WIRING

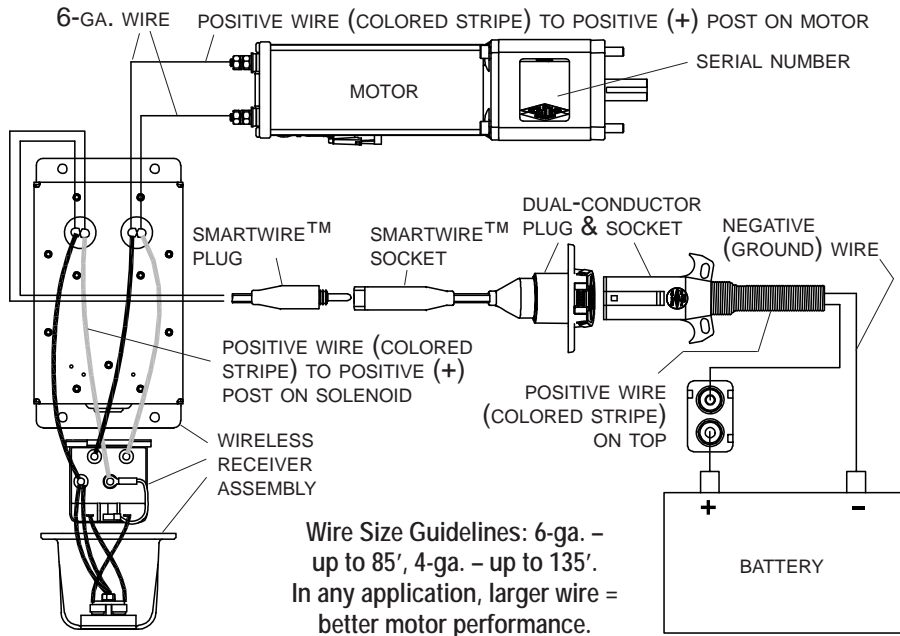

SHUR-CO® WIRELESS PACKAGE - SMART2™ WIRING

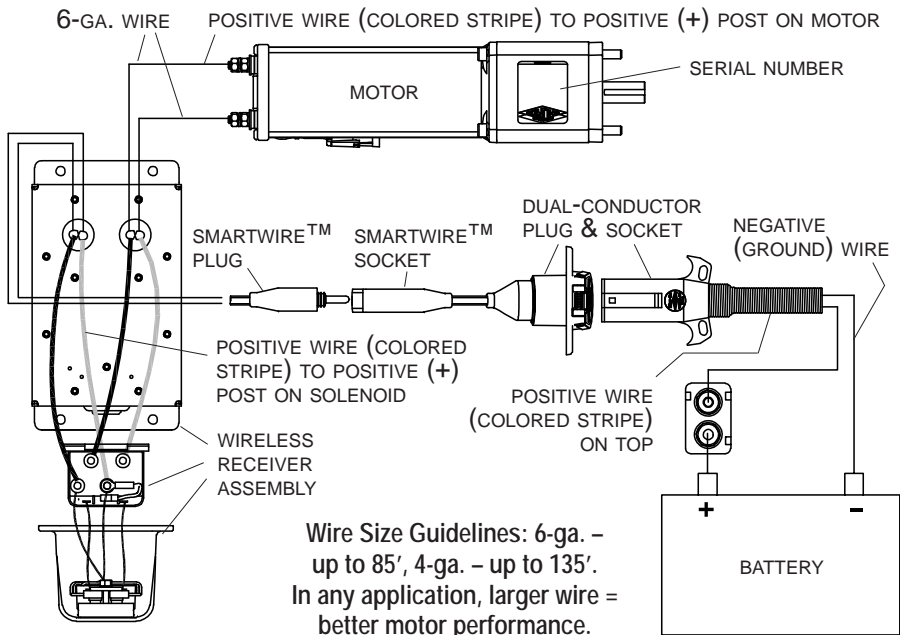

WIRING FOR IN-CAB ROCKER SWITCH

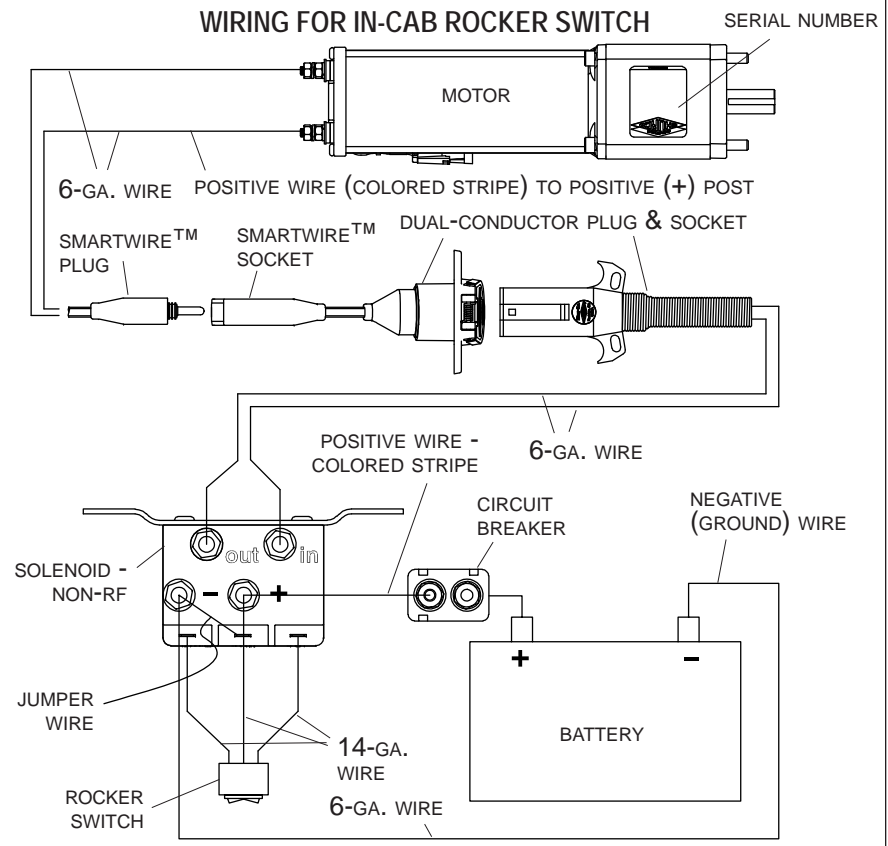

**Wire Size Guidelines: 6-Ga. - up to 85', 4-Ga. - up to 135'.
In any application, larger wire = better motor performance.**

MOTOR MOUNTING ASSEMBLY

- DO NOT USE POWER TOOLS
- DO NOT OVERTIGHTEN
- DO NOT USE THREAD LOCKER

TORQUE MOUNTING HARDWARE TO 70 IN.-LB. (5.8 FT.-LB.)

