

# BOX DETAIL SHEET FOR CABLE-LOK™ FOR BELLY DUMPS

ALL TARPS ARE CUSTOM-MADE TO ORDER AND ARE NON-RETURNABLE. CORRECT PHYSICAL MEASUREMENTS ARE ESSENTIAL FOR PROPER TARP FIT. PROVIDE ALL REQUESTED INFORMATION OR YOUR ORDER MAY BE DELAYED. DO NOT USE UNIVERSAL BOX SIZES. ALWAYS USE ACTUAL MEASUREMENTS. BOX SIZE AND FINISHED TARP SIZE ARE NOT THE SAME.

## CONTACT INFORMATION

G11BD-0618

NAME \_\_\_\_\_  
 ADDRESS \_\_\_\_\_  
 EMAIL \_\_\_\_\_  
 CITY \_\_\_\_\_ STATE \_\_\_\_\_ ZIP \_\_\_\_\_  
 PHONE \_\_\_\_\_ FAX \_\_\_\_\_  
 BOX/TRAILER MAKE \_\_\_\_\_

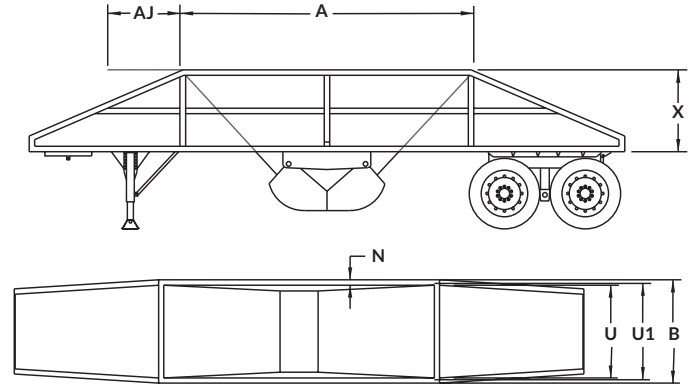

## BOX DIMENSIONS FOR BELLY DUMPS

A \_\_\_\_\_ UPPER BOX LENGTH  
 B \_\_\_\_\_ UPPER BOX WIDTH  
 Front \_\_\_\_\_ Center \_\_\_\_\_ Rear \_\_\_\_\_  
 N \_\_\_\_\_ TOP RAIL WIDTH  
 U \_\_\_\_\_ INSIDE BOX WIDTH  
 U1 \_\_\_\_\_ INSIDE PLANK-TO-PLANK WIDTH  
 X \_\_\_\_\_ BOX HEIGHT

TARP RAIL STYLE See Figure 1

SQUARE  SELF CLEANING  SQUARE W/PLANKS\*

\*Are planks flush with outside of top rail? Y / N (Circle one)

TARP COLOR(S) \_\_\_\_\_

## REPLACEMENT TARPS

TYPE OF TARP BEING REPLACED See Figure 2 for outer hole distance

CABLE-LOK™ W/CHANNEL  
 OTHER W/CHANNEL OTHER BRAND \_\_\_\_\_  
 OTHER W/RIVETS No. Rivets \_\_\_\_\_ Outer Hole Distance \_\_\_\_\_

\_\_\_\_\_ FINISHED SEWN TARP LENGTH

\_\_\_\_\_ FINISHED SEWN TARP WIDTH

TYPE OF CAP MEASURED See Figure 3

FACE MOUNT  TOP MOUNT

CR \_\_\_\_\_ END CAP RISE

CD \_\_\_\_\_ END CAP DEPTH Front \_\_\_\_\_ Rear \_\_\_\_\_

\_\_\_\_\_ OUTSIDE END CAP TO END CAP LENGTH

\_\_\_\_\_ BOX WIDTH

\_\_\_\_\_ BOX LENGTH

FIGURE 1

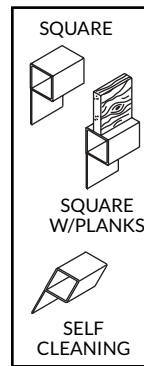

FIGURE 2

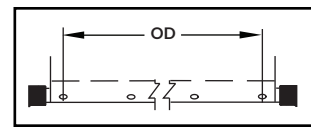

FIGURE 3

