

Item	Part #	Description
1.	1126700	Cable Return Roller - Double Tarp
2.	1704942	Arm Bearing Ring
3.	1700398	Self-Drilling Screw - 1/4" x 3/4"

STEP 1: Release wire lock pin and remove crank arm from roll tube for bottom tarp.

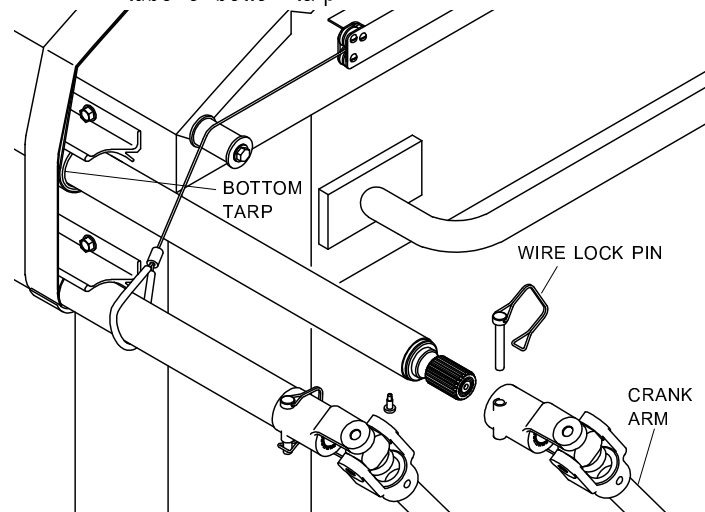

STEP 2: Assemble cable roller 1 and bearing rings 2 onto roll tube, leaving 1/8" space between roller and bearing rings.

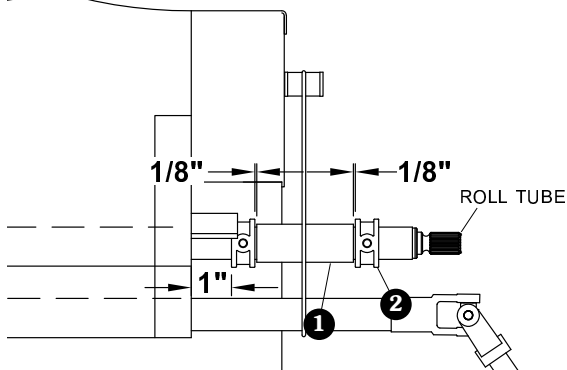

NOTE: Shorten cable roller 1 if needed to achieve correct distance for roll tube to extend past rear of box.

STEP 3: Fasten bearing rings 2 to roll tube with screws 3. Refasten U-joint and crank arm to roll tube with wire lock pin.

