



TARPING SYSTEMS & ACCESSORIES

P/N 1126694 Rev. A

INSTALLATION INSTRUCTIONS



Wiring Two ProTraps - Passenger Side

READ BEFORE INSTALLING

PO BOX 713 ■ 2309 SHUR-LOK STREET ■ YANKTON, SD 57078-0713
PHONE 1-800-4-SHUR-LOK (1-800-474-8756) ■ FAX 605-665-0501
www.shurco.com

SHOP ONLINE: www.shopshurco.com

Wiring Schematic - Two ProTraps

FRONT OF TRAILER

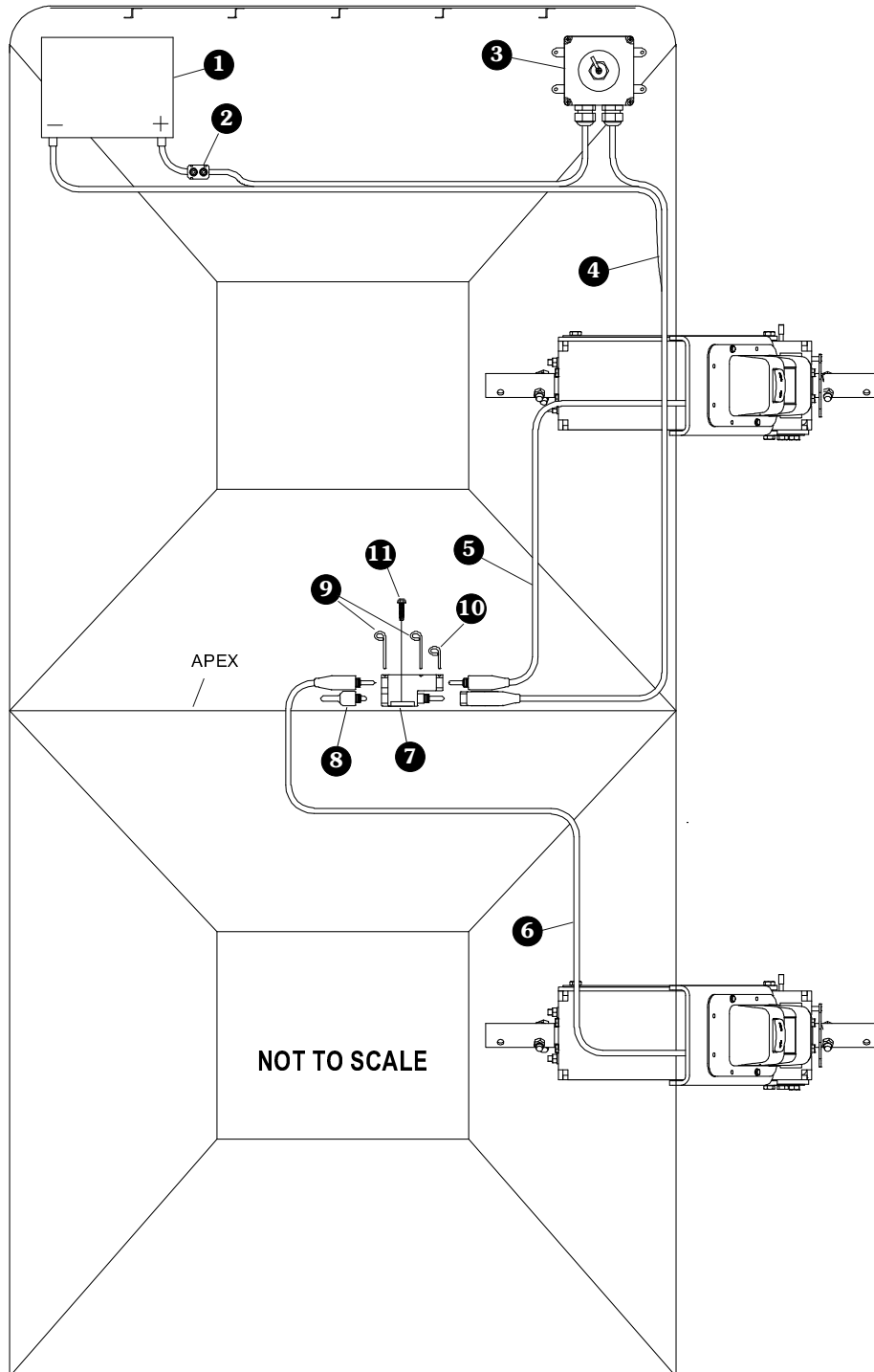

NOTE: Coat each connection with dielectric grease (P/N 1704378) to prevent corrosion.

CAUTION

Do not fasten SMARTwire™ components to trailer through hopper walls.

FRONT OF TRAILER

STEP 1: Route SMARTwire™ ④ along existing wiring on trailer.

STEP 2: Connect SMARTwire™ ④ to battery ①, circuit breaker ② and master disconnect switch ③. Route smart wire ④ to apex on trailer.

APEX OF TRAILER

STEP 3: To determine junction block location, route SMARTwires ④, ⑤ and ⑥ to location on apex where wires will reach. Position junction block ⑦ at this location. Using holes in junction block as guide, mark and drill two 7/32" holes.

STEP 4: Fasten junction block ⑦ to trailer with screws ⑪.

STEP 5: Insert plug ⑧ into junction block ⑦. Connect SMARTwires ④, ⑤ and ⑥ to junction block ⑦.

STEP 6: Secure SMARTwires ④, ⑤ and ⑥ to junction block ⑦ with lock pins ⑨ and ⑩.

STEP 7: Secure all wires to trailer with cable clips and 1/4" x 1" self-tapping screws. If needed, use cable ties.