

BOX DETAIL SHEET FOR DRIVEMAXX™ ELECTRIC SWING AUGER DRIVE

CORRECT PHYSICAL MEASUREMENTS ARE ESSENTIAL FOR PROPER TARP FIT. PROVIDE ALL REQUESTED INFORMATION OR YOUR ORDER MAY BE DELAYED. DO NOT USE UNIVERSAL BOX SIZES. ALWAYS USE ACTUAL MEASUREMENTS. NOTE: AT THIS TIME, PRODUCT WILL NOT WORK WITH CONVEYOR BELT AUGERS.

CONTACT INFORMATION

G013BD-1118

NAME _____
 ADDRESS _____
 EMAIL _____
 CITY _____ STATE _____ ZIP _____
 PHONE _____ FAX _____
 AUGER MAKE _____
 MODEL _____ YEAR _____



Shur-Co®
Dealer Locator



Drive Maxx™
Landing Page

Call your local dealer for more information or use the QR code at the far left for our Dealer Locator. Or use the QR code for Shur-Co's DriveMaxx™ for more product details on our website.

AUGER DIMENSIONS

A _____ TRANSITION BOX WIDTH (ACTUAL)

B TUBE DIAMETER

8" 10" 12" 13" 14"

FLANGE Yes No

If yes, enter distance from edge of of flange to pre-existing mounting hole.

C _____

KIT TYPE

SHURLINK™ SYSTEM (NO REMOTE)

SHURLINK™ SYSTEM (EZR™ INCLUDED)

EXTRA REMOTES

SHURLINK PRO™

SHURLINK EZR™

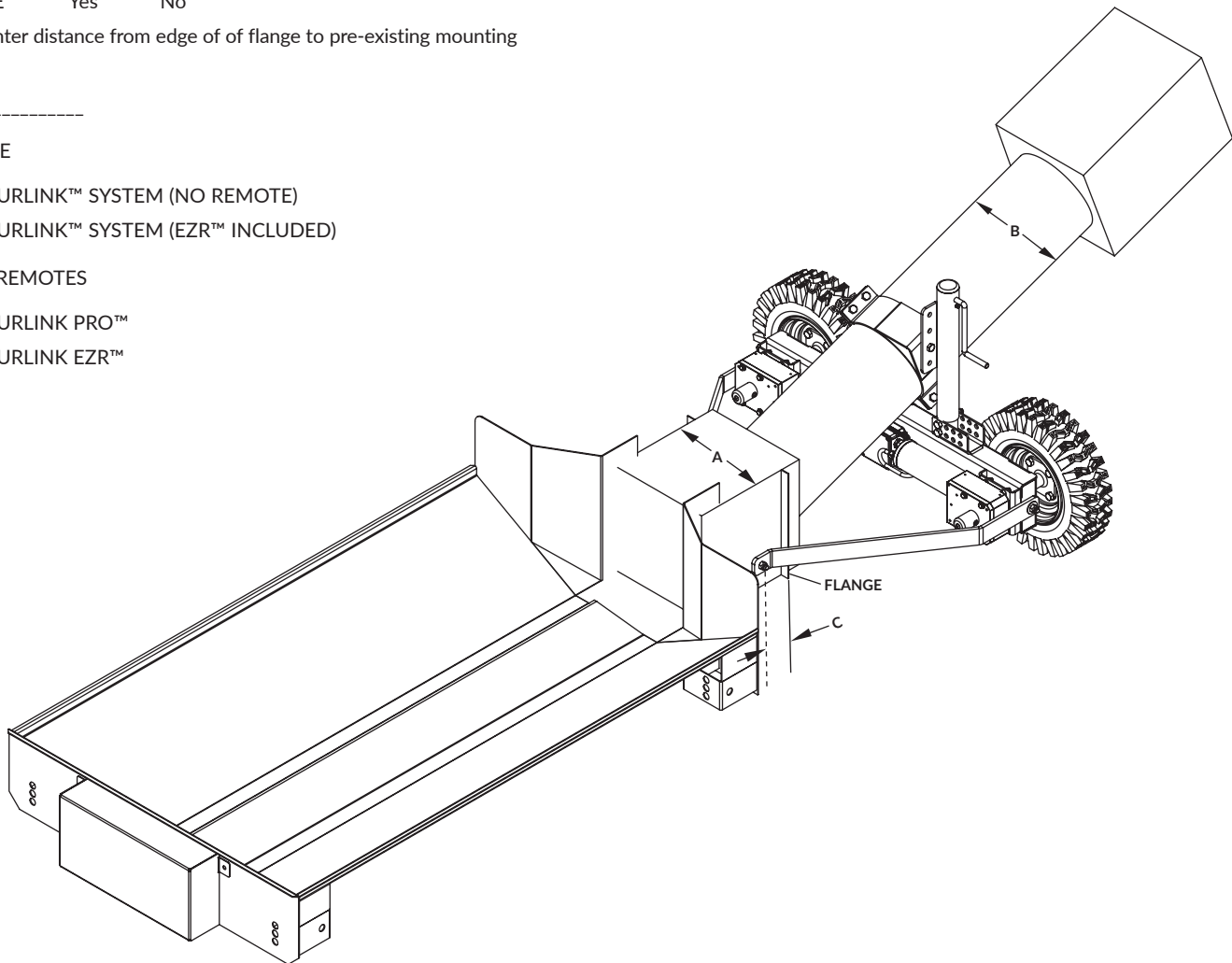

Fax 605.665.0501

Salesperson _____