

Item	Part #	Description
	1100824	Shur-Return™ Kit
	1107881	UPS-able
	1107880	Shur-Return™ Kit
		Tube Assembly
1.	1100138	Nylon End Plug
2.	1107879	Connector Sleeve
3.	1100826	Shur-Return™ Rope
4.	1100827	Spring Retainer Plug
5.	1100832	Tube Assembly (Spring - Rope - Slide)
6.	1700717	Eyebolt - 5/16"
7.	1704743	Self-Drilling Screw - #10 x 1/2"
8.	1700736	Self-Tapping Screw - 1/4" x 1/2"
9.	1701423	Hex Socket Set Screw - #10 x 3/16"
10.	1700411	Hex Nut - 5/16"
11.	1700419	Nylon Lock Nut - 5/16"

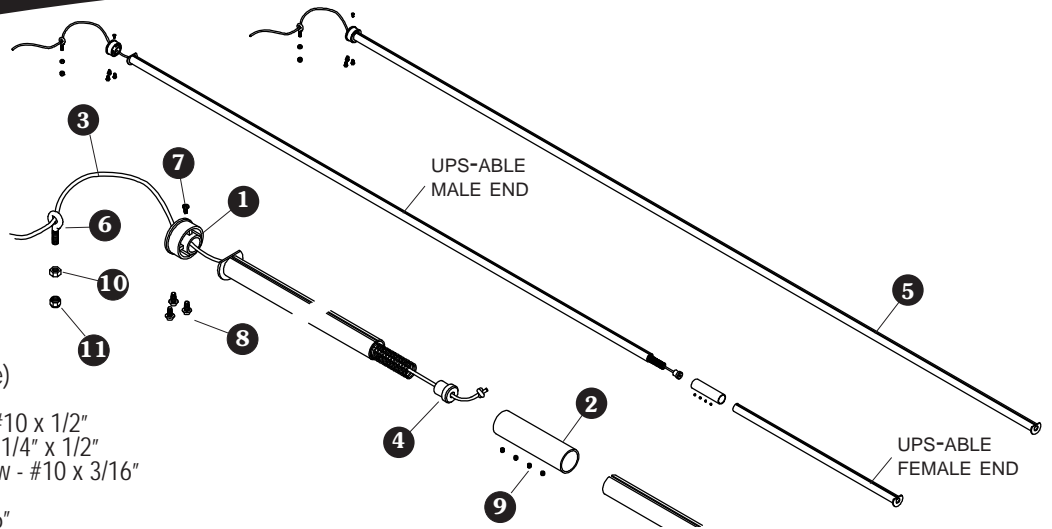

**NOTE:** Steps 1 and 2 are only for the UPS-able Shur-Return™.

**STEP 1:** Align grooves in male and female UPS-able Shur-Return™ ends and insert female end into connector sleeve. Tighten set screws.

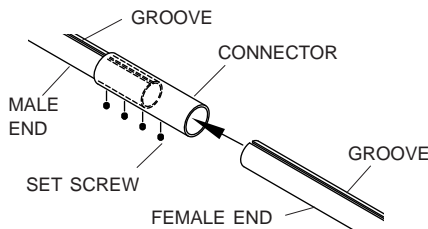

**NOTE:** Install set screws 180° from groove. Do not over tighten set screws.

**STEP 2:** Cautiously untie knot and slowly allow spring to expand to full length of UPS-able Shur-Return™.

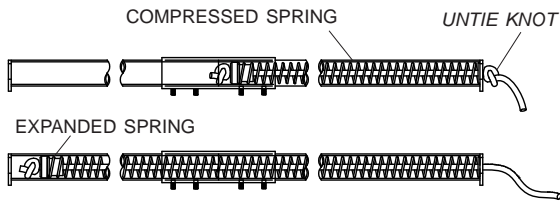

**NOTE:** Spring is compressed. Use caution when untying knot.

**STEP 3:** Remove all 1/4" x 3/4" screws from U-clamps on front 11' of tarp.

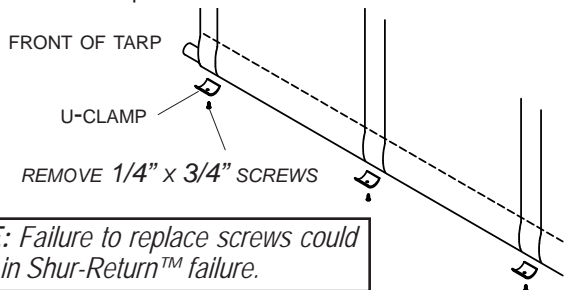

**NOTE:** Failure to replace screws could result in Shur-Return™ failure.

**STEP 4:** Insert Shur-Return™ into roll tube at front of trailer, with rope at open end of roll tube. Thread rope through nylon end plug. Reinstall U-clamps with 1/4" x 1/2" screws.

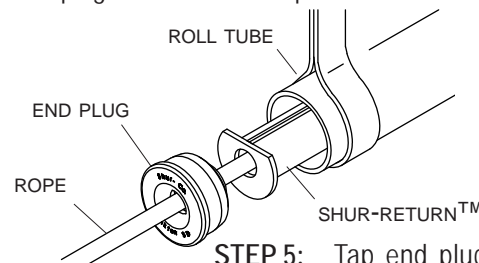

**STEP 5:** Tap end plug into roll tube and mark location 7/16" from edge of end plug. Secure end plug to roll tube with self-drilling screw.

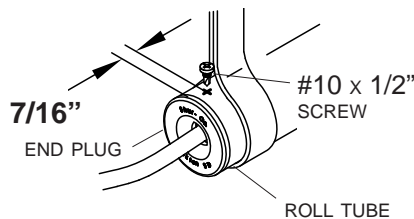

**STEP 6:** Drill 11/32" hole into latchplate 1 1/2" past end of tarp. Insert 5/16" eyebolt through hole and secure with hex nut and nylon lock nut.

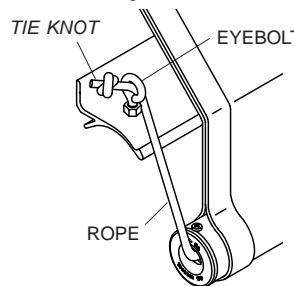
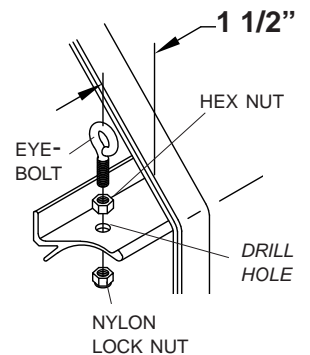

**STEP 7:** Insert Shur-Return™ rope through eyebolt, remove all slack from rope and tie knot. Cut off excess rope and melt frayed end.

Item	Part #	Description
	1114359	Front Stretch Cord Roll Return Kit
	1114361	X-Wide Front Stretch Cord Roll Return Kit
1	1111067	Roll Return Tube Set - 2 Pc.
	1115041	X-Wide Roll Return Tube Set - 2 Pc.
2	1114360	Roll Return Stretch Cord - 11 1/2'
	1114362	Roll Return Stretch Cord - 16 1/2'
3	1100138	Nylon End Plug
4	1703373	Flat Washer - 1/2"
5	1700717	Eyebolt Anchor - 5/16"
6	1700419	Nylon Lock Nut - 5/16"
7	1700411	Hex Nut - 5/16"
8	1704743	Self-Drilling Screw - #10 x 1/2"
9	1107680	Protective Stretch Cord Cover

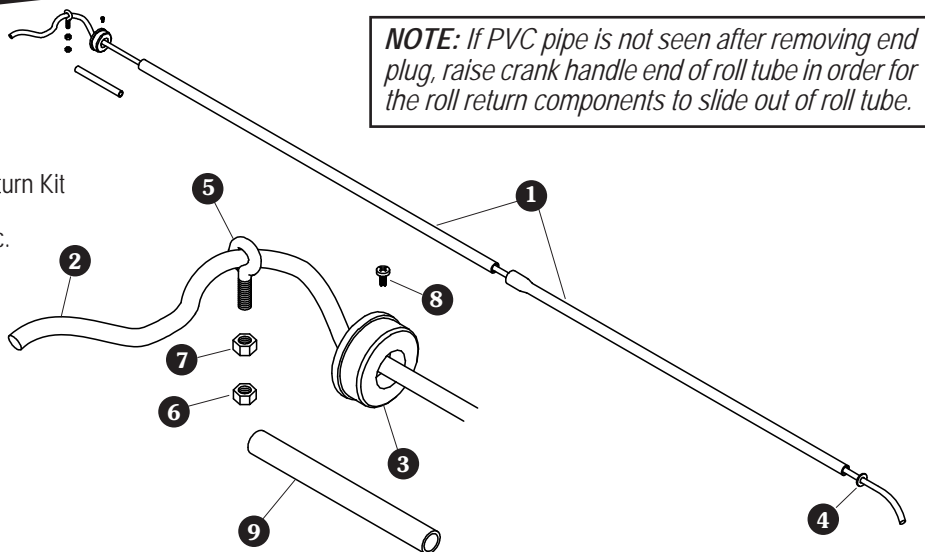

**STEP 1:** Press belled PVC pipe over end of straight PVC pipe. Press end plug into end of straight pipe.

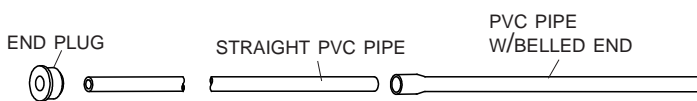

**STEP 2:** Insert stretch cord through pipes and end plug. Slide flat washer on end of stretch rope and tie knot.

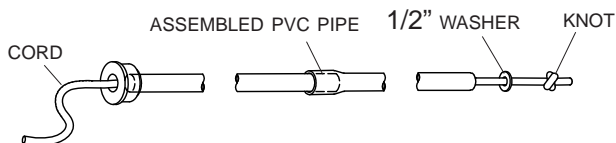

**STEP 3:** Insert roll return assembly into roll tube and lightly tap end plug into place.

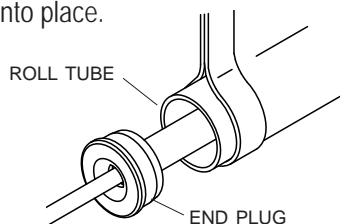

**STEP 4:** Mark location 7/16" from edge of roll return end plug. Secure end plug to roll tube with #10 self-drilling screw.

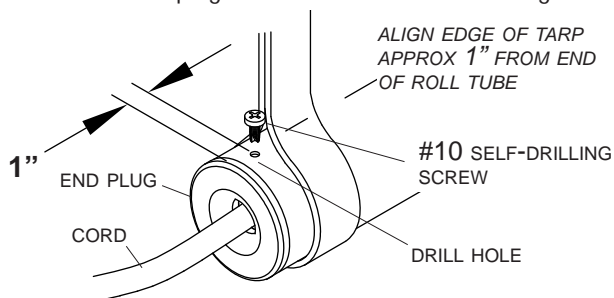

**STEP 5:** Drill 13/32" hole through latchplate 1 1/2" from end. Grind rough edges. Insert eye bolt through hole, secure with 5/16" nut and lock nut.

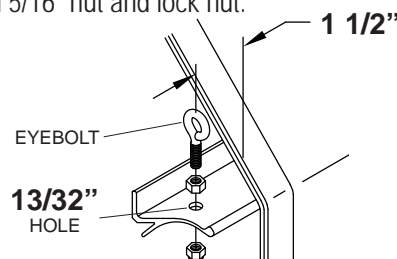

**STEP 6:** With tarp hanging over edge of box, pull stretch cord to remove slack in roll return assembly. Tie knot 6" to 12" from end of cord.

**STEP 7:** Slide protective cover over stretch cord.

**STEP 8:** Thread stretch cord through eye bolt. Tie knot on end of cord, creating enough tension to lift roll return slightly.

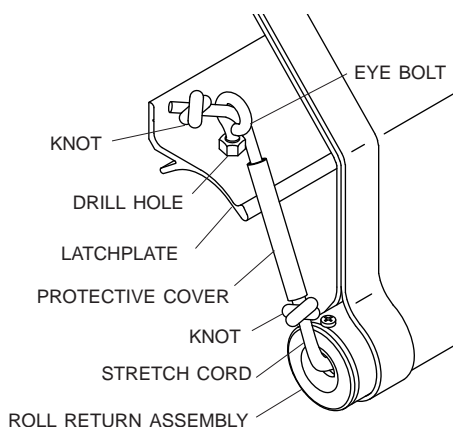

**STEP 9:** Test operation. Cut excess stretch cord and melt any frayed ends.