

Item	Part #	Description
	1119366	Junction Box Kit - 6 Hole
1.	1119364	Junction Box Back Plate
2.	1119365	Junction Box - 6 Hole
3.	1119438	Junction Box Mtg. Plate
4.	1702653	Machine Screw Nut w/Washer
5.	1704308	Flange Hd. Cap Screw - #10 x 1/2"
6.	1700381	Cap Screw - 1/4" x 1"
7.	1700398	Self-Drilling Screw - 1/4" x 3/4"
8.	1704556	Rubber Grommet
9.	1702707	Ring Terminal - 6 Ga. x 1/4" Stud
10.	1700436	Lock Washer - 1/4"
11.	1700408	Hex Nut - 1/4"

Routing wires through the sealed junction box greatly reduces corrosion on wire connections.

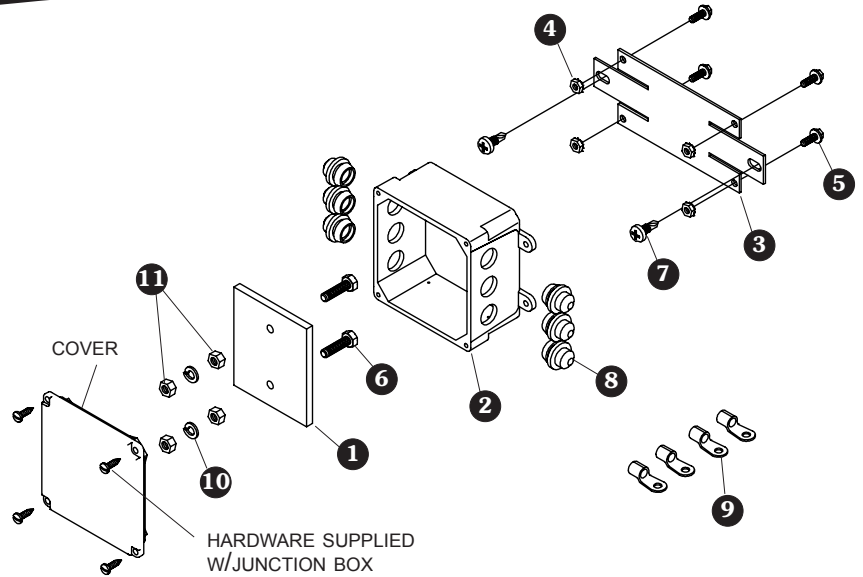

STEP 1: Insert 1/4" X 1" cap screw through holes in back plate and secure with nuts.

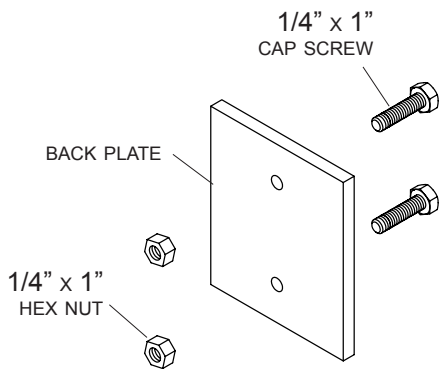

STEP 2: Place back plate loosely into junction box.

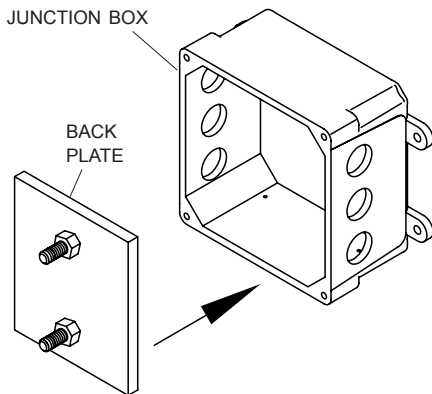

STEP 3: Fasten mounting plate to junction box with #10 X 1/2" cap screws and nut/washers.

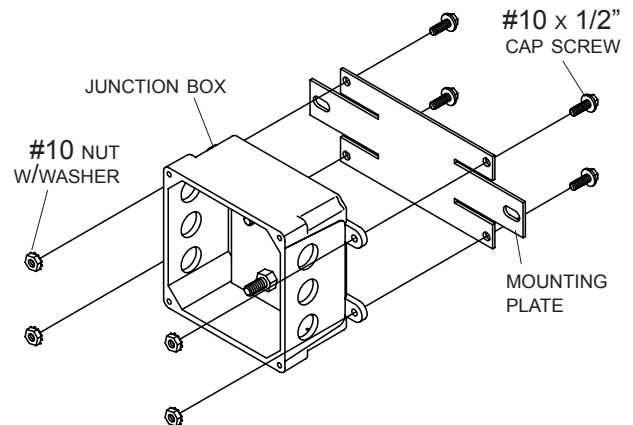

STEP 4: Install rubber grommets into holes in junction box.

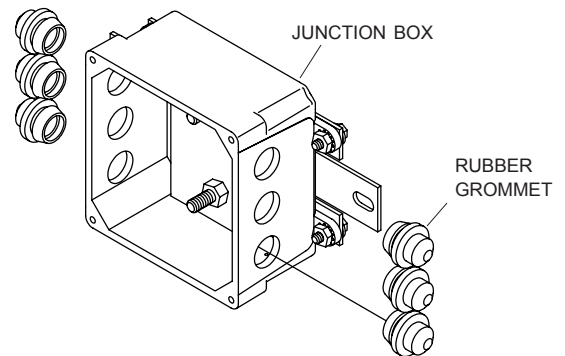

STEP 5: Locate junction box at front of trailer near wireless receiver. Align junction box so that weep holes are facing downward. Using slots in junction box as a guide, mark and drill 3/16" holes. Fasten junction box to trailer with 1/4" x 3/4" self-drilling screws.

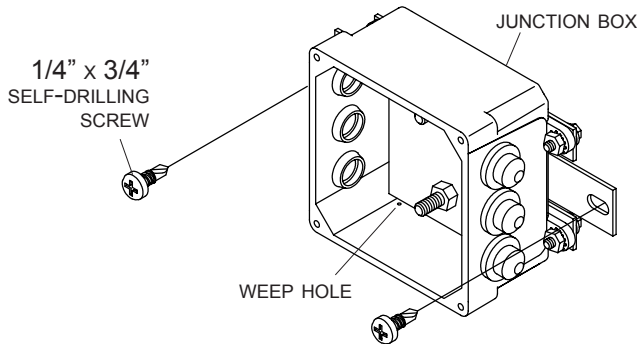

STEP 6: Pierce grommets with ball point pen so that terminal wires can be inserted through pierced holes.

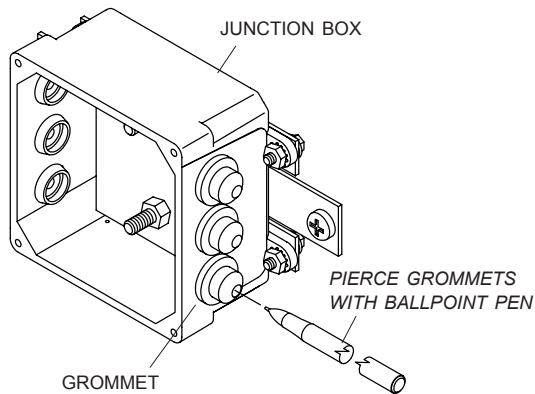

STEP 7: Run 6 ga. wire from conductor socket to junction box. Crimp 1/4" ring terminals to wire ends. Remove hex nut and lock washer from junction post assembly. Place positive wires on positive post and negative wires on negative post. Secure with hex nuts and lock washers.

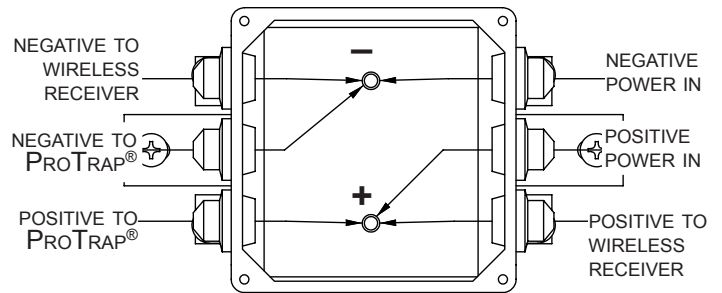
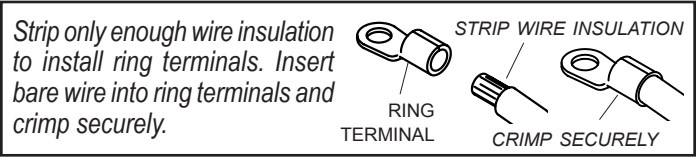

STEP 8: Fasten cover to junction box with supplied screws.

