



ENGINEERED TARPING SOLUTIONS

P/N 1117650 Rev. E

# OWNER'S MANUAL



## Electric Turning Point Bow Installation

*READ BEFORE INSTALLING*

PO BOX 713 ■ 2309 SHUR-LOK STREET ■ YANKTON, SD 57078-0713  
PHONE 1-800-4-SHUR-LOK (1-800-474-8756) ■ FAX 605-665-0501  
[www.shurco.com](http://www.shurco.com)

SHOP ONLINE: [www.shopshurco.com](http://www.shopshurco.com)

Shur-Co® warrants that all new, unused products are free from defects in materials and workmanship. This warranty is effective if the product is properly installed and used for the purpose intended and applies to the original buyer only. Shur-Co's obligation under this warranty is limited to repairing or, at its option, replacing any part that is returned, transportation prepaid, to Shur-Co®, Yankton, SD. If the product is, in our judgement, in fact defective. All materials returned without written authorization will be refused. Shur-Co® shall not be responsible to supply or pay labor to replace any part found defective, nor shall it be liable for any damages of any kind or nature to person, product or property.

There are no warranties for used products or products that have been repaired, altered, modified, subjected to misuse, negligence, accident or ordinary wear and tear.

**Shur-Co® products are sold without any express warranty except as set forth above.**

No person is authorized to modify the foregoing warranty in any respect whatsoever.

Shur-Co® is not obligated to honor warranty claims if approved O.E.M. or Genuine Shur-Co® parts are not utilized.

**SHUR-CO® OF SOUTH DAKOTA**

*Corp. HQ and Outlet Store*  
 2309 Shur-Lok St., PO Box 713  
 Yankton, SD 57078-0713  
 Phone: 1-800-4-SHUR-LOK  
 (1-800-474-8756)  
 Fax: 1-605-665-0501

**SERVICE CENTERS**

Shur-Co® of North Dakota  
 920 38th St. NW, Exit 66  
 Fargo, ND 58102  
 Phone: 1-701-277-5714  
 Fax: 1-701-877-1283

Shur-Co® of Ohio  
 1100 N. Freedom, PO Box 827  
 Ravenna, OH 44266  
 Phone: 1-330-297-0888  
 Fax: 1-330-297-5599

Shur-Co® of Texas/Houston  
 34505 I-10 West, S. Frontage Rd.  
 Brookshire, TX 77423  
 Phone: 1-281-934-1007  
 Fax: 1-281-934-3311

Shur-Co® of Oklahoma  
 1604 E. US Hwy 66  
 El Reno, OK 73036  
 Phone: 1-405-262-7600  
 Fax: 1-405-262-3842

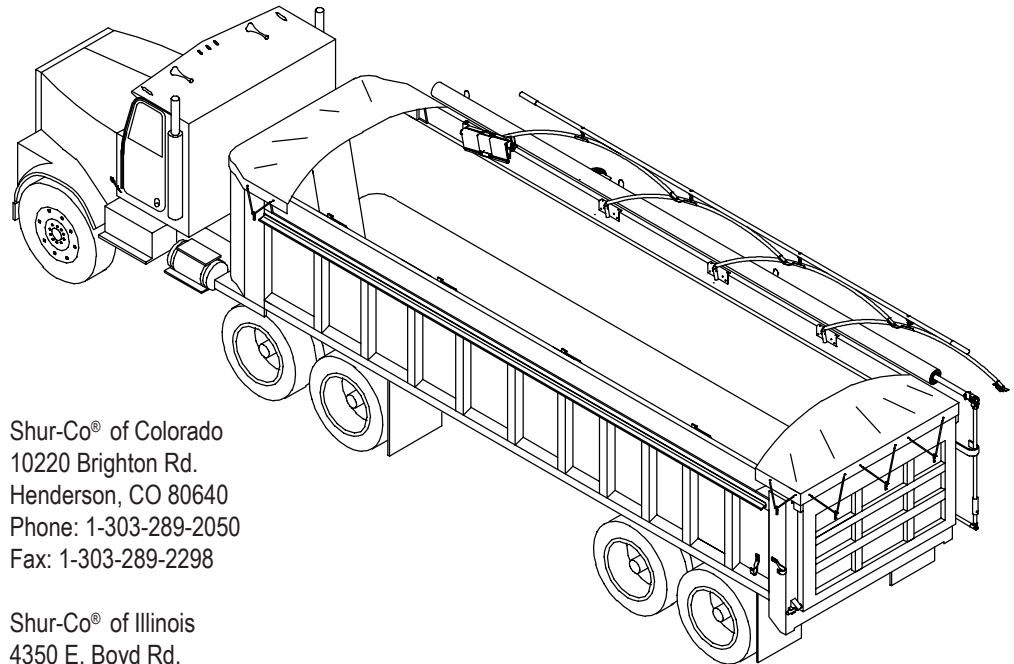

**ELECTRIC TURNING  
 POINT™ BOW SYSTEM**

Shur-Co® of Colorado  
 10220 Brighton Rd.  
 Henderson, CO 80640  
 Phone: 1-303-289-2050  
 Fax: 1-303-289-2298

Shur-Co® of Illinois  
 4350 E. Boyd Rd.  
 Decatur, IL 62521  
 Phone: 1-217-877-8277  
 Fax: 1-217-877-8270

Shur-Co® of Iowa  
 3839 Midway Blvd.  
 Ft. Dodge, IA 50501  
 Phone: 1-515-576-0959  
 Fax: 1-515-576-5578

**MESSAGE TO OWNERS**

Thank you for buying this tarping system from Shur-Co®. We appreciate your confidence in our products. Please read and thoroughly understand this manual before installing and/or operating this system.

Pay particular attention to important safety and operating instructions, as well as warnings and cautions. The hazard symbol  is used to alert users to potentially hazardous conditions and is followed by caution, warning or danger messages.

Failure to READ AND FOLLOW INSTRUCTIONS could result in failure of your tarping system and/or personal injury. Your trailer requirements may, however, call for minor variations to these instructions.

Please inspect your tarping system periodically. Repair or replace worn or damaged parts to your system.

QUESTIONS? CALL OUR HELP LINE:

**1-866-748-7435**

MON-FRI 8 AM-5 PM CENTRAL TIME

**SAFETY**

We at Shur-Co® are concerned with your safety and the safety of all those operating this system. Therefore, we have provided safety decals at various locations on your tarping system. Keep decals as clean as possible at all times. Replace any decal that has become worn or damaged, painted over or otherwise difficult to read. Replacement decals are available through Shur-Co® dealers.

**OPERATION**

1. Roll tarp open.
2. Check for overhead obstructions. Bows rise about 12" while opening.
3. Operate switch to swing bows to side of box.
4. After loading trailer, operate switch to allow bows to close over box.

**SAFETY INSTRUCTIONS**

- 1. Always wear safety glasses during installation.**
- 2. Keep body and clothing clear of moving parts.**
- 3. Do not operate under potentially dangerous obstacles.**
- 4. Return bows to secure position after operation.**
- 5. Use only OSHA-approved ladders or scaffolding during installation process.**
- 6. Close bows fully before raising trailer.**

**RUST PREVENTION**

To prevent rust, paint all exposed metal such as weld seams and/or metal exposed by grinding or cutting, with corrosion-resistant paint.

**TABLE OF CONTENTS**

- Hardware ..... 2
- Prepare Rope Pull System for Upgrade to Automatic ..... 3
- Pivot Bracket Installation ..... 4
- Automated Turning Point Bow Installation ..... 5
- Electric Actuator Installation ..... 6
- Actuator Shield Assembly ..... 7
- Limit Switch Assembly ..... 7-8
- Terminal Block Assembly ..... 9
- Rocker Switch - Cab Wiring ..... 10
- Rocker Switch - Trailer Mounting & Wiring ..... 11
- Wireless Receiver - Cab Wiring ..... 12
- Wireless Receiver - Trailer Mounting & Wiring ..... 13
- Wireless SMARTransmitter® Programming & Operating ..... 14
- Program Wireless SMARTransmitter® to Receiver ..... 15
- Replacement Parts ..... 16
- Troubleshooting Guide ..... 17-18

**TOOLS REQUIRED**

1. Steel Welder
2. Hammer
3. Center Punch or Transfer Punch
4. 3/8" Drill
5. Drill Bit - 17/64"
6. Drill Bit - 5/16"
7. Drill Bit - 3/8"
8. Wrench - 7/16"
9. Wrench - 1/2"
10. Wrench - 9/16"
11. Wrench - 3/4"
12. Wrench - 5/8"
13. Wrench - 18 mm
14. Ratchet
15. 1/2" Deep Socket
16. 9/16" Deep Socket
17. 7/16" Socket
18. Air or Electric Impact Driver
19. 9/16" Deep Impact Socket
20. Hacksaw (Metal Cutting Saw)
21. Flat Head Screwdriver
22. Phillips Head Screwdriver
23. Pliers
24. Wire Cutter
25. Utility Knife or Wire Stripper
26. Wire Terminal Crimper
27. Grinder
28. Tape Measure

**A**  1704191 - Pan Hd. Machine Screw - #6 x 7/8"

**B**  1701471 - Self-Drilling Screw - #12 x 1"

**C**  1703960 - Cap Screw - 1/4" x 1/2"

**E**  1702926 - Cap Screw - 5/16" x 7/8"

**F**  1701045 - Cap Screw - 5/16" x 3/4"

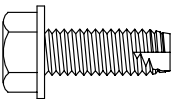
**G**  1700400 - Self-Tapping Screw - 3/8" x 1"

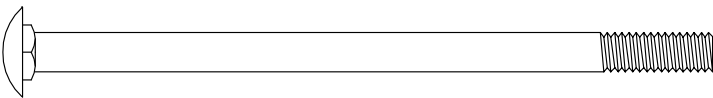
**H**  1701216 - Carriage Bolt - 5/16" x 5 1/2"

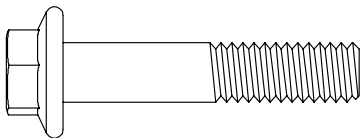
**J**  1704179 - Hex Flange Cap Screw - M12 x 60

**K**  1704184 - Nylon Lock Nut - #6

**M**  1704185 - Nylon Lock Nut - 1/4" Thin

**N**  1701543 - Nylon Lock Nut - 1/4"

**O**  1700411 - Hex Nut - 5/16"

**P**  1700419 - Nylon Lock Nut - 5/16"

**Q**  1700407 - Hex Nut - 3/8"

**R**  1704181 - Hex Nut - M12 x 1 3/4"

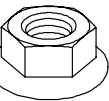
**S**  1704180 - Flange Lock Nut - M12 x 1 3/4"

**U**  1700427 - Flat Washer - 1/4"

**V**  1201237 - Flat Washer - 5/16"

**W**  1700434 - Lock Washer - 3/8"

**X**  1700437 - Lock Washer - 1/2"

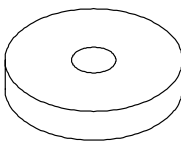
**Y**  1701215 - Washer - 1/4" x 1 1/4" x 5/16"

**Z**  1701118 - Spring Pin - 1/4" x 1 3/16"

**For existing Turning Point Bow™ System upgrades:** Remove the first existing Turning Point Bow™ and pivot bracket from the front of the box. These will be replaced with a new bow and pivot bracket assembly that is connected to an electric actuator.

If existing front bow stop is damaged, remove and replace with new bow stop provided. Remove rope return components and store in vehicle.

**STEP 1:** Remove existing hardware from ridgepole and front bow. Discard hardware.

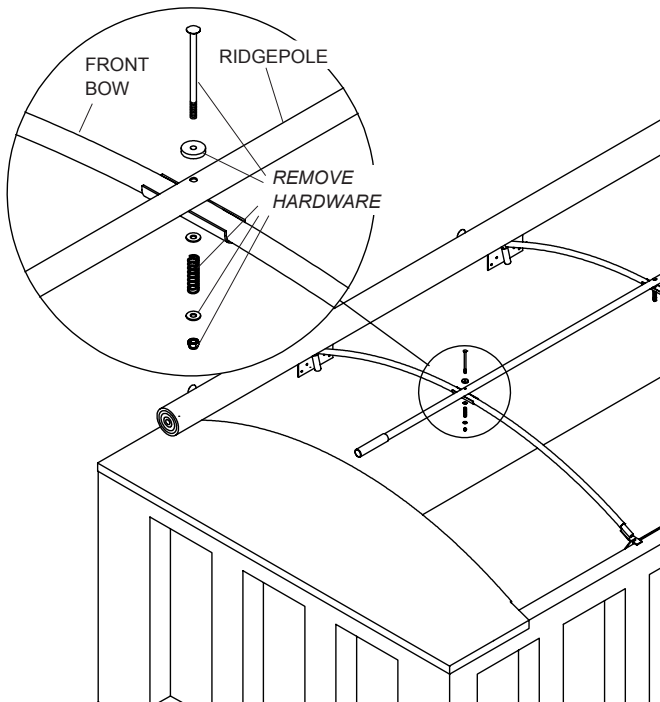

**STEP 2:** Remove and discard existing front bow by lifting bow up and out of bow pivot bracket.

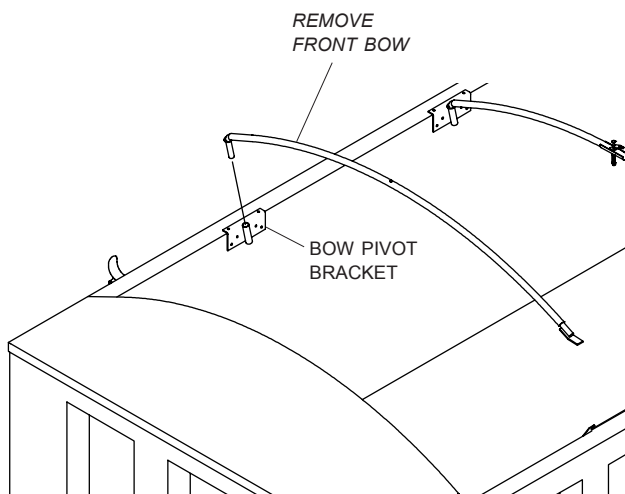

**STEP 3:** Remove and discard existing front bow pivot bracket from box.

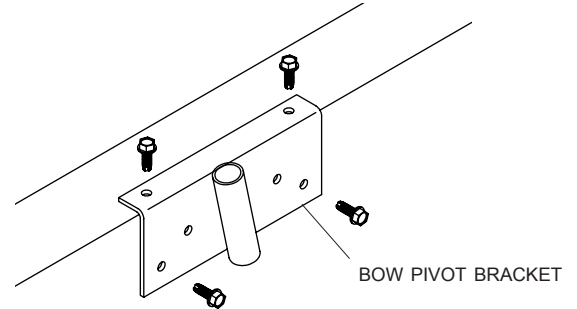

**STEP 4:** Inspect existing front bow stop. Replace with supplied bow stop if damaged.

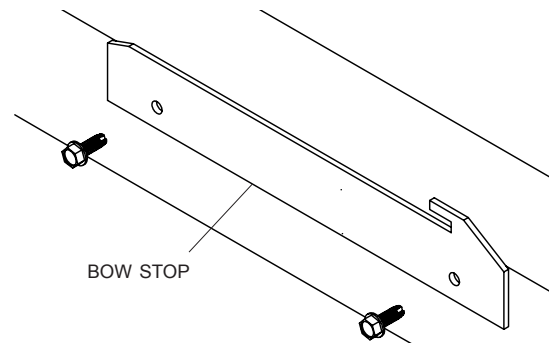

**STEP 5:** Remove rope return handle and spring-loaded locking pin from latching bow.

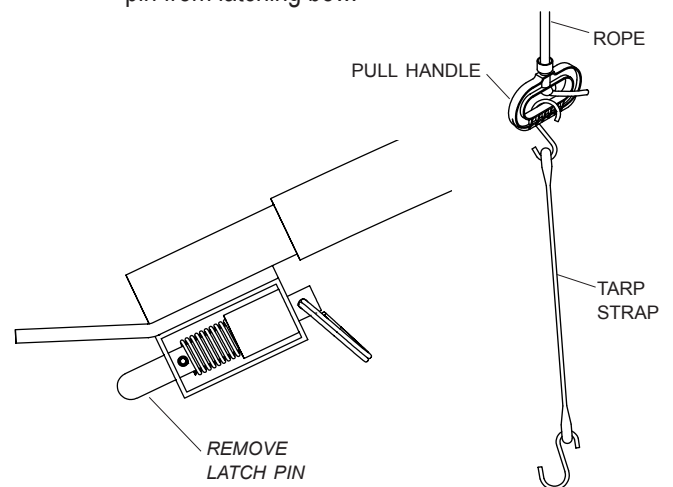

**NOTE:** Do not throw these parts away! Store rope return, handle and locking pin in vehicle for use in case of actuator or wiring failure.

**NOTE:** If you are installing a complete Turning Point™ Bow system, refer to the Turning Point™ Bow Owners Manual to determine the front bow pivot bracket location.

**STEP 6:** Mount electric bow pivot bracket in same location as the original front bow pivot bracket, fastening through existing holes in box.

a) **Steel/Aluminum Rails:** Mount bow pivot bracket with 3/8" x 1" self-tapping screws through top of bracket and through either upper or lower hole pattern on side of bracket.

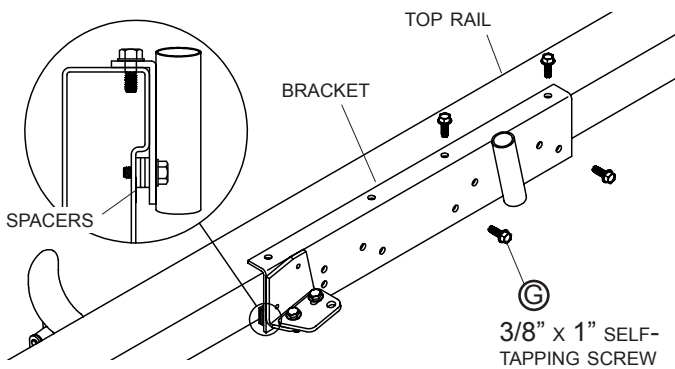

**TIP:** If installing spacers, align center of spacers with holes in bracket. Tape spacers in place while drilling holes.

b) **Rails with Planks:** Mount bow pivot brackets with 3/8" x 1" self-tapping screws through top of bracket and 3/8" x 2 1/2" carriage bolts, lock washers and nuts through upper or lower hole pattern on side of bracket. Secure 1/2" flat washers to outside of plank to minimize twist.

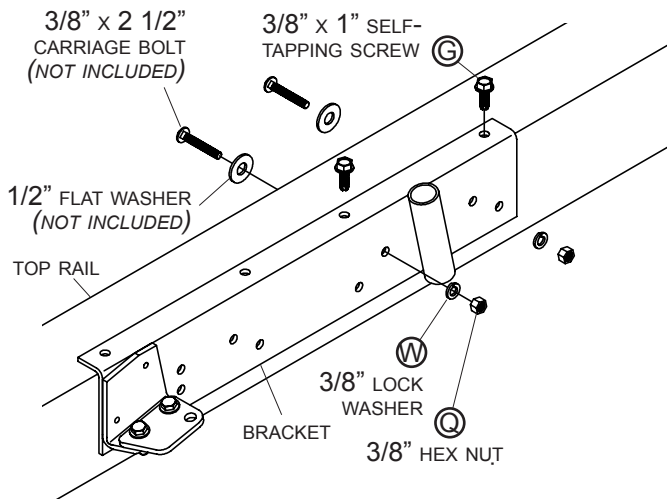

**STEP 7:** Drill into box or planks through holes in top of new bow pivot bracket and through upper or lower hole pattern on side of bracket.

**NOTE:** Drill 5/16" holes for 3/8" x 1" self-tapping screws and drill 3/8" holes for 3/8" x 2 1/2" carriage bolts.

**Steel/Aluminum Rails**

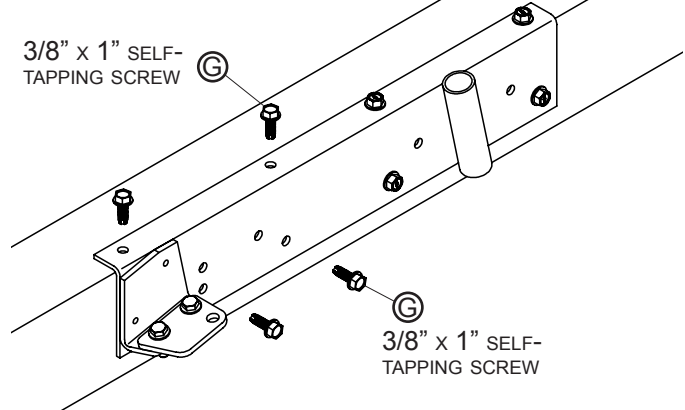

**Rails with Planks**

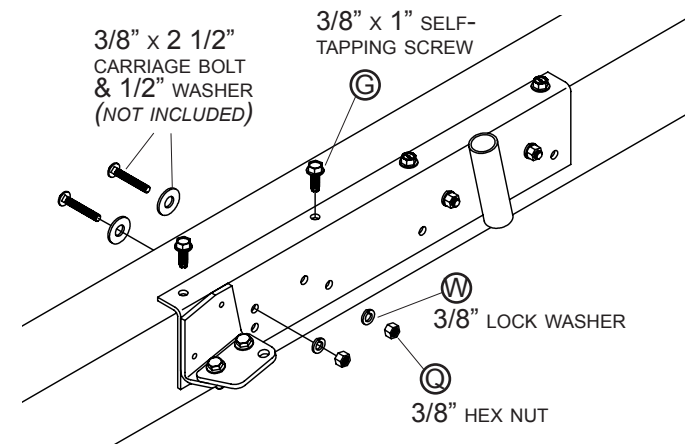

**STEP 8:** Fasten bracket through drilled holes as shown above.

**CAUTION**  
Mount pivot bow brackets to planks securely because they must withstand considerable stress.

**STEP 9:** Insert new bow into new bow pivot bracket. Secure with 1/4" x 1 3/16" spring pin, centering pin in bow shank.

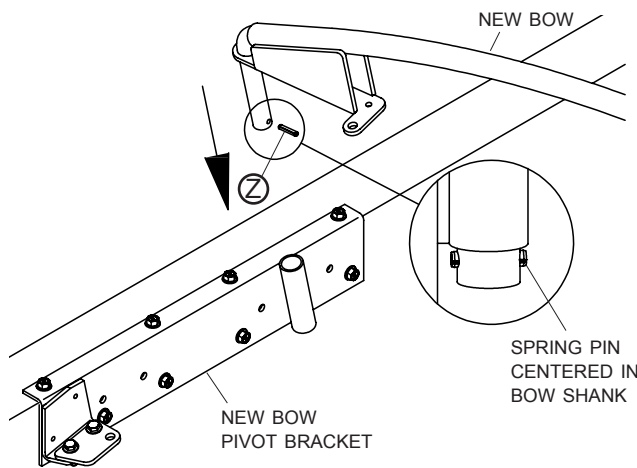

**NOTE:** Bow pivot brackets can be greased or lubricated. See Caution below before doing so.



**CAUTION**

**DO NOT lubricate if you intend to haul fertilizers or hazardous material. Explosive chemical reaction could occur.**

**TIP:** For easier installation on existing system upgrades, hold ridgepole and other bows open while installing new bow.

**STEP 10:** Determine bow length by aligning new bow rest provided in kit with bow and bow stop on top of side rail. Cut to length.

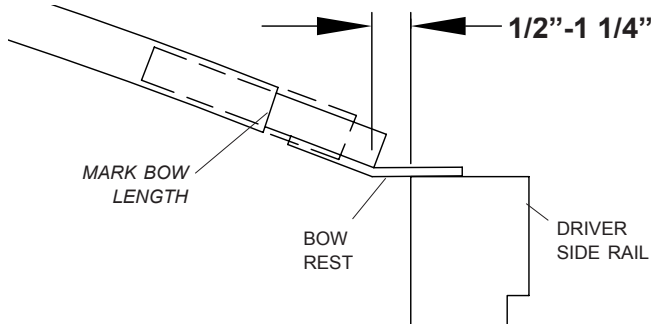

**STEP 11:** Adjust bow arch as needed so that bow rest slides into bow stop smoothly. Adjust bow to desired arch by pulling up or down on bow.

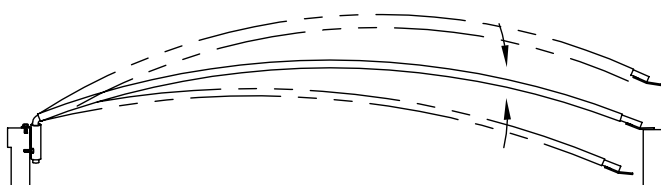

**STEP 12:** Weld bow rests to bows with 1/2" weld on each side of bow. De-burr sharp edges created by welding. Touch up with corrosion-resistant paint.

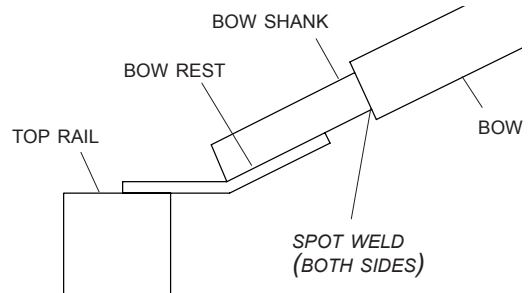

**STEP 13:** With all bows closed, fasten ridgepole to new front bow using existing hole in ridge pole. Fasten with 5/16" carriage bolt, 1 1/4" nylon washer, two 1/4" washers, spring and 5/16" lock nut as shown.

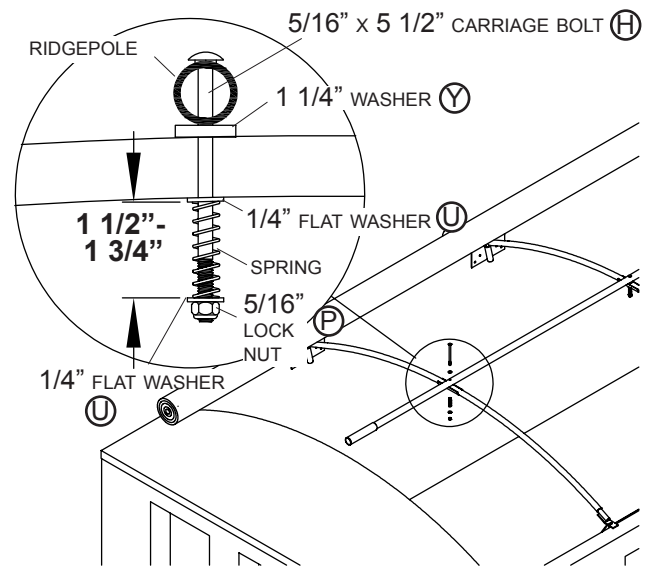

**STEP 14:** Test system by swinging bows open manually. Make sure bows are able to swing all the way open, then close system.

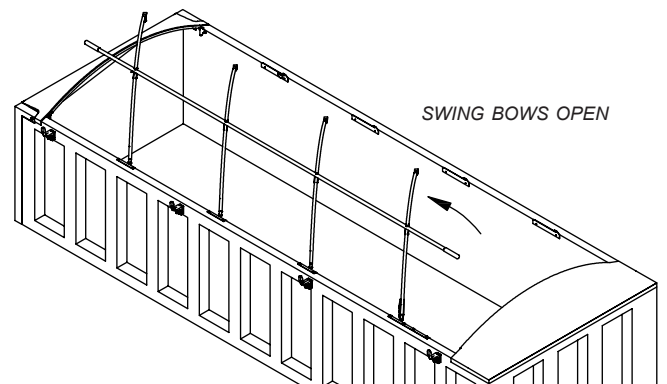

**NOTE:** Installing the actuator in the following manner will result in the bows opening to their full potential.

**STEP 15:** Using a 12V power source (12V vehicle battery, 12V battery charger), fully extend actuator by touching wire leads to terminal posts of power source. If actuator emits a loud clicking noise, the actuator is pulling closed and the wires are touching the wrong posts. With the wires touching the correct terminals, the actuator rod will extend until the overload clutch clicks again, at which point the actuator is fully extended.

**NOTE:** If using a battery charger to extend the actuator, make sure charger is set on 10 amps or less and is set for 12 volts. Do not use a charger that is set on a high-amp 'booster' or 'start' setting!

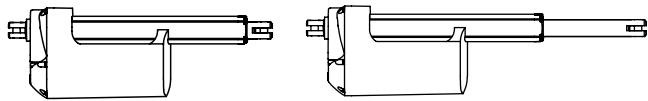

ACTUATOR FULLY RETRACTED

ACTUATOR FULLY EXTENDED

**STEP 16:** Push on new front bow to swing bow system open to fullest extent. Have an assistant hold bows open during next step.

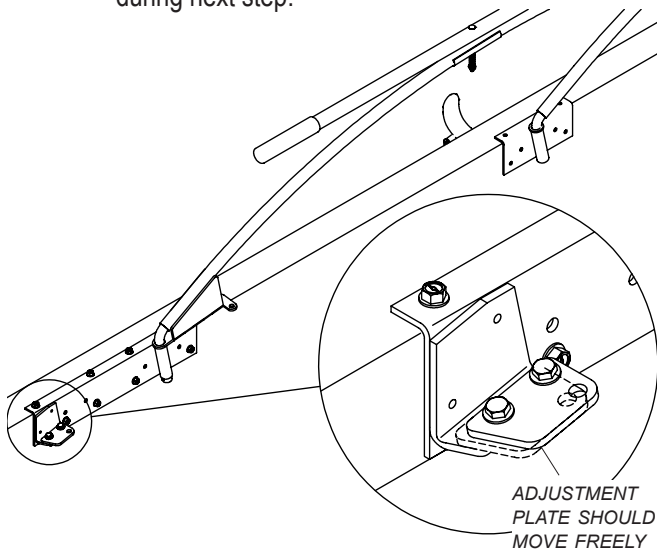

**NOTE:** In order for bows to open fully, hold bow system open by front bow while installing actuator.

The adjustment plate on the pivot bracket assembly should move back and forth freely at this point. If for some reason it has been fastened down securely and will not slide, loosen the nuts until the plate easily slides back and forth.

**STEP 17:** Secure actuator to fixture plate on bow and to adjustment plate on pivot bracket with metric flange bolts and flange nuts (bolt heads pointing down as shown). With actuator secured and bows held fully open, tighten fasteners to secure adjustment plate to pivot bracket.

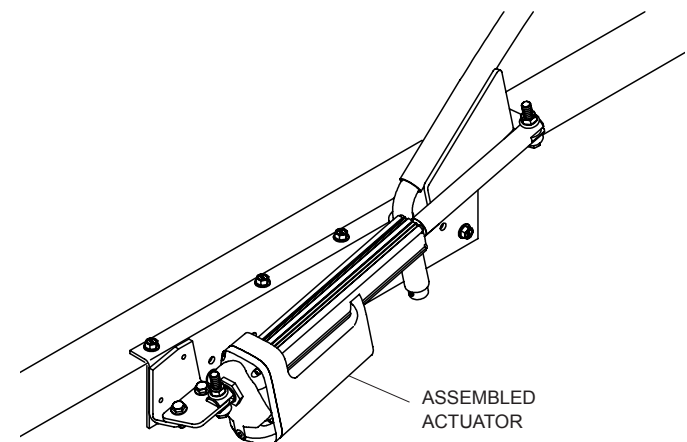
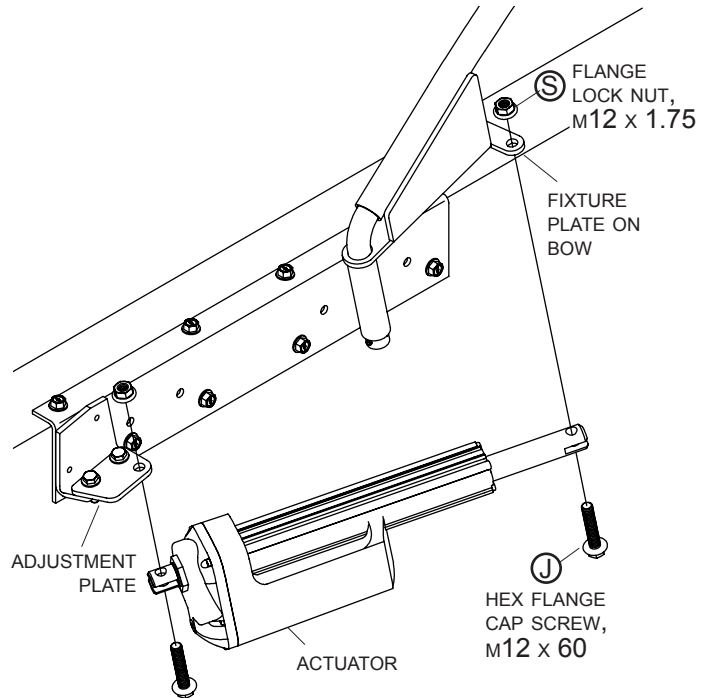

**STEP 18:** Test the system by again touching the wire leads from the motor to a 12V power source. The actuator's overload clutch will click when it reaches either end of its stroke. If the turning point system has been installed correctly, the bow rest should hit the bow stop either just before the actuator clicks or at the same time. If the bow is not returning completely to the bow stop, move the adjustment plate on the pivot bracket assembly back until it does. The result will be that the bows will not quite open to their full potential, but they will close completely.

**STEP 19:** Align holes in actuator shield with bolts fastening actuator to adjustment plate on pivot bracket and to fixture plate on bow. Slide shield onto bolts so that shield rests on flange nuts. Grip flange nuts with wrench while securing shield with lock washer and nuts.

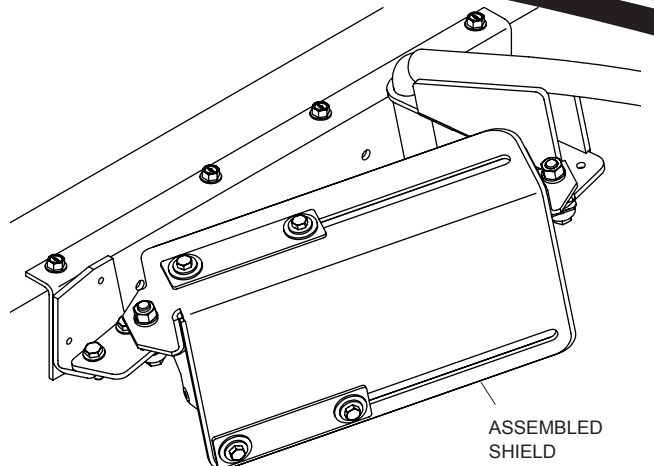
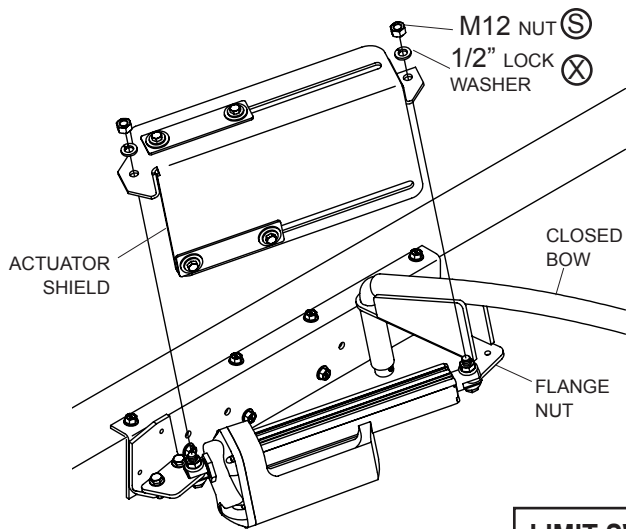

**NOTE:** Install limit switch assembly between first and second tarp stop at front of box. To install switch on outside of box, first remove fixed tube from easy-off tarp stops and set tube on top of box.

**LIMIT SWITCH ASSEMBLY**

**STEP 20:** Mount switch assembly to box in same manner as tarp stops. Set top edge of mounting bracket at same height from top rail as tarp stop bodies. It is preferable (but not necessary) to locate the assembly within 10" of the second tarp stop, leaving enough wire to reach the terminal block (refer to step 23 for terminal block location).

**STEP 21:** Use mounting bracket as a guide to mark and drill holes. Drill 5/16" holes when mounting to a steel or aluminum top rail; drill 3/8" holes when mounting to a wooden plank. Fasten mounting bracket to steel or aluminum rail with 3/8" x 1" self-tapping screws, adding lock washers and nuts if possible. Fasten mounting bracket to plank with 3/8" x 2 1/2" carriage bolts (not included), lock washers and nuts.

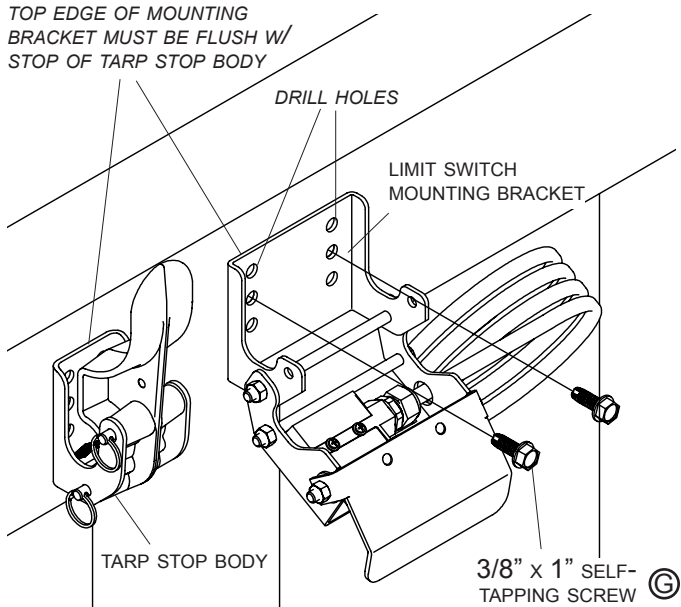
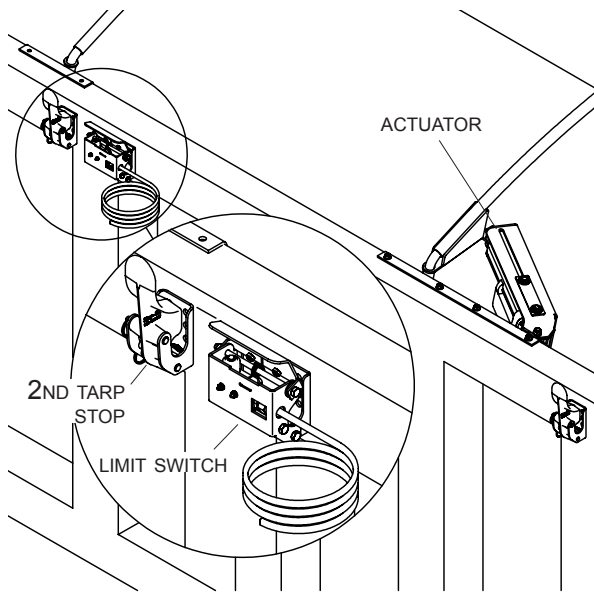

**NOTE:** When mounting assembly close to a tarp stop, be sure to leave room for removal of tarp stop or limit switch assembly fasteners.

**STEP 22:** Re-install fixed tube and tarp into limit switch mounting bracket and tarp stops. Lock tarp stops. Lock switch assembly into position by tightening bolts and nuts (tighten only until nuts begin to clamp bracket). Verify flipper bracket will close and spring open easily when released.

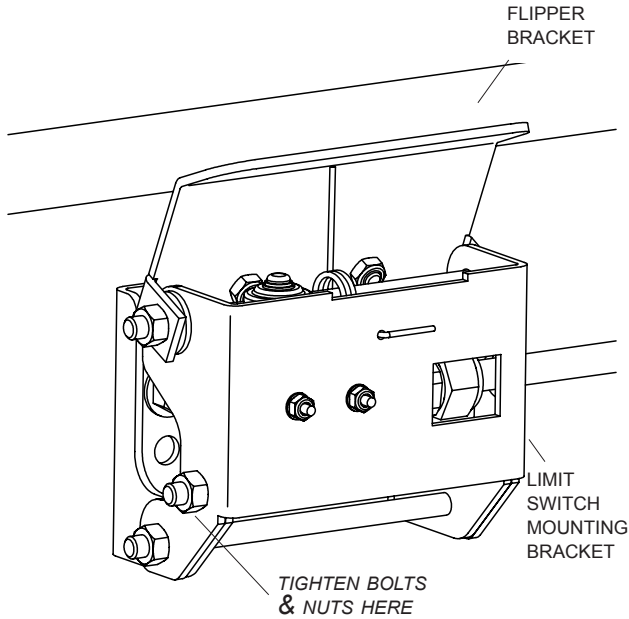

**STEP 22a: 3" Offset Tarp Stops:** Fasten adapter bracket to spring-loaded flipper bracket with 1/4" x 1/2" cap screws, and lock nuts. The adapter bracket allows the limit switch to operate with a 3" offset tarp stop.

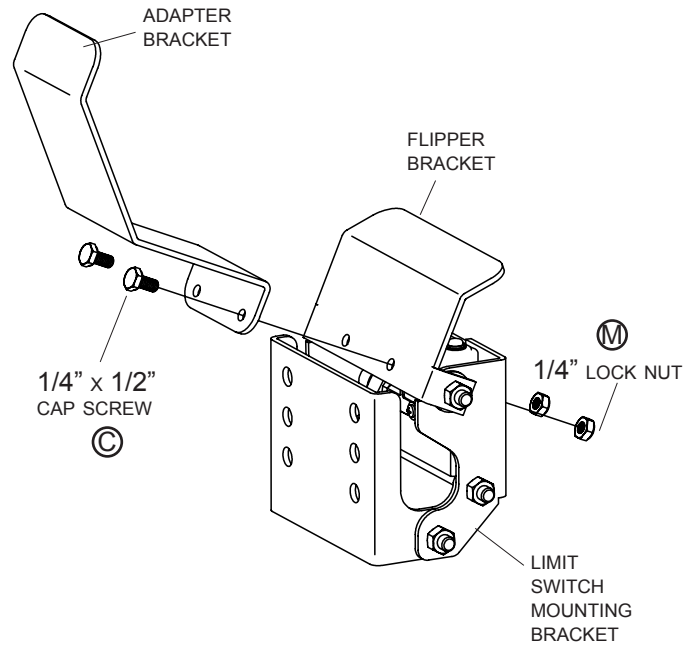

*Tarp actuates limit switch assembly when rolled completely open.*

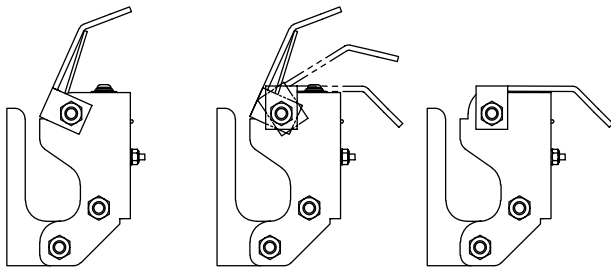

SWITCH FULLY OPEN  
(ACTUATOR NON-OPERABLE)

SWITCH FULLY CLOSED  
(TARP ROLLED OPEN COMPLETELY  
- ACTUATOR OPERABLE)

**NOTE:** For use with easy-off 6" offset tarp stops only.

*Tarp actuates limit switch assembly when rolled completely open.*

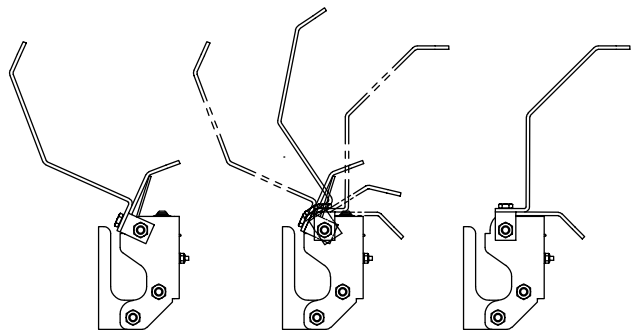

SWITCH FULLY OPEN  
(ACTUATOR NON-OPERABLE)

SWITCH FULLY CLOSED  
(TARP ROLLED OPEN COMPLETELY  
- ACTUATOR OPERABLE)

**NOTE:** For use with easy-off tarp stops only.

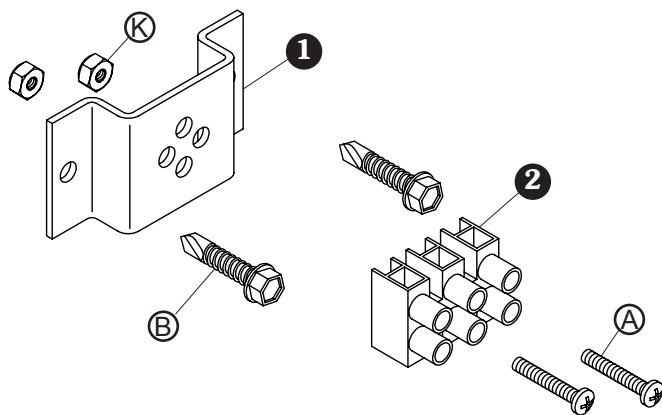

Item	Part #	Description
1.	1117647	Terminal Block Mounting Bracket
2.	1704190	Terminal Block
A.	1704191	Pan Hd. Machine Screw - #6 x 7/8"
B.	1701471	Self-Drilling Screw - #12 x 1"
K.	1704184	Lock Nut - #6

**NOTE:** The terminal block allows an easier connection for the three wire leads coming from the limit switch, actuator and solenoid (or wireless receiver).

**STEP 23:** Determine terminal block location. Locate in a safe place near actuator, where it can be easily reached with all three wire leads.

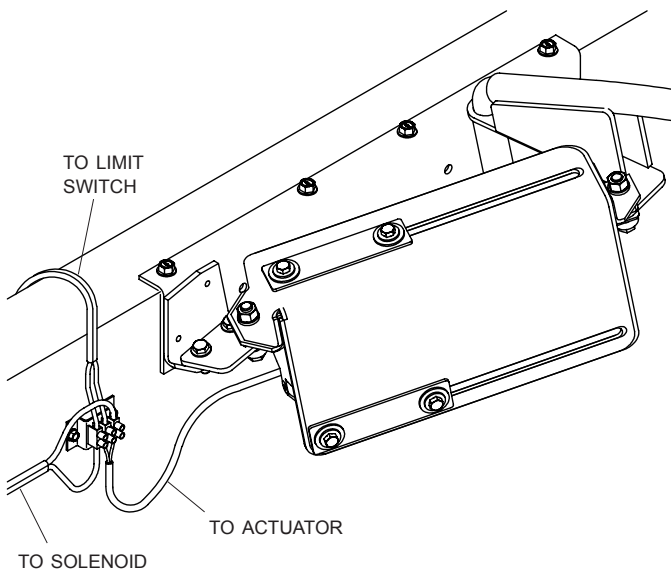

**NOTE:** Refer to trailer wiring pages for wiring procedures.

**NOTE:** A mounting bracket is included in your kit to assist mounting the terminal block to your trailer.

**STEP 24:** Align holes in terminal block with either pair of pre-punched holes in mounting bracket.

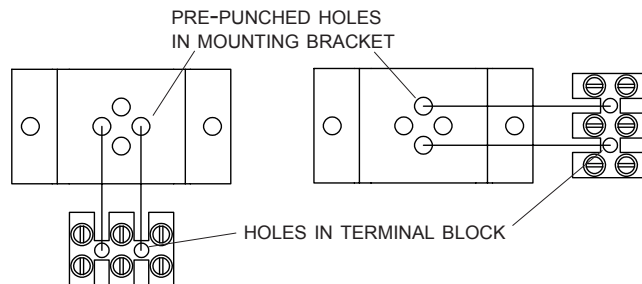

**STEP 25:** Fasten terminal block to bracket with two #6 x 7/8" screws and lock nuts.

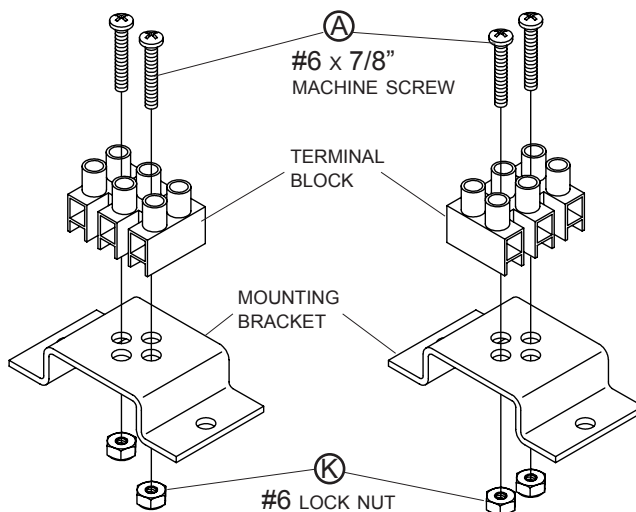

**STEP 26:** Using mounting bracket as a guide, mark and drill 3/16" holes in trailer and fasten terminal block/bracket assembly to trailer with #12 x 1" self-drilling screws.

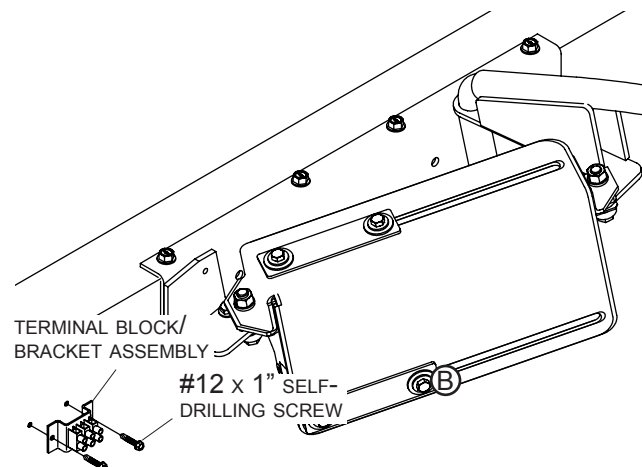

Item	Part #	Description
1.	1703661	Rocker Switch Mounting Bracket
2.	1116020	Rocker Switch
3.	1703845	Motor Reversing Solenoid
4.	1109015	Mounting Bracket
5.	1115385	Heavy-Duty Dual Conductor Plug
6.	1115386	Heavy-Duty Dual Conductor Socket
7.	1704126	25-Amp Auto-Reset Circuit Breaker
8.	1704573	Conductor Socket Sealed Boot
F.	1701045	Cap Screw - 5/16" x 3/4"
G.	1700400	Self-Tapping Screw - 3/8" x 1"
O.	1700411	Hex Nut - 5/16"
Q.	1700407	Hex Nut - 3/8"
W.	1700434	Lock Washer - 3/8"

Cut wires to length and strip only enough wire insulation to install ring terminals. Insert bare wire into ring terminals and crimp securely.

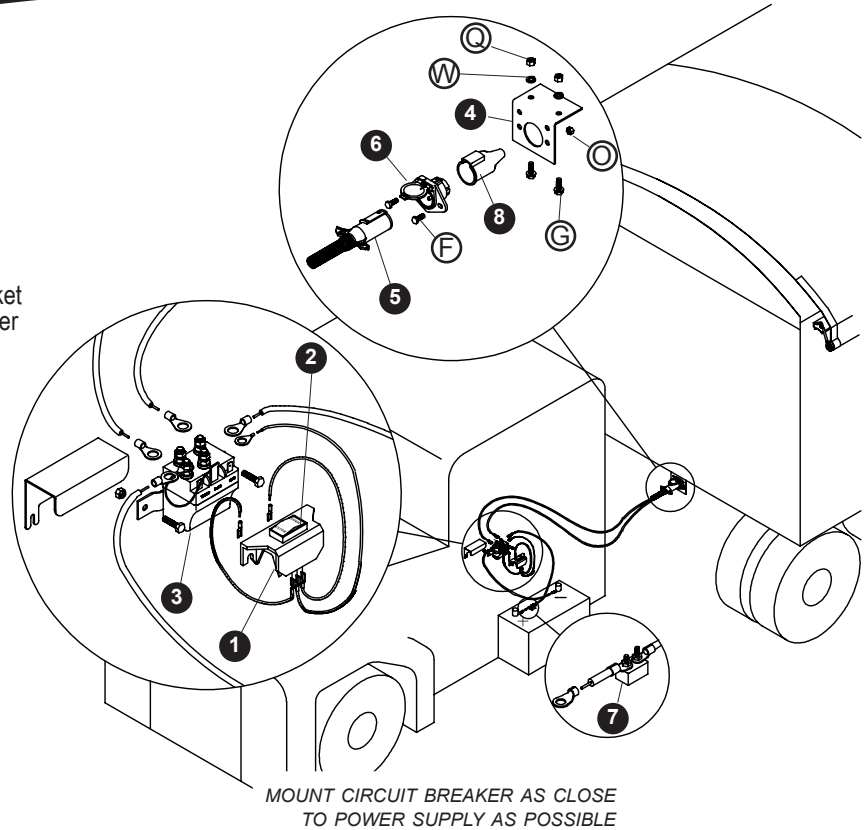
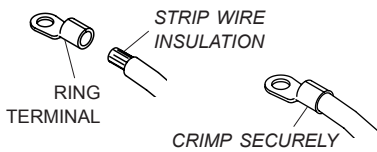

**STEP 1: Circuit Breaker & Battery:** Mount circuit breaker as close as possible to battery or power supply.

**STEP 2: Mount Solenoid:** Mount solenoid in a suitable location - a ventilated area near the battery is ideal. Determine best route for wire. This is usually along the frame with existing wire harness. Run 8 ga. wire from conductor plug to solenoid and from power supply to solenoid as shown in diagram. Run 14 ga. wires from solenoid to switch.

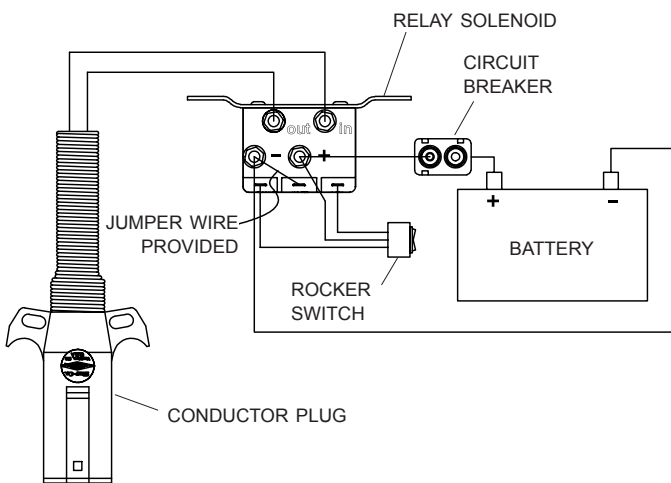

**STEP 3: Rocker Switch:** Locate rocker switch in a convenient operating location. Switch can be mounted in cab, on dash panel, on driver side door jamb or in a convenient location outside the cab.

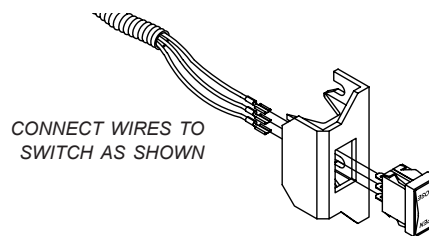

**STEP 4: Conductor Plug Option:** Unfasten and remove insert from conductor plug. Feed 8 ga. wire through plug and into brass contacts on insert. Tighten set screws to secure wires. Replace insert into conductor plug and secure screw.

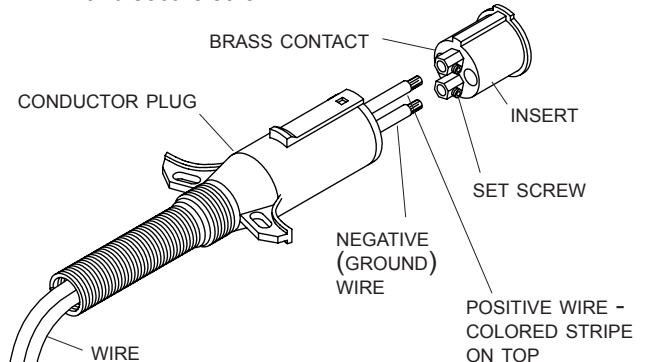

**Conductor Option for Trailers**

**STEP 1: Mounting Bracket:** Mount bracket at suitable location on front of trailer, usually near existing plugs. Mark and drill 5/16" holes and fasten with 3/8" x 1" self-tapping screws, lock washers and nuts.

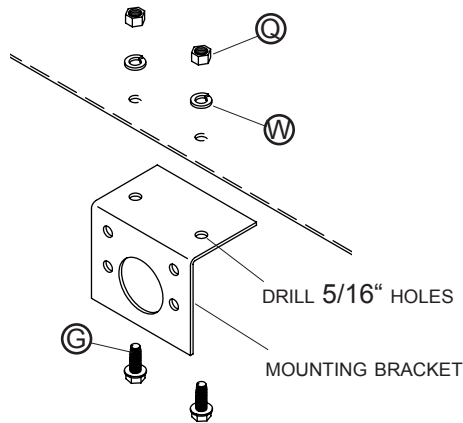

**STEP 2: Conductor Socket:** Fasten conductor socket to mounting bracket with screws (F) and nuts (O).

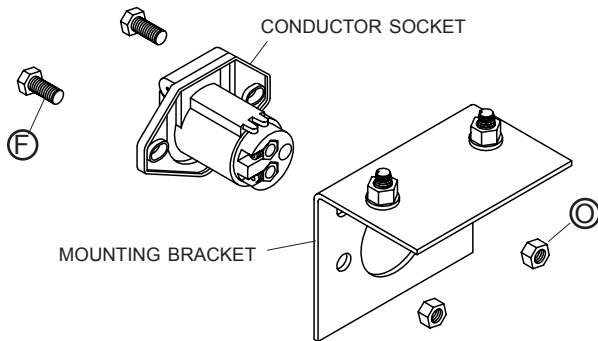

Bring 6 ga. wire from electric motor through sealed boot. Connect wire ends to conductor socket, aligning positive wire on socket with positive wire on conductor plug. Slide sealed boot against conductor socket and secure boot to wire with cable tie.

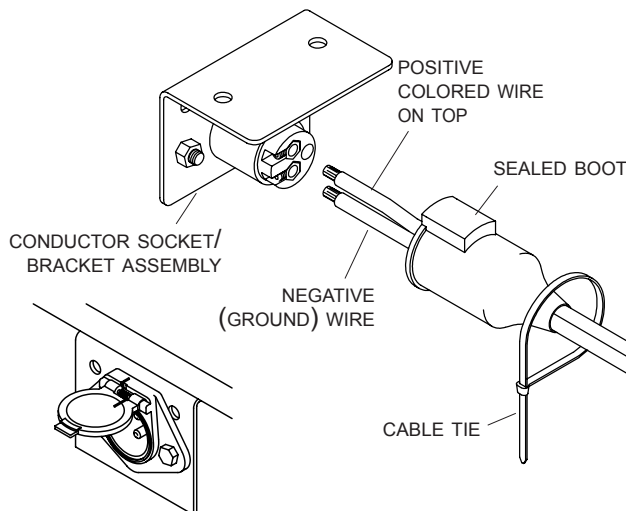

**STEP 3:** Connect wire from actuator, solenoid, and limit switch to terminal block. Apply dielectric grease to each connection before securing with terminal block screws.

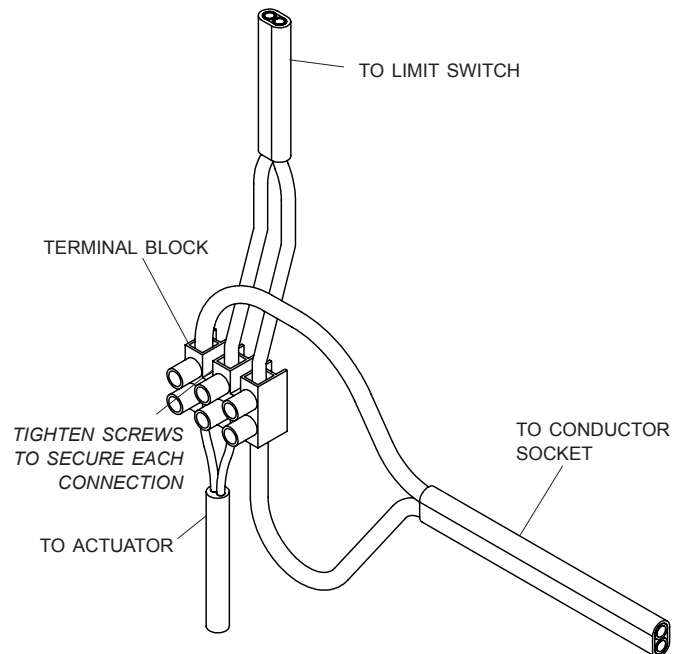

**NOTE:** If system is mounted on end dump-style box, run wire from front of box to box pivot and back to actuator at front of box. Do not place wire in areas where it can be pinched or cut during operation.

**Operation:**

**A) Check actuator direction** by activating switch to "OPEN." If switch is running system backwards, change wire leads on rocker switch or solenoid to opposite connections.

**B) Close Bows:** Push switch to "CLOSE" and hold. Observe bows and release switch when actuator clicks

**C) Open Bows:** Push switch to "OPEN" and hold. Observe bows and release switch when actuator clicks.

**NOTE:** Release switch at end of cycle or auto-reset circuit breaker will trip. After breaker resets, switch will activate actuator again. To reduce unnecessary strain on actuator, release switch at end of each cycle.

Item	Part #	Description
1.	1118257	Shur-Co® Wireless Receiver
2.	1109015	Mounting Bracket
3.	1115385	Heavy-Duty Dual Conductor Plug
4.	1115386	Heavy-Duty Dual Conductor Socket
5.	1704126	25-Amp Auto-Reset Circuit Breaker
6.	1704177	Ring Terminal - 8 Ga. 1/4" Stud
7.	1704573	Conductor Socket Sealed Boot
E.	1702926	Cap Screw - 5/16" x 7/8"
F.	1701045	Cap Screw- 5/16" x 3/4"
G.	1700400	Self-Tapping Screw - 3/8" x 1"
O.	1700411	Hex Nut - 5/16"
P.	1700419	Nylon Lock Nut - 5/16"
Q.	1700407	Hex Nut - 3/8"
V.	1201237	Flat Washer - 5/16"
W.	1700434	Lock Washer - 3/8"

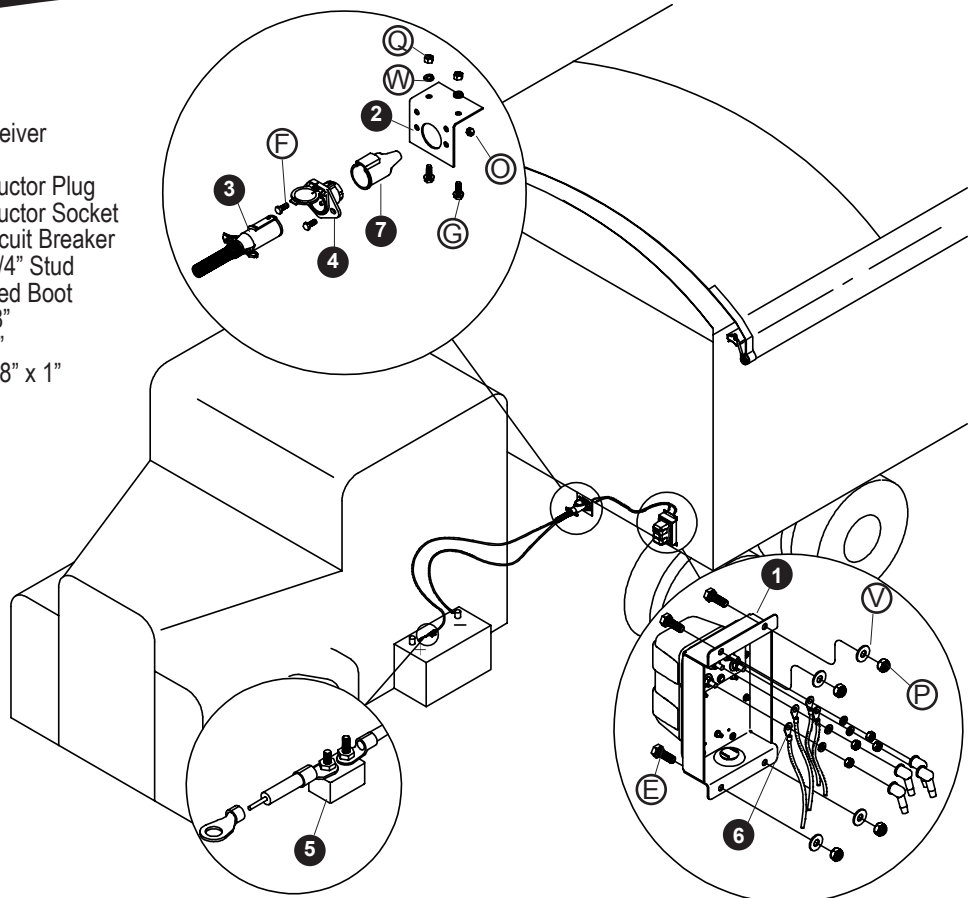

Cut wires to length and strip only enough wire insulation to install ring terminals. Insert bare wire into ring terminals and crimp securely.

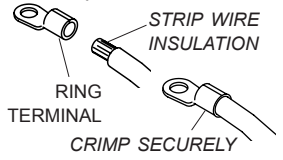

**STEP 1: Circuit Breaker & Battery:** Mount circuit breaker as close as possible to battery or power supply.

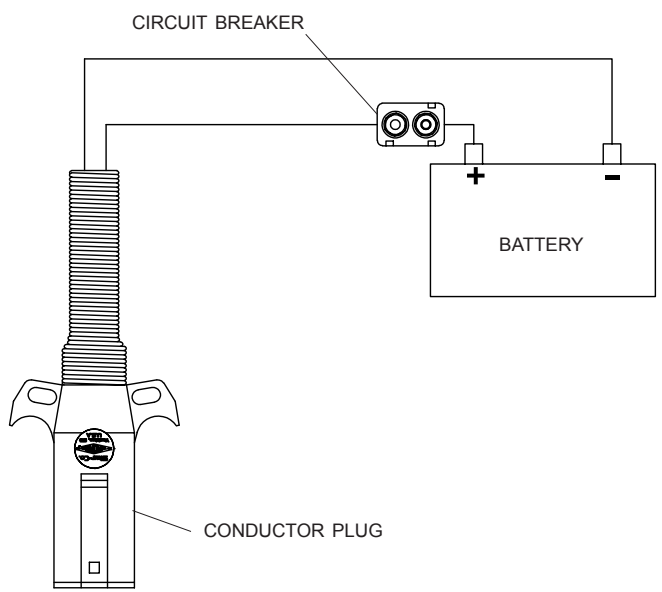

**STEP 2: Conductor Plug:** Unfasten and remove insert from conductor plug. Feed 8 ga. wire through plug and into brass contacts on insert. Tighten set screws to secure wires. Replace insert into conductor plug and secure screw.

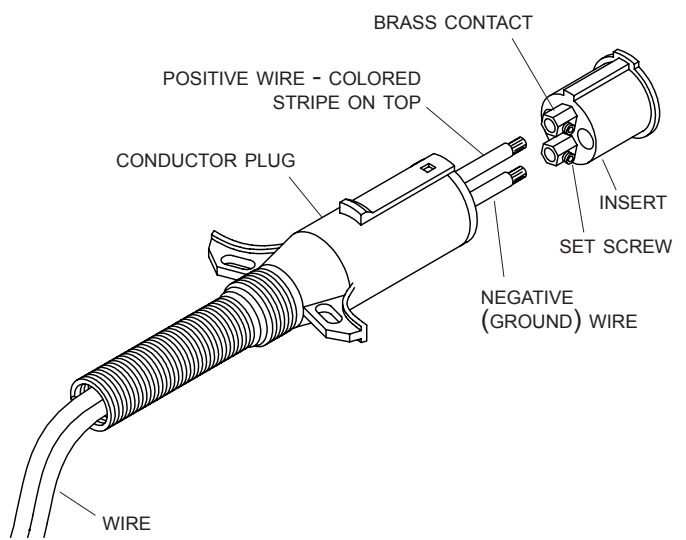

**Conductor Option for Trailers**

**STEP 1: Mounting Bracket:** Mount bracket at suitable location on front of trailer, usually near existing plugs. Mark and drill 5/16" holes and fasten with 3/8" x 1" self-tapping screws, lock washers and nuts.

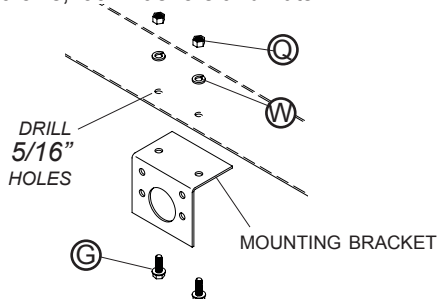

**STEP 2: Conductor Socket:** Fasten conductor socket to mounting bracket with screws **F** and nuts **O**.

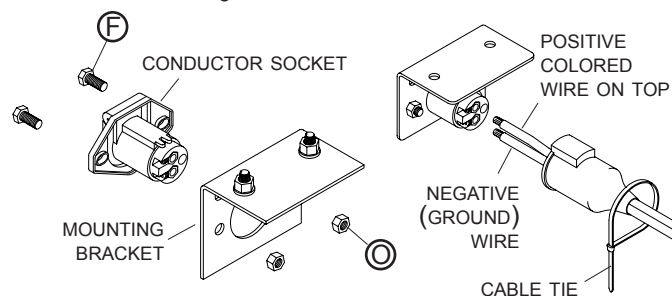

Bring 6 ga. wire from lower end of pivot arm through sealed boot. Connect wire ends to conductor socket, aligning positive wire on socket with positive wire on conductor plug. Slide sealed boot against conductor socket and secure boot to wire with cable tie.

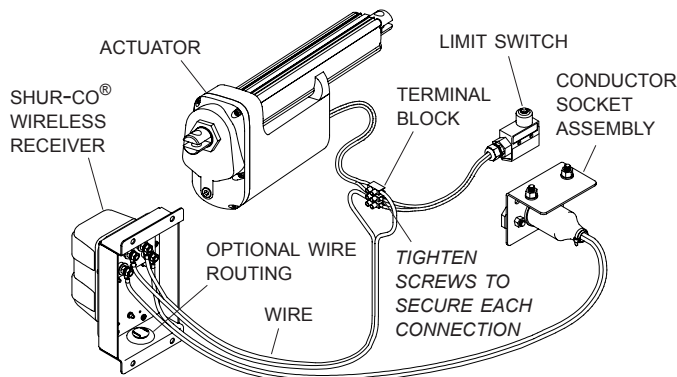

**STEP 3: Shur-Co® Wireless Receiver:** Route 8 ga. wire from terminal block to Shur-Co® Wireless Receiver. Route wire as desired. Insert end of this wire through rubber boots, then crimp 1/4" ring terminals onto wire ends. Remove nuts and lock washers from back of wireless receiver. Place positive wire on upper orange post and negative wire on upper black post. Secure lock washers and hex nuts. Coat with dielectric grease and install rubber boots over ring terminals.

USE DIELECTRIC GREASE (PART #1704378) TO PREVENT CORROSION ON TERMINALS.

Run a section of 8 ga. wire, long enough to reach the conductor socket, through rubber boots. Crimp 1/4" ring terminals to wire ends. On back of wireless receiver, place positive wire on lower orange post and negative wire on lower black post. Secure with 1/4" lock washers and hex nuts. Coat with dielectric grease and install rubber boots over ring terminals. When wiring conductor socket, align positive wire with positive wire on conductor plug.

Mount wireless receiver at suitable location on front of trailer. Mark and drill 11/32" holes and fasten with 5/16" x 7/8" cap screws, flat washers and lock nuts.

**STEP 4:** Connect wires from actuator, limit switch and wireless receiver to terminal block. Apply dielectric grease to each connection before securing with terminal block screws.

**NOTE:** If system is mounted on end dump-style box, run wire from front of box to box pivot and back to actuator at front of box. Do not place wire in areas where it can be pinched or cut during operation.

**⚠ CAUTION**

**Check all hardware for complete assembly before operating. Inspect system at this time and adjust as required.**

**Operation:**  
**A) Check actuator direction** by activating switch to "OPEN". If switch is running system backwards, change wire leads on rocker switch or solenoid to opposite connections.

**B) Close Bows:** Push switch to "CLOSE" and hold. Observe bows and release switch when actuator clicks.

**C) Open Bows:** Push switch to "OPEN" and hold. Observe tarp and release switch when actuator clicks.

**NOTE:** Release switch at end of cycle or modified-reset circuit breaker will trip. After breaker resets, switch will activate actuator again. To reduce unnecessary strain on actuator, release switch at end of each cycle.

**NOTE: Pressure Wash:** The receiver may be pressure washed, but keep nozzle at least 3' from system while spraying.

**Power-up/down:**

The transmitter will power up when the lid is opened. The transmitter will power down when the lid is closed or when the lid is left open three minutes after the last button is pushed.

**Standard Operation:**

After power-up, the first channel will be immediately active and the LED indicator for this channel will be flashing. The *Open/On* and *Close/Off* buttons are operational for the indicated active channel. While pressed, the LED indicator will flash faster, indicating channel operation.

The *Select* button will cycle between enabled channels. If only one channel is enabled, there will be no apparent change when the *Select* button is pressed.

**Channel Programming Mode:**

The Shur-Co® SMARTransmitter® has five channels. Pressing the *Select* button toggles through these channels. Unused channels can be disabled if desired, using the following process, but your transmitter is fully operational as shipped. This process may be skipped. Unused transmitter channels will not perform any functions.

Hold the *Select* button down for 10 seconds and the transmitter will enter *Channel Programming Mode*. Each time *Channel Programming Mode* is entered, the status of all five channels must be reset.

While in *Channel Programming Mode*, the programmable channel will be indicated by a solid lit LED.

**NOTE:** The transmitter will NOT activate any motor or lighting system while the transmitter is in *Channel Programming Mode*.

Press the *Open/On* button to enable the current channel (designated by the indicator light). Press the *Close/Off* button to disable the current channel. The indicator light will automatically jump to the next channel.

After programming all five channels, the transmitter will display the programmed channel status for all channels for three seconds. All enabled channel LEDs will be lit solid and all disabled channel LEDs will not be lit. Buttons will not function during this three-second period.

The transmitter will automatically exit *Channel Programming Mode* after three seconds and return to *Operational Mode*.

**NOTE:** If there is not at least one enabled channel after programming, the transmitter will not save the changes and will revert back to the previously saved channel settings.

**TIP:** To cancel your changes and exit *Channel Programming Mode*, close the transmitter cover.

**Channel Programming Example:**

The transmitter in this example is labeled with the following five channels:

- Tarp System 1
- Tarp System 2
- Bow System
- Auxiliary 1 \_\_\_\_\_
- Auxiliary 2 \_\_\_\_\_

These channel labels are for a standard construction transmitter. Your transmitter label may differ.

The task is to enable the *Tarp System 1*, *Tarp System 2* and *Bow System* channels.

1. Hold down the *Select* button for 10 seconds. The transmitter will enter *Learn Mode*. The *Tarp System 1* channel LED will be lit. All other channel LEDs are off.
2. Press the *Open/On* button to enable the *Tarp System 1* channel. The *Tarp system 2* LED will now be lit.
3. Press the *Open/On* button to enable the *Tarp System 2*. The *Bow System* LED will be lit.
4. Press the *Open/On* button to enable the *Bow System*. The *Auxiliary 1* channel LED will be lit.
5. Press the *Close/Off* button to disable the *Auxiliary 1* channel. The auxiliary LED will be lit.
6. Press the *Close/Off* button to disable the *Aux 2* channel LED.
7. The transmitter will display all activated channels for three seconds. The transmitter will automatically exit *Channel Programming* and revert to *Operational Mode*. The *Tarp System 1* LED will be flashing, indicating that the channel is active and ready for operation.

**Transmitter to Receiver Programming:**

Shur-Co® SMARTransmitter® wireless systems are typically pre-programmed at the factory or by the dealer and should be ready to use as shipped. Re-programming is necessary after replacement transmitters or receivers are installed.

Use the following method to program the RF receiver to accept and respond to signals from up to five transmitters. The receiver will not accept or respond to signals from transmitters that have not been programmed using this method.

1. Remove the receiver cover, pulling gently on the cover to prevent damage to wires that are connected to the rocker switch.
2. Check to be sure the receiver is connected to the power supply. The receiver must be connected to power to be programmed. If a battery disconnect switch is installed, make sure it is turned on.
3. The receiver can learn to recognize and respond to up to five transmitters. Gather all of the transmitters to be introduced to the receiver. Open the transmitter lid(s) in order to turn them on.
4. Set the transmitter(s) to the appropriate channel (*Bow System*, etc.). See *Transmitter Operation & Programming Instructions*.

**NOTE:** Read the following steps in their entirety before proceeding. Steps 6 to 8 must be completed within 10 seconds.

5. Press and hold the programming button on the bottom of the RF solenoid for five seconds. The solenoid will beep to indicate that it is in programming mode. Release the programming button.
6. Press the *Open/On* button on the first transmitter being introduced. The receiver will beep after receiving the transmitter signal.
7. Repeat step 6 for any remaining transmitters.
8. The receiver will expect five signals, so if you are programming less than five transmitters, press the *Open/On* button additional times on the last transmitter you are programming. Push the *Open/On* button a total of five times (see programming example).
9. After pushing the *Open/On* button five times, the receiver will beep twice to indicate that it has been programmed successfully.

**NOTE:** The receiver will exit program mode after 10 seconds, whether or not it has five *Open/On* button signals.

10. Verify that each transmitter is operating correctly. If none of the transmitters are operating correctly, verify that there are 12 to 14 volts from the receiver positive to negative, then repeat steps 3 to 9.

11. Refasten receiver cover.

**Receiver Programming Example:**

In this example, the receiver controls the actuator. The task is to program the receiver to recognize three transmitters.

1. Remove the receiver cover and turn on the three transmitters.
2. Set all three transmitters to the bow system channel.
3. Press and hold the programming button on the RF solenoid for five seconds. The solenoid will beep to indicate it has entered *Channel Programming Mode*. Release the programming button.
4. Press the *Open/On* button on the first transmitter. The receiver will beep to indicate that it has received a signal and memory slot #1 has been filled.
5. Press the *Open/On* button on the second transmitter. The receiver will beep to indicate that it has received a signal and memory slot #2 has been filled.
6. Press the *Open/On* button on the third transmitter. The receiver will beep to indicate that it has received a signal and memory slot #3 has been filled.
7. Press the *Open/On* button on the third transmitter again. The receiver will beep to indicate that it has received a signal and memory slot #4 has been filled.
8. Press the *Open/On* button on the third transmitter again. The receiver will beep twice to indicate that it has received a signal and memory slot #5 has been filled. The double beep also indicates that the receiver has exited programming mode.
9. Verify that the bow system *Open* and *Close* operations are functioning correctly on all three transmitters.
10. Refasten the receiver cover to motor assembly.

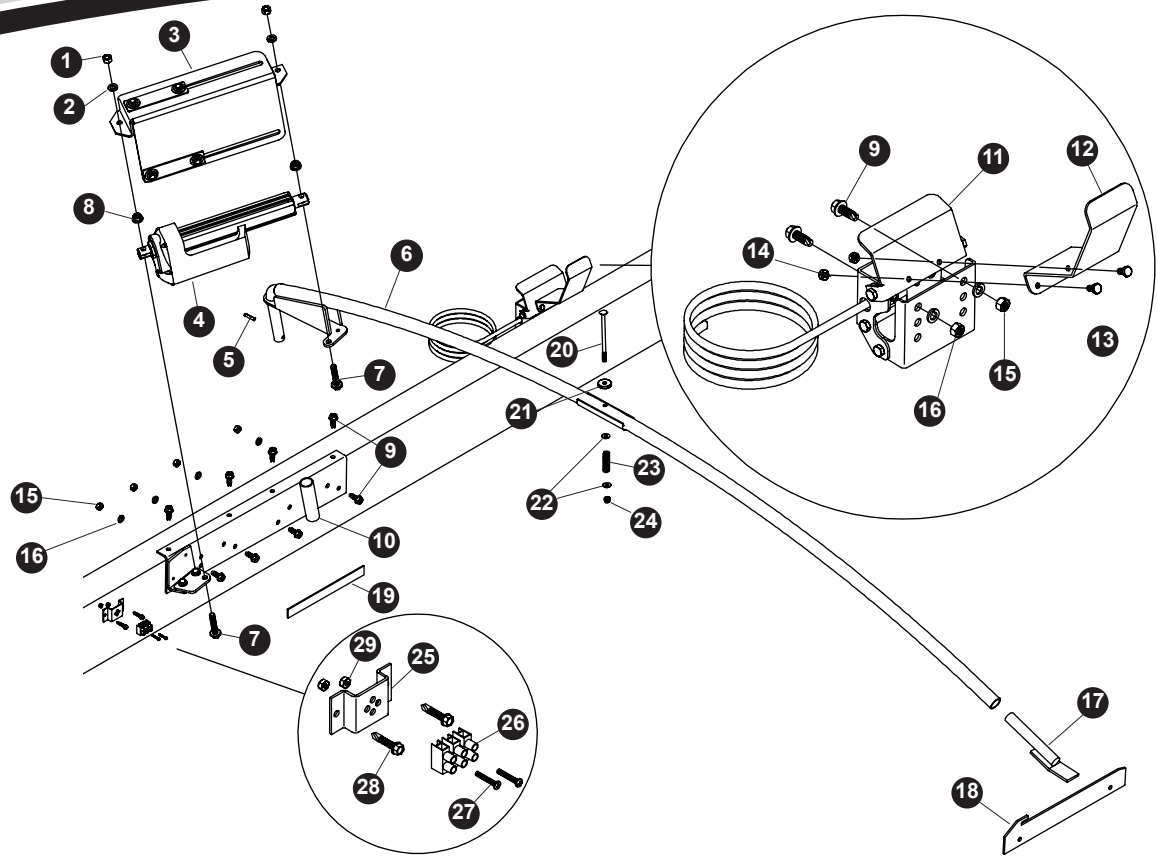

Item	Part #	Description	Item	Part #	Description	Item	Part #	Description
1.	1704181	Full Hex Nut - M12 x 1 3/4"	10.	1117628	Bow Pivot Bracket	19.	1107006	Pivot Bracket Spacer
2.	1700437	Lock Washer - 1/2"	11.	1117637	Limit Switch	20.	1701216	Carriage Bolt - 5/16" x 5 1/2"
3.	1117633	Actuator Shield	12.	1117643	Contact Bracket Offset Adapter	21.	1701215	Washer - 1/4" x 1 1/4" x 5/16"
4.	1704130	Electric Linear Actuator - 8" Stroke	13.	1703960	Cap Screw - 1/4" x 1/2"	22.	1700427	Flat Washer - 1/4"
5.	1701118	Spring Pin - 1/4" x 1 3/16"	14.	1704185	Thin Nylon Lock Nut - 1/4"	23.	1701217	Compression Spring - .6" x .072" x 2"
6.	1117623	Low Rise Bow	15.	1700407	Hex Nut - 3/8"	24.	1700419	Nylon Lock Nut - 5/16"
	1117622	High Rise Bow	16.	1700434	Lock Washer - 3/8"	25.	1117647	Terminal Block Mounting Bracket
7.	1704179	Flange Cap Screw - M12 x 60	17.	1105333	Low Rise Bow Rest	26.	1704190	Terminal Block - 3 Circuit - Euro
8.	1704180	Flange Lock Nut - M12 x 1 3/4"		1105327	High Rise Bow Rest	27.	1704191	Pan Hd. Machine Screw - #6 x 7/8"
9.	1700400	Self-Tapping Screw - 3/8" x 1"	18.	1105314	Bow Stop	28.	1701471	Self-Drilling Screw - #12 x 1"
						29.	1704184	Nylon Lock Nut - #6

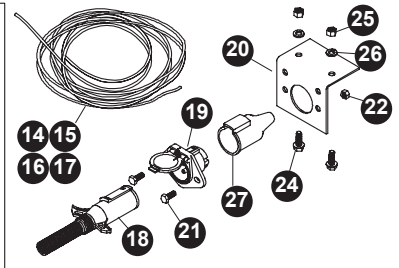
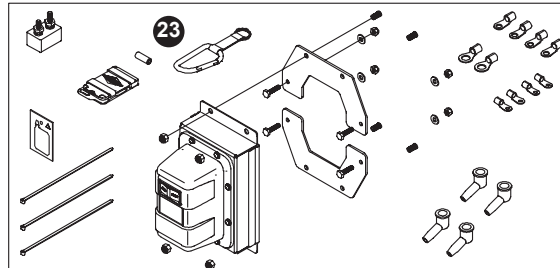
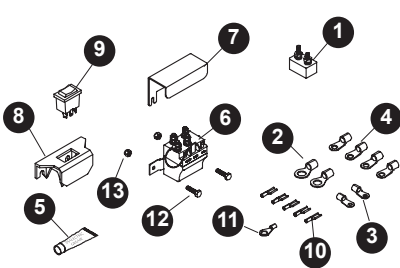

Item	Part #	Description	Item	Part #	Description	Item	Part #	Description
	1109016	Dual Conductor w/Hardware	8.	1703661	Rocker Switch Mounting Bracket	18.	1115385	Heavy-Duty Conductor Plug
	1117642	Electric Parts Kit	9.	1116020	Rocker Switch	19.	1115386	Heavy-Duty Conductor Socket
	1110368	Bow Attach Spring Assembly	10.	1703659	Push-On Terminal - 14 Ga. 1/4"	20.	1109015	Dual Conductor Mtg. Bracket
	1117641	Rocker Switch Electrical Parts Kit	11.	1704153	Ring Terminal - 16 to 14 Ga. 1/4" Stud	21.	1701045	Cap Screw - 5/16" x 3/4"
1.	1704126	25-Amp Auto-Reset Circuit Breaker	12.	1700381	Cap Screw - 1/4" x 1"	22.	1700411	Hex Nut - 5/16"
2.	1704174	Ring Terminal - 8 Ga. 3/8" Stud	13.	1701543	Nylon Lock Nut - 1/4"	23.	1118434	Shur-Co® Wireless Receiver w/Adapter
3.	1704175	Ring Terminal - 8 Ga. #10 Stud	14.	1117651	Electrical Wire - 8 Ga. 2 Cond. 100'	24.	1700400	Self-Tapping Screw - 3/8" x 1"
4.	1704177	Ring Terminal - 8 Ga. 1/4" Stud	15.	1117652	Electrical Wire - 8 Ga. 2 Cond. 75'	25.	1700407	Hex Nut - 3/8"
5.	1704192	Dielectric Grease - 1/3 Oz. Tube	16.	1117653	Electrical Wire - 8 Ga. 2 Cond. 50'	26.	1700434	Lock Washer - 3/8"
6.	1703845	Motor Reversing Solenoid	17.	1117654	Electrical Wire - 8 Ga. 2 Cond. 30'	27.	1704573	Conductor Socket Sealed Boot
7.	1703896	Solenoid Cover						

Our **Advanced Troubleshooting Guide** is available on our website:  
<http://www.shurco.com>, or call our Help Line: **1-866-748-7435**.

Problem:	Try This:
<p>The SMARTransmitter® is not working.</p> <p>None of the lights on the remote turn on when I open the lid.</p>	<ol style="list-style-type: none"> <li>1. Make sure the battery is placed correctly.</li> <li>2. The battery may be dead and must be replaced. Replacement high-capacity SMARTransmitter® batteries may be purchased from Shur-Co® (part #1704573).</li> <li>3. The SMARTransmitter® may be damaged. Call Shur-Co's Help Line.</li> </ol>
<p>The SMARTransmitter® is not working.</p> <p>I can operate the system with the rocker switch but not with the remote. The SMARTransmitter® channel light (Bow System, for example) is blinking, and when I press the Open/On button, the light blinks faster.</p>	<ol style="list-style-type: none"> <li>1. Make sure the remote is set to the right channel. If you cannot set the remote to the desired channel (Bow System for example), the remote must be reprogrammed. See the SMARTransmitter® programming instructions.</li> <li>2. Make sure you are within a couple feet of the receiver and try again.                         <ol style="list-style-type: none"> <li>a) If it works at short range but not at greater distances, you have a range problem. A new battery may be needed. If the remote battery is not the cause, call Shur-Co's Help Line.</li> </ol> </li> <li>3. Reprogram the receiver. See the receiver programming instructions. If this doesn't work, call Shur-Co's Help Line.</li> </ol>
<p>The system will not operate with the rocker switch or with the SMARTransmitter®.</p> <p>When I try to use the rocker switch or SMARTransmitter®, I don't hear any noises (a clicking noise, for example) from the receiver.</p>	<ol style="list-style-type: none"> <li>1. Make sure the master disconnect switch is turned to the "ON" position.</li> <li>2. The circuit breaker may have tripped. Wait one minute and try again.</li> <li>3. Check the vehicle's battery to make sure it isn't dead.</li> <li>4. Check all connections from the battery to the system. Check for polarity, good connections and corrosion. Verify that you have at least 12V on the back side of the receiver on the battery hookup posts.</li> <li>5. Call Shur-Co's Help Line.</li> </ol>
<p>The system will not operate with the rocker switch or with the SMARTransmitter®.</p> <p>When I try to use the rocker switch or SMARTransmitter®, I hear a clicking noise but nothing happens.</p>	<ol style="list-style-type: none"> <li>1. Verify that you have at least 12V on the back side of the receiver on the battery hookup posts.</li> <li>2. Call Shur-Co's Help Line.</li> </ol>
<p>The rocker switch is not sticking, but the motor continues to run after I release the rocker switch.</p>	<ol style="list-style-type: none"> <li>1. Call Shur-Co's Help Line.</li> </ol>
<p>The rocker switch is sticking.</p>	<ol style="list-style-type: none"> <li>1. Check the switch for excessive dirt, rocks or other objects. If the rocker switch cannot be cleaned, call Shur-Co's Help Line for a replacement receiver.</li> </ol> <p><b>Pressure Wash:</b> The receiver may be pressure washed, but keep nozzle at least three feet from system while spraying.</p>

Our **Advanced Troubleshooting Guide** is available on our website:  
<http://www.shurco.com>, or call our Help Line: **1-866-748-7435**.

## MORE QUALITY PRODUCTS FROM SHUR-CO®

---

- Value Series Shur-Lok®
- Super Duty Shur-Lok®
- Value Series Belt & Ratchet
- Premium Belt & Ratchet
- Shur-Lok® Junior
- Cable-Lok™ Spool Tarp
- 3500 Series Electric Shur-Lok®
- Value Series Electric Shur-Lok®
- Super Duty Electric Shur-Lok®
- SMARTrailer™ Accessories
- SMARTransmitter®
- ProTrap® Electric Hopper Door Opener
- Electric Turning Point™ Bow System
- Shur-Trak II™ Cable System
- Cover-Pro II® Cable System
- UltraSteel Arm System
- Arm-Matic™ Arm System
- Fitted & Flat Covers
- Turning Point™ Bow System
- Combine Hopper Ext. Covers
- Stock & Custom Flatbed Tarps
- Load Control Line
- Genuine Replacement Tarps
- Genuine Replacement Parts
- Solar Power Pack

ENGINEERED TARPING SOLUTIONS

